



# DeLuxe STITCHER

COMPANY INC.

solving your wire stitching needs for 125 years...

## ISP Stitching & Bindery Products

# OWNERS MANUAL

# M2000 High Performance Stitcher Head with One Touch Technology

FEATURING STITCHING HEADS

**CTTT2606P**

**CTTT2606W**

**CAAA2006W**

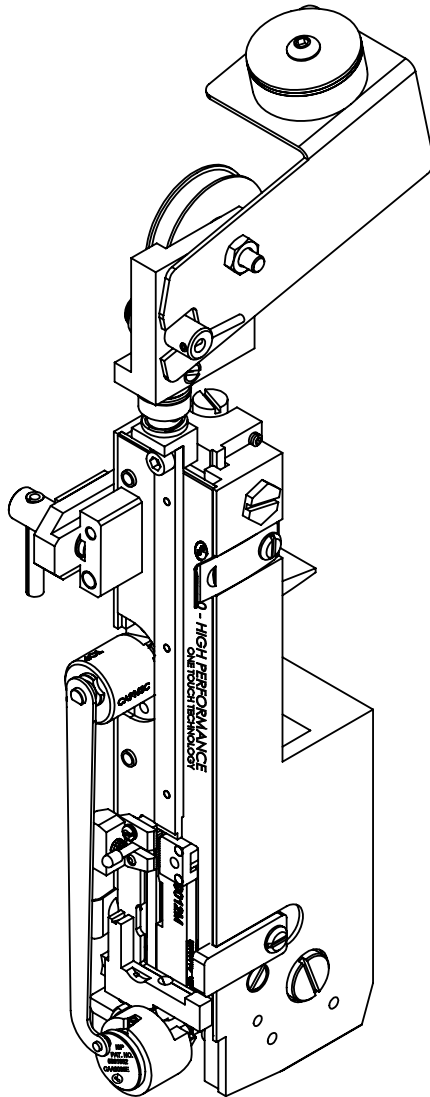

**CAAA2006W**

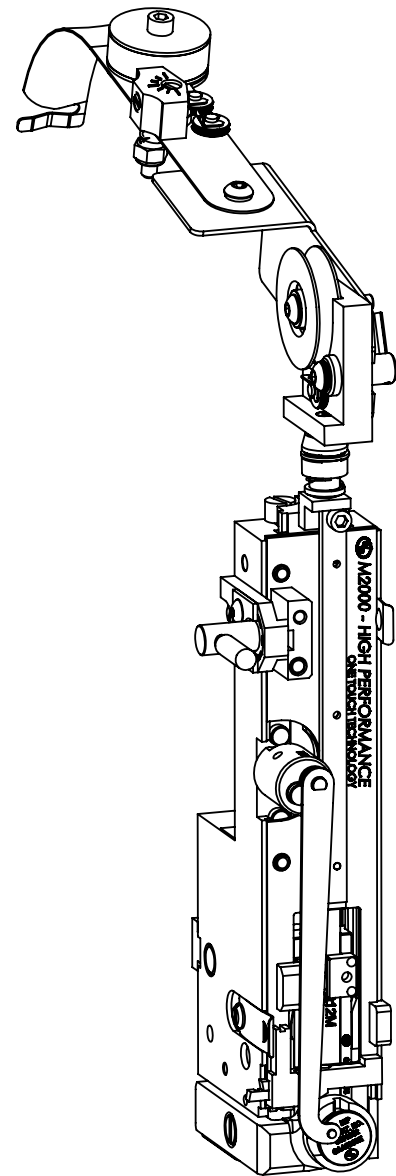

**CTTT2606W**

**CTTT2606P**

# **HIGH PERFORMANCE**

## **CONTENTS**

<b>Safety</b> .....	<b>3</b>
<b>Specifications</b> .....	<b>4</b>
<b>Dimensions</b> .....	<b>5</b>
<b>Lubrication</b> .....	<b>6</b>
<b>Threading</b> .....	<b>7</b>
<b>Mounting Options</b> .....	<b>8</b>
<b>Trouble Shooting</b> .....	<b>10</b>
<b>Adjustments</b> .....	<b>13</b>
<b>Parts: Stitching Head</b> .....	<b>14</b>

## **SAFETY**

### **SAFETY PRECAUTIONS AND PROCEDURES**

1. *Make sure electrical power is turned off before performing any adjustment or maintenance.*
2. *Keep hands, hair, tools, and clothing clear of stitching area.*
3. *Become familiar with the moving components of your machine. Keep fingers away from areas that could pinch or cut.*
4. *A well maintained machine is a safer machine. Clean and lubricate the machine at regular intervals. Check machine daily for broken or worn parts. Replace as necessary. DO NOT attempt to operate the machine if a part is broken.*
5. *If you are unsure how to safely operate your stitching head, contact your Service Representative.*



**DANGER**

**KEEP HANDS CLEAR OF STITCHING AREA!**



**CAUTION**

Be sure your stitcher or collator has adequate guards to keep fingers out of the **HIGH PERFORMANCE'S** point of operation.

**Specifications**

**Weight**

Shipping Weight ..... 7 lbs (3.2 kg)

**Physical Dimensions**

Height without Spring ..... 10-3/4" (26.3 cm)

Width ..... 2" (5.1 cm)

Box Size ..... 16" x 8" x 3" (41cm x 20cm x 8cm)

**Stitching Capacity** ..... Two Sheets to 1/8" (3 mm)

**Wire Types** ..... 22 through 28 round or 21 x 25 or 23 flat  
**25 Ga. (0.50 mm) STANDARD**

**Crown Sizes** ..... 1/2" (12.7mm)  
Other Size Available

**Minimum Head Centers** ..... 1-7/8" (47.6mm)

**Stitches Per Hour** ..... 12,000

# Dimensions

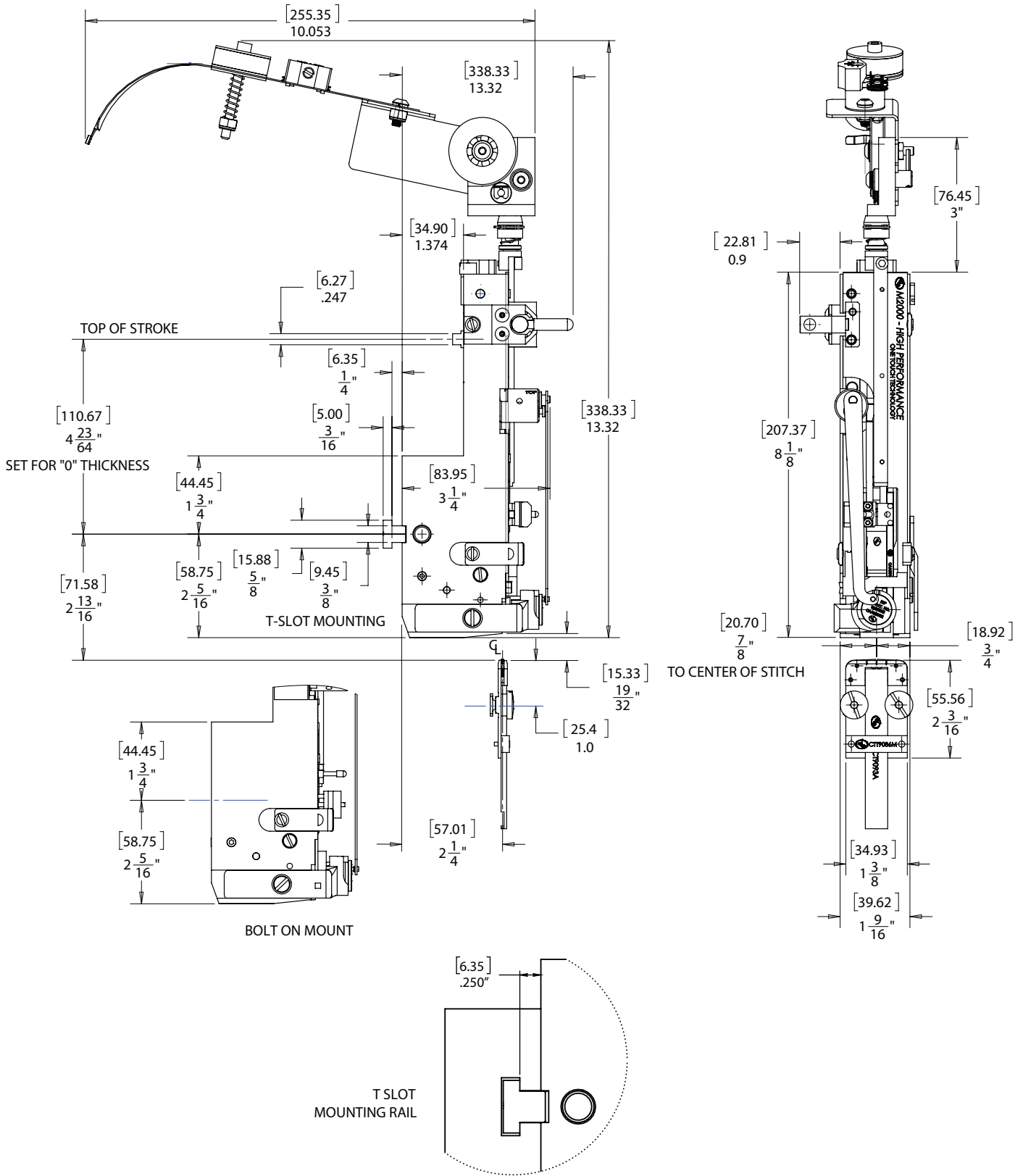

# HIGH PERFORMANCE

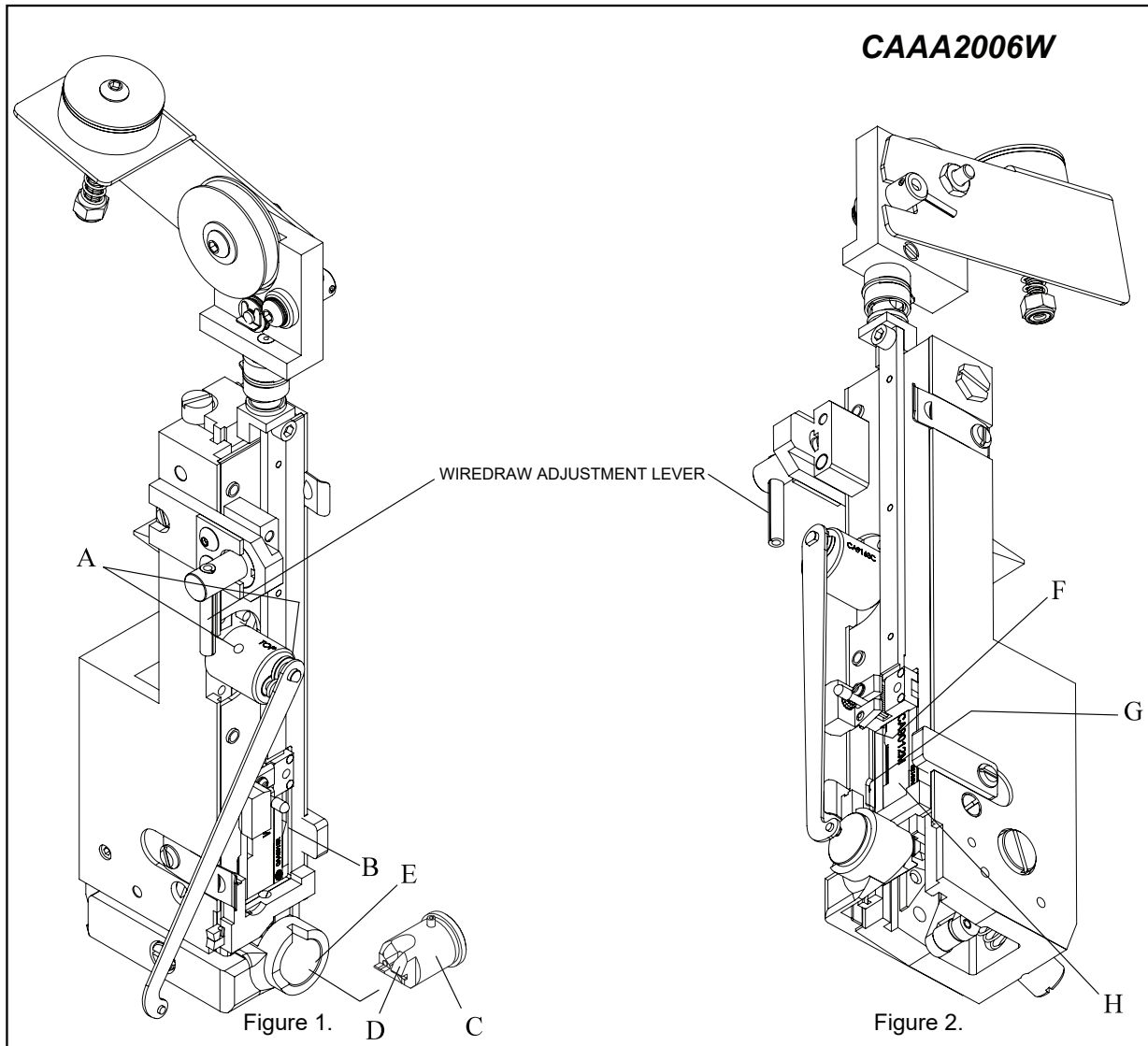

## STITCHING HEAD LUBRICATION

Typically, the 1/2 inch crown stitcher will run for 1,000,000 cycles without additional lubrication. However, the following procedure used after each spool of wire will assure optimum life and performance. Use standard SAE10 lubricant

- A. Inject lube into hole, or remove and lube shafts.
- B. Wipe area clean and inject a small amount of lube into cam area.
- C. Remove rotator, wipe rotator clean and lube rotator body.
- D. Apply lube to rotator ramp.

- E. Wipe clean inside of rotator holder.
- F. Inject a small amount of lube into cam area of driver bar.
- G. Inject lube into cutter operating slide.
- H. Wipe driver clean, and apply a light coating of lube.

After prolonged use (or storage) accumulations of wire dust, dirt, or other contaminants can mix with the stitcher lubricant. This will reduce the lubricant's effectiveness. The following procedure is recommended every 1,000,000 cycles.

1. Disassemble the head and clean all parts.
2. Lightly lube all sliding surfaces using standard SAE10 lubricant.
3. Double check lube points A through H.

1. After every wire spool, rotate the dirty area of the pads slightly so that a clean area can be used for the next wire spool.

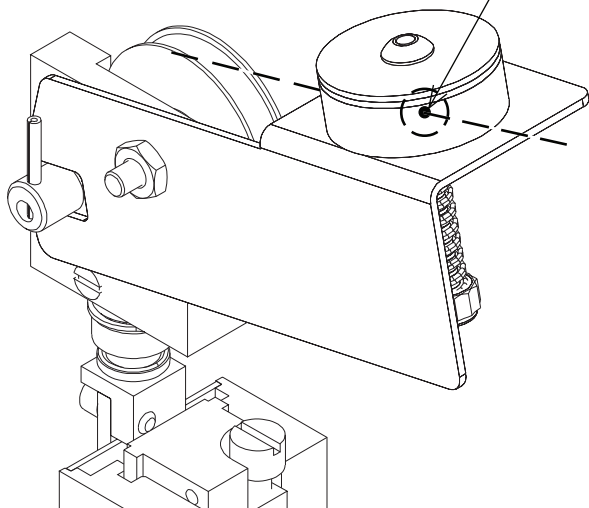

2. Dampen both pads (about 30 to 40 drops) using an SAE 20W oil.

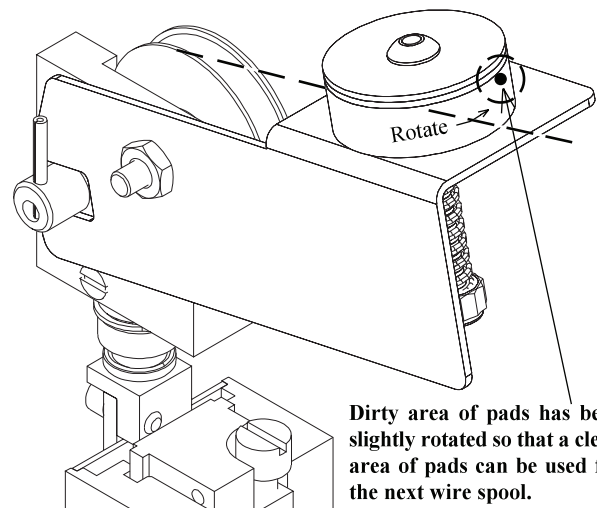

Figure 3.

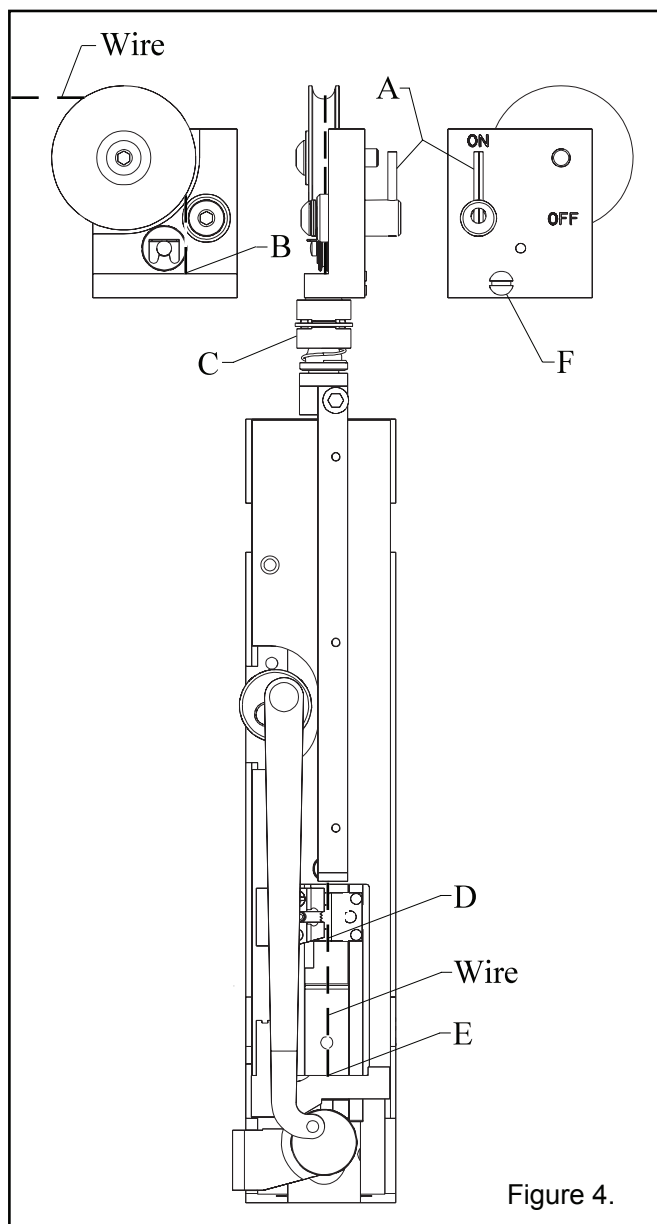

Figure 4.

**IMPORTANT!** In order for the stitchers to operate properly, the felt wire wipes **MUST** be rotated and dampened with SAE 20W oil before each new spool of wire (50,000 to 70,000 stitches). Replace felt pads when they become so dirty that they cannot be rotated to a clean spot.

### THREADING

1. Rotate the wire threading lever (A) clockwise to the "OFF" position.
2. Feed the wire over the top roller, between the straightening rollers, and into the hole in the bracket as indicated (B).
3. Push downward on check pawl collar (C) to continue to feed the wire. The collar can be released when the wire gets past the check pawl.
4. Continue to feed the wire, and watch for it to come out past the gripper (D).
5. Feed a little more wire, and guide it into the hole in the top of the cutter (E). Allow the wire to enter this hole about 1/8".
6. Turn wire threading lever (A) counter clockwise to the "ON" position.
7. If necessary, tighten set screw (F) to keep the top roller aligned with the spool of wire.
8. Install wire between thin and thick round felt pads.

The head is now ready to operate. Please note that two cycles of the newly threaded head will be required before you get a proper stitch.

# **HIGH PERFORMANCE**

## **MOUNTING OPTIONS**

### **BOLT MOUNT CAAA2006W**

The bolt mounted stitching option is an easy and effective method in mounting your M2000 High Performance stitcher heads.

Mounting the head begins with locating the Drive Lug (A) that is part of the Driving Slide Assembly with the Head Actuating Bar (B) in the slot and aligning the 1/2" tapped bolt hole (C) with the Head Support Bar at (D) inside the B3000 Bookletmaker as shown in Figure 5.

Once the head is properly aligned in your machine, a clamping knob (E) is inserted through a series of washers and into the head support bar/bonnet interface and tightened where it properly secures the stitching head in place.

The stitching heads are conveniently adjustable by way of the slot and hole patterns on the actuating and supporting bars to accommodate a variety of applications.

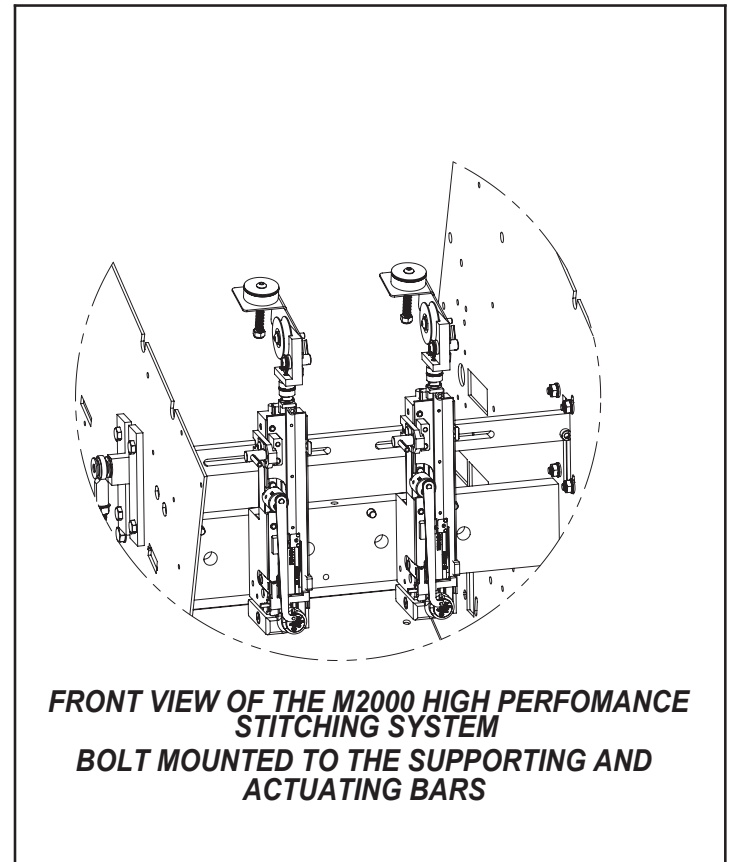
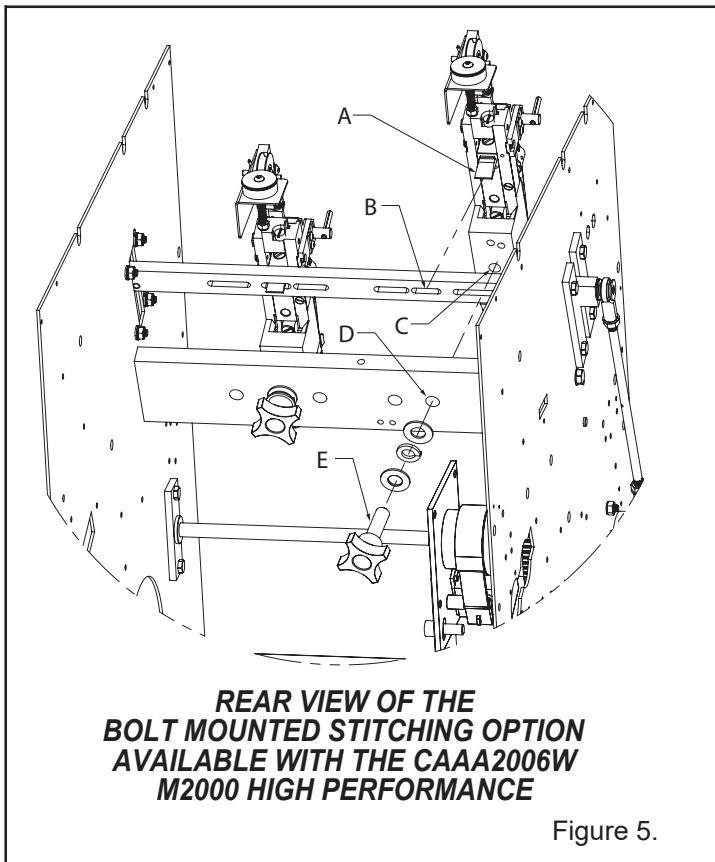



# HIGH PERFORMANCE

## MOUNTING OPTIONS

### CLAMP MOUNT CTTT2606W

The clamp mounted stitching option is also an easy and effective method in mounting your M2000 High Performance stitcher heads.

Mounting the head begins with locating the Bonnet Clamp Block (A) in the slot that is part of the machine rail system (B) and aligning the mounting hole (C) in back of the bonnet with the Bonnet Clamp Block back at (A).

Once the head is properly aligned in your machine, the Bonnet Clamping Handle (D) is inserted through a clamping hole (E) on the side of the bonnet and rotated to properly secure the stitching head in place.

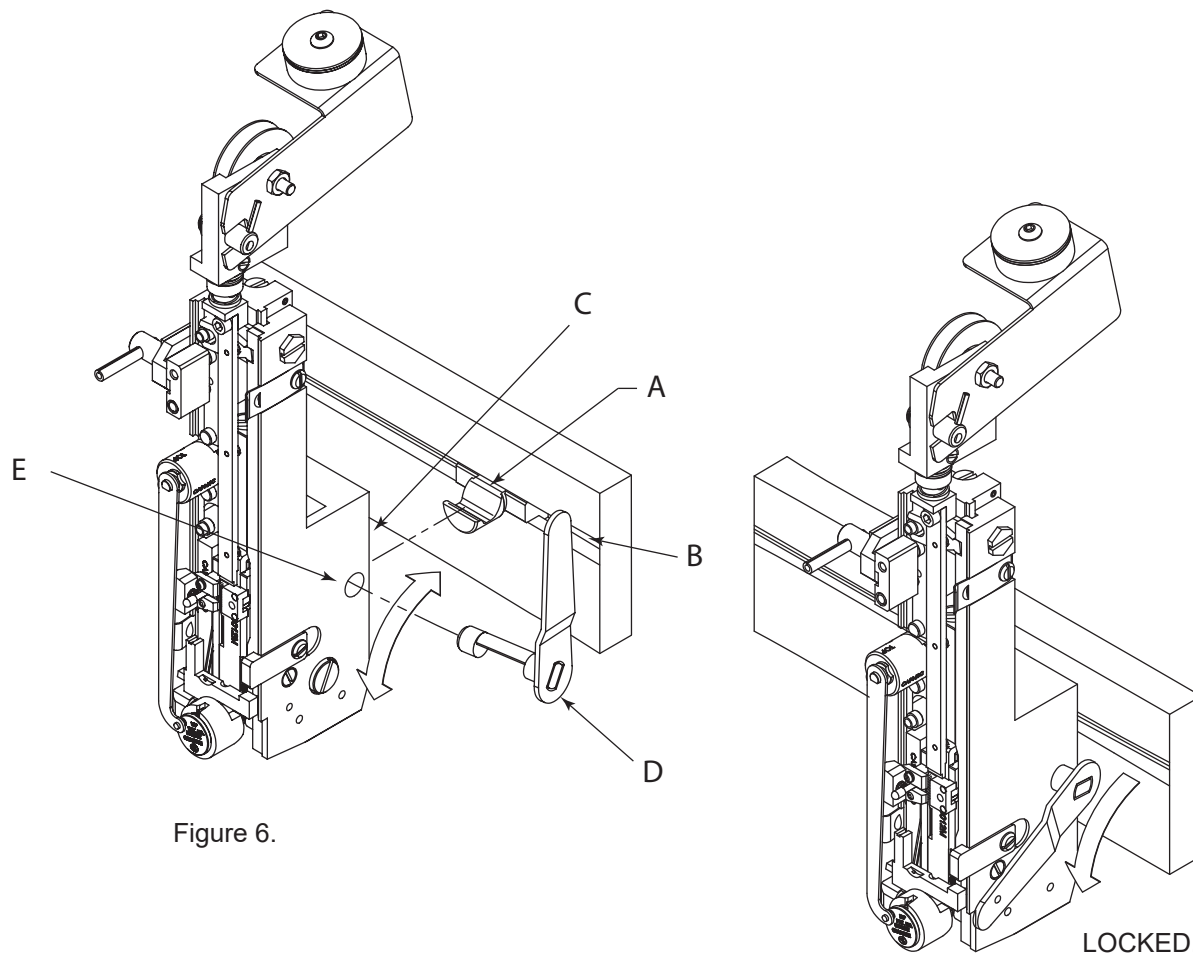

Figure 6.





# HIGH PERFORMANCE





## TROUBLE SHOOTING



HERE'S HOW A PERFECT STITCH LOOKS.

One or more mechanical problems can cause malformed stitches. Use the following chart to resolve any problems. Be sure to check each possible cause.

TROUBLE	POSSIBLE CAUSE & REMEDY
<p>3. One or both legs are buckled.</p>  <p>NOTE: Since buckled legs are often concealed in the work and may appear the same as a short leg, always remove two or more stitches to see which condition is occurring.</p>  <p>4. Crown is wrinkled.</p>	<ol style="list-style-type: none"> <li>1. Clincher is improperly aligned with head. Adjust clincher or head sideways. On a Stitch'n Fold, loosen the mounting knob behind the head, tilt the head slightly to one side, and tighten.</li> <li>2. Clincher is worn. Replace clincher.</li> <li>3. Insufficient compression. Adjust clincher upward or set head actuating bar lower.</li> <li>4. Unequal leg length. Balance stitch legs per instructions on page 10.</li> <li>5. Wire is wrong size. Use only approved stitching wire: part number 25G5</li> <li>6. Bender bar is worn. Replace bender bar, item 46 on page 15. (Or replace bender bar assembly, item 45 on page 15)</li> </ol>
<p>5. Stitch crown is not flat.</p> 	<ol style="list-style-type: none"> <li>1. Insufficient compression. Adjust clincher upward or set head actuating bar lower.</li> </ol>
<p>6. Leg length varies.</p> 	<ol style="list-style-type: none"> <li>1. Unequal leg length. Balance stitch legs per instructions on page 10.</li> <li>2. Grip is worn or dirty. Clean or replace grip, item 55 on page 15.</li> <li>3. Grip spring is weak or broken. Replace grip spring, item 59 on page 15.</li> <li>4. Grip release slide is worn. Replace grip release slide, item 23 on page 14.</li> <li>5. Driver bar is worn. Replace driver bar, item 47 on page 15.</li> <li>6. Check pawl is worn or dirty. Clean check pawl assembly, item 37 on page 14. Replace worn check pins, or replace check pawl assembly.</li> <li>7. Excessive tension on wire straightener. Turn roll pin, item A on page 7 toward the off mark.</li> </ol>
<p>7. One or both legs turn out.</p> 	<ol style="list-style-type: none"> <li>1. Clincher is improperly aligned with head. Adjust clincher or head sideways. On a Stitch Fold, loosen the mounting knob behind the head, tilt the head slightly to one side, and tighten.</li> <li>2. Wire cutters are dull. Replace wire cutters, item 22 on page 14.</li> </ol>

TROUBLE	POSSIBLE CAUSE & REMEDY
<p>8. Corner of crown is distorted or fractured.</p> 	<ol style="list-style-type: none"> <li>1. Driver bar end is broken. Replace driver bar, item 47 on page 15.</li> <li>2. Bender bar is worn. Replace bender bar, item 46 on page 15. (Or replace bender bar assembly, item 45 on page 15.)</li> <li>3. Wire is wrong size or poor quality. Use only approved stitching wire: part number 25G5</li> <li>4. Clincher is improperly aligned with head. Adjust clincher or head sideways. On a Stitch Fold, loosen the mounting knob behind the head, tilt the head slightly to one side, and tighten.</li> <li>5. Clincher is worn. Replace clincher.</li> <li>6. Excessive compression. Adjust clincher downward or set head actuating bar higher.</li> </ol>
<p>9. Stitches come out in pieces.</p> 	<ol style="list-style-type: none"> <li>1. Improperly aligned rotator. Loosen screw, item 29 on page 14, and slide rotator holder, item 28, in or out until rotator is properly aligned with bender bar, item 46. The wire grooves in the bender bar must be directly above a straight piece of wire being held in the rotator.</li> <li>2. Rotator operating spring is weak. Replace rotator operating spring, item 27 on page 14.</li> <li>3. Wire is jammed in bender bar grooves. Remove pieces of wire stuck in the bender bar grooves or replace bender bar, item 46 on page 15.</li> <li>4. Wire is wrong size or poor quality. Use only approved stitching wire: part number 25G5.</li> </ol>
<p>10. Straight pieces of wire fall from the head.</p> 	<ol style="list-style-type: none"> <li>1. Rotator is dirty. Carefully remove, clean, and lubricate rotator. See lubrication instruction C and picture on page 6.</li> <li>2. Rotator is broken or worn. Replace rotator, item 30 on page 14.</li> <li>3. Improperly aligned rotator. Loosen screw, item 29 on page 14, and slide rotator holder, item 28, in or out until rotator is properly aligned with bender bar, item 45. The wire grooves in the bender bar must be directly above a straight piece of wire being held in the rotator.</li> </ol>
<p>11. One or both legs are bent towards the front or rear.</p>  <p>Top View</p>	<ol style="list-style-type: none"> <li>1. Stitcher head is not aligned front to back with clincher. Remove stitcher head from parent machine and adjust the two bonnet aligning screws, item 12 on page 14. Adjust the screws by an increment of less than a full turn. Install head and check results. Repeat process if necessary.</li> </ol>
<p>12. Wire buckles above the grip, item 55 on page 11 and below the feed tube, item 3 on page 12.</p>	<ol style="list-style-type: none"> <li>1. Driver bar is worn. Replace driver bar, item 47 on page 15.</li> <li>2. Latch assembly is worn. Replace latch assembly, item 48 on pg.15.</li> <li>3. Friction plug is worn. Replace friction plug, item 49 on page 15.</li> <li>4. Friction plug spring is weak or broken. Replace spring, item 50 on page 15.</li> </ol>

# HIGH PERFORMANCE

TROUBLE	POSSIBLE CAUSE & REMEDY
13. Wire buckles below the grip, item 61 on page 15 and above the wire cutters, item 22 on page 14.	<ol style="list-style-type: none"><li>1. Improperly aligned rotator. Loosen screw, item 29 on page 14, and slide rotator holder, item 28, in or out until rotator is properly aligned with bender bar, item 47. The wire grooves in the bender bar must be directly above a straight piece of wire being held in the rotator.</li><li>2. Wire cutters are dull or broken. Replace wire cutters, item 22 on page 14.</li><li>3. Cutter operating slide is worn or broken. Replace cutter operating slide, item 19 on page 14.</li><li>4. Wire cutter slot in face plate is worn. Replace face plate, item 1 on page 18 or replace entire face plate assembly, item 25 on page 14.</li><li>5. Check pawl is worn or dirty. Clean check pawl assembly, item 37 on page 14. Replace worn check pins, or replace check pawl assembly</li><li>6. Burrs exist on funnel in rotator. Polish rotator, item 30 on page 14.</li></ol>

# ADJUSTMENTS

## TO BALANCE STITCH LEGS:

If the stitch legs are uneven in length as pictured, use the following procedure to balance the leg length.



1. Loosen the leg balance block screw (Index 8, page 14).
2. Turn the adjusting screw (Index 41, page 15) clockwise to shorten the left stitch leg or counter clockwise to lengthen the left leg.
3. Tap leg balance block (Index 42, page 15) down before tightening the screw (Index 8, page 14).

---

## WIRE DRAW ADJUSTMENT:

How to change the wire draw length for the thickness of the work being stitched.

The Stitcher head is equipped with a 3 position eccentric Adjuster Lever Assembly (CAA176) See CAAA2006W Figure 1. This lever changes the length of wire used to stitch the book.

The down position results in the shortest length of wire for stitching books with 2-10 sheets.

The middle position results in a medium length of wire for stitching books with 10 - 15 sheets.

The up position results in the longest length of wire for stitching books with 15-25 sheets.

3-4 sample books should be stitched and inspected to see a change in the wire length inside the book.

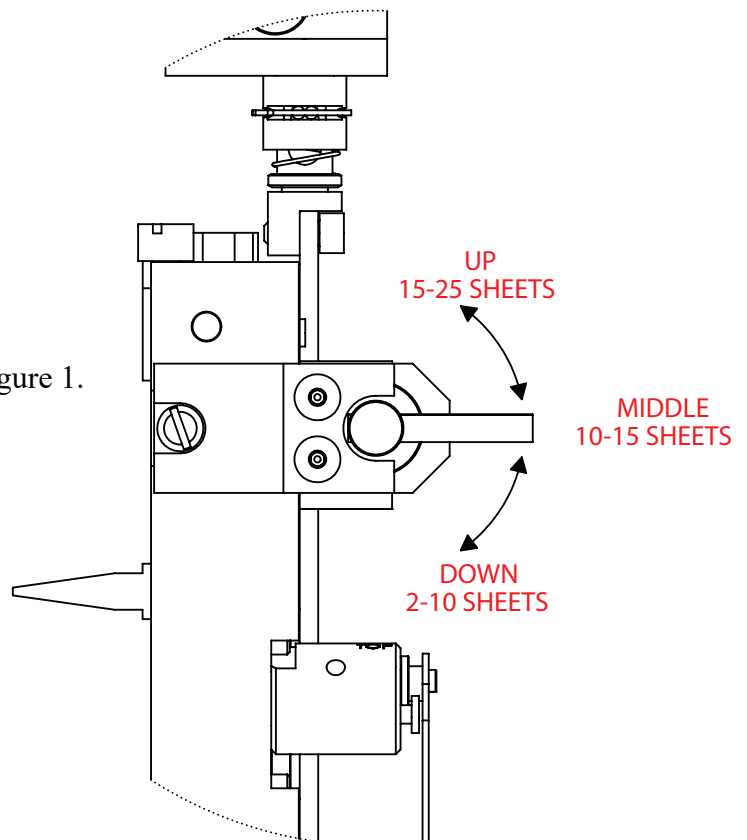

Figure 7.

# HIGH PERFORMANCE

## STITCHING HEAD ASSEMBLY

### CAAA2006W

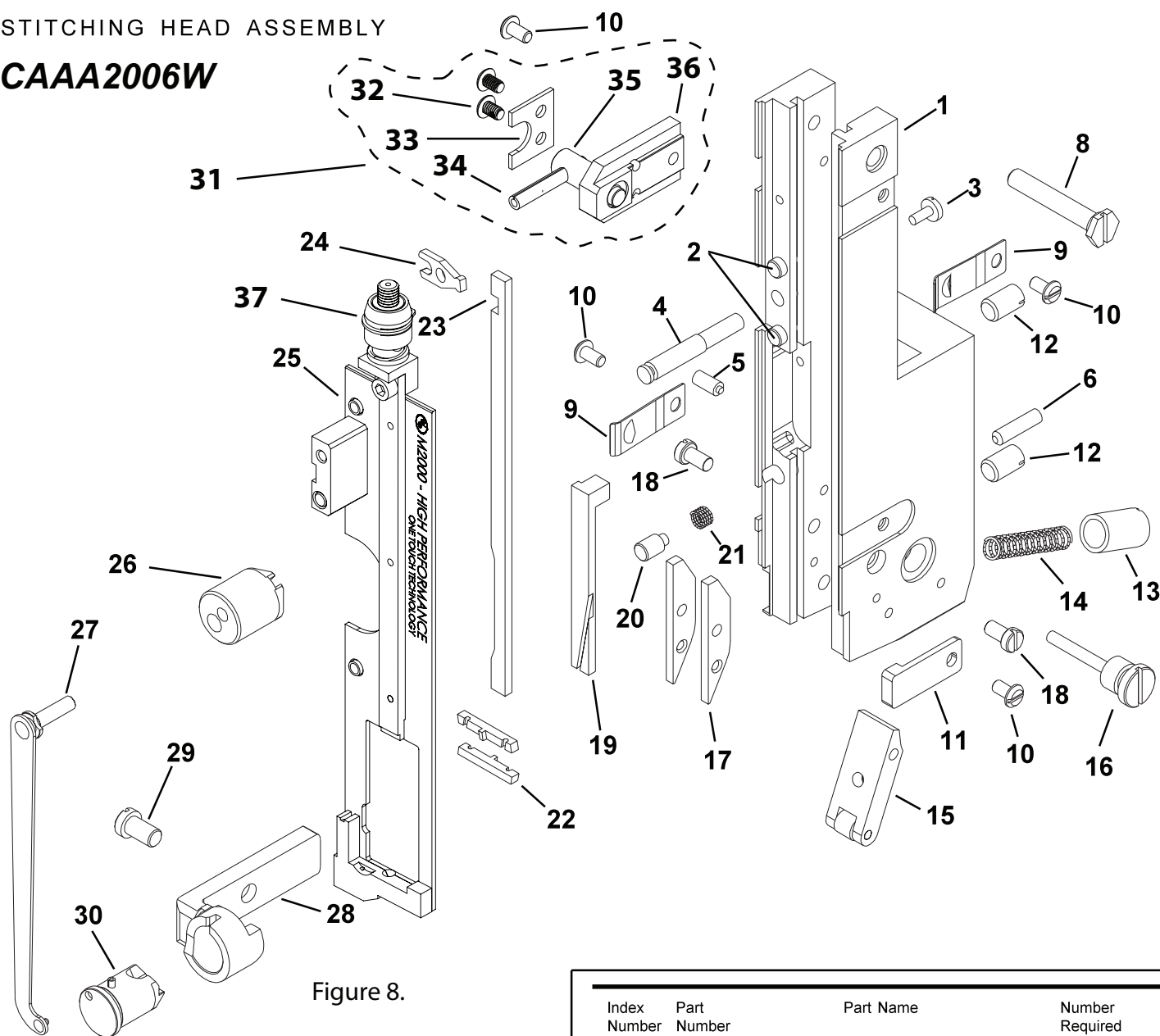

Figure 8.

Index Number	Part Number	Part Name	Number Required
1	CA2004G	Bonnet, Easy Thread, Bolt-On (Includes Items #2 to #6)	1
2	CA9139	Stop Pin	2
3	CA9058	Screw	1
4	CA9127	Cam Stud	1
5	CA157	Screw, 10-32x.375 Set	1
6	CA156	Screw, Supporter Lever Adj.	1
8	CA9075	Leg Balance Block Screw	1
9	CA9056C	Face Plate Clip	2
10	CA2081	Clip Screw	4
11	CA9056A	Face Plate Clip	1
12	CT9109	Bonnet Aligning Screw	2
13	CA9037	Supporter Spring Bushing	1
14	CA9032C	Supporter Spring	1
15	CAA9036	Supporter Spring Lever	1
16	CA9034	Supporter Spring Lever Screw	1
17	CA9030	Supporter Guide Plate	2

Index Number	Part Number	Part Name	Number Required
18	CA9081	Supporter Guide Plate Screw	2
19	CA9049	Cutter Operating Slide	1
20	CA9050A	Friction Plug	1
21	CA9051A	Friction Plug Spring	1
*22	CA9048	Wire Cutter	2
23	CA9022L	Grip Release Slide	1
24	CA9025	Grip Release Slide Adj Lever	1
25	CAAA2132U2	Face Plate Assembly EZ (See page 18 for details.)	1
26	CA9163C	Rotator Operating Cam	1
27	CAA9046D	Rotator Operating Spring	1
28	CA9043L	Rotator Holder	1
29	CA9044A	Rotator Holder Screw	1
30	CAA9038E	Magnetic Rotator	1
31	CAA176	Adjuster Bracket Assembly (includes items #32 thru #36)	1
32	DW1056	Screw, Button Head 8-32 X 1/4	2
33	CA177	Shaft Retainer	1
34	CB835T2	Roll Pin, .187 X 1.250	1
35	CA9648A	Adjustment Shaft EZ	1
36	CA176	Adjuster Bracket	1
37	CBBB513G	Check Pawl Assy.	1

# CAA2006W

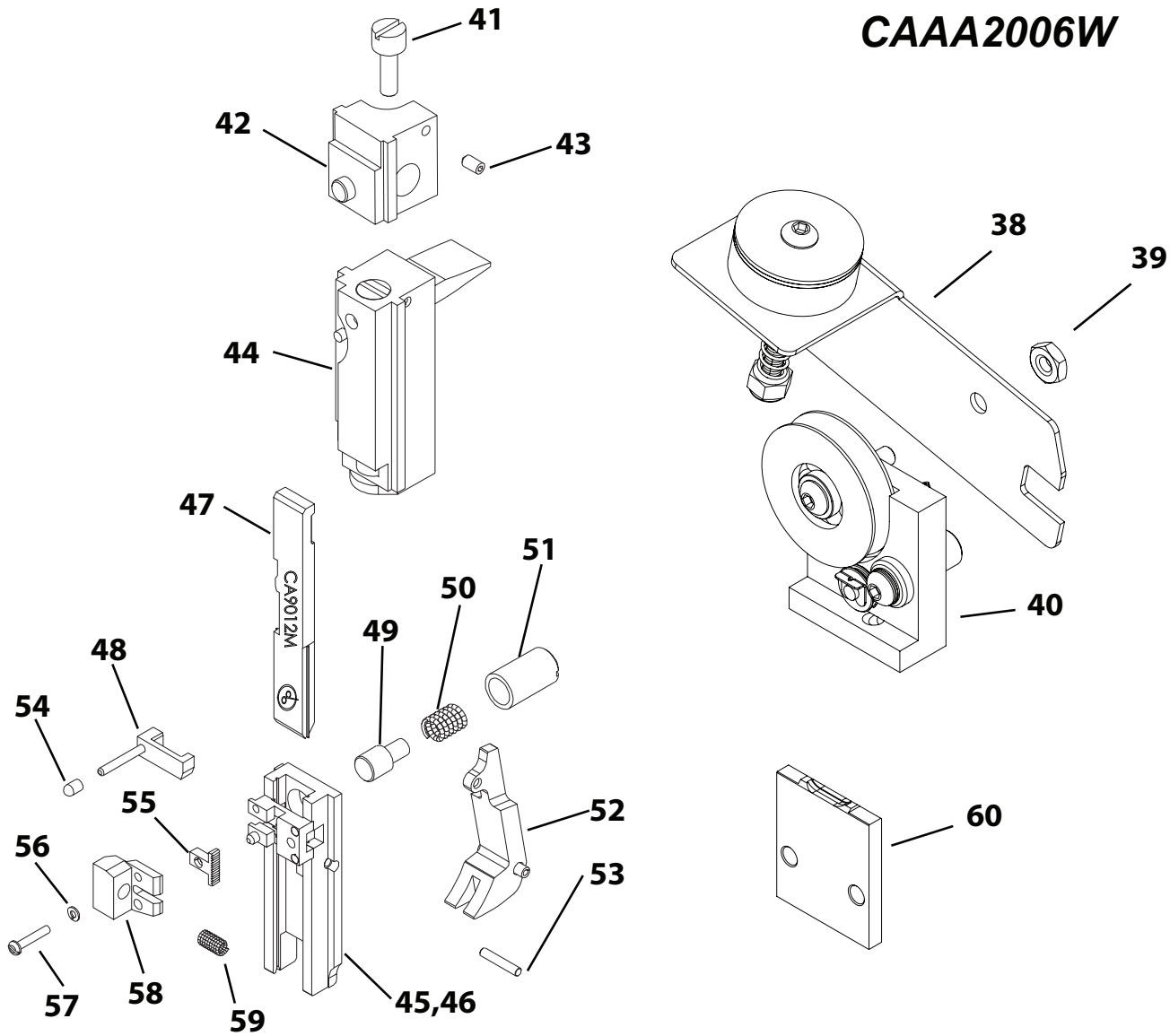

Figure 9.

Index Number	Part Number	Part Name	Number Required
38	RBM1894A	Oiler Bracket Assembly	1
39	CB278	Nut, 10-32 Hex.	1
40	RBM1678A	Wire Guide Assembly (See page 19 for details)	1
41	CA9076	Adjusting Screw	1
42	CAA9074C3	Leg Balance Block Assy	1
43	D31028F	Set Screw	1
44	CTT2623J	Driving Slide Assembly	1
45	CAA9013S3	Bender Bar Assembly 1/2" (Includes Items #45 thru #58)	1
46	CAA9013S2	Bender Bar	1
*47	CA9012M	Driver Bar	1
48	CAA9014J	Latch Assy	1

Index Number	Part Number	Part Name	Number Required
49	CA9112A	Friction Plug	1
50	CA9113A	Spring	1
51	CA9115	Bushing	1
52	CAA9026	Supporter	1
53	CA9029	Pivot Pin	1
54	CA173	Black Cap	1
*55	CA9015D	Grip	1
*56	CB371K	Lockwasher	1
*57	CA9024A	Screw	1
58	CT413A	Grip Spring Housing	1
*59	CA168	Grip Spring	1
60	CT9086X	Solid Clincher	1

\* Recommended Parts to Replace at First Overhaul

# HIGH PERFORMANCE

## STITCHING HEAD ASSEMBLY

**CTTT2606W**  
**CTTT2606P**

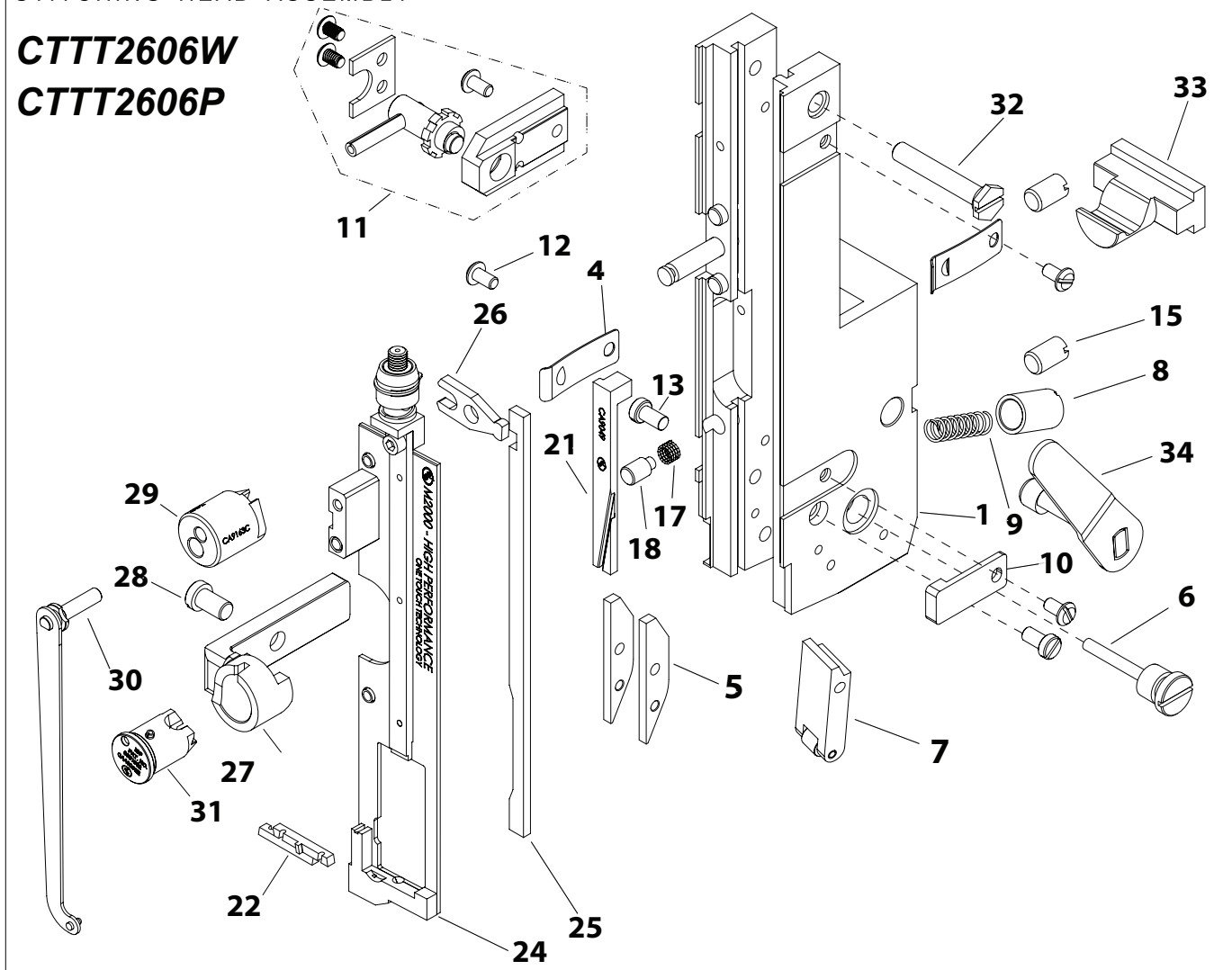

Index Number	Part Number	Part Name	Number Required
1	CTT2604K	Bonnet, Easy Thread	1
4	CA9056C	Face Plate Retaining Clip	3
5	CA9030	Supporter Guide Plate	2
6	CA9034	Supporter Spring Lever Screw	1
7	CAA9036	Supporter Spring Lever Assy	1
8	CA9037	Supporter Spring Bushing	1
9	CA9032C	Compression Spring	1
10	CA9056A	Face Plate Retaining Clip	1
11	CAA176	Adjuster Assy	1
12	CA2081	Face Plate Clip Screw	4
13	CA9081	Supporter Guide Plate Screw	2
15	CT9109	Bonnet Aligning Screw	2
16	CA9058	Swivel Operating Cam Stud Screw	1
17	CA9051A	Friction Spring	1
18	CA9050A	Friction Plug	1

Index Number	Part Number	Part Name	Number Required
21	CA9049	Wire Cutter Operating Slide 1/2"	1
*22	CA9048	Wire Cutter	2
24	CAA2132U2	Face Plate Assy	1
25	CA9022L	Grip Release Slide	1
26	CA9025	Grip Release Adj. Lever	1
27	CA9043L	Rotator Holder	1
28	CA9044A	Rotator Holder Screw	1
29	CA9163C	Swivel Lever Hub	1
30	CAA9046D	Rotator Operating Spring	1
31	CAA9038E	Rotator Assembly 1/2" - M2000	1
32	CA9075	Wire Guide Spring Bracket Screw	1
33	CTT9002	Bonnet Clamp Block	1
34	CTT9003C	Bonnet Clamp Eccentric Handle	1



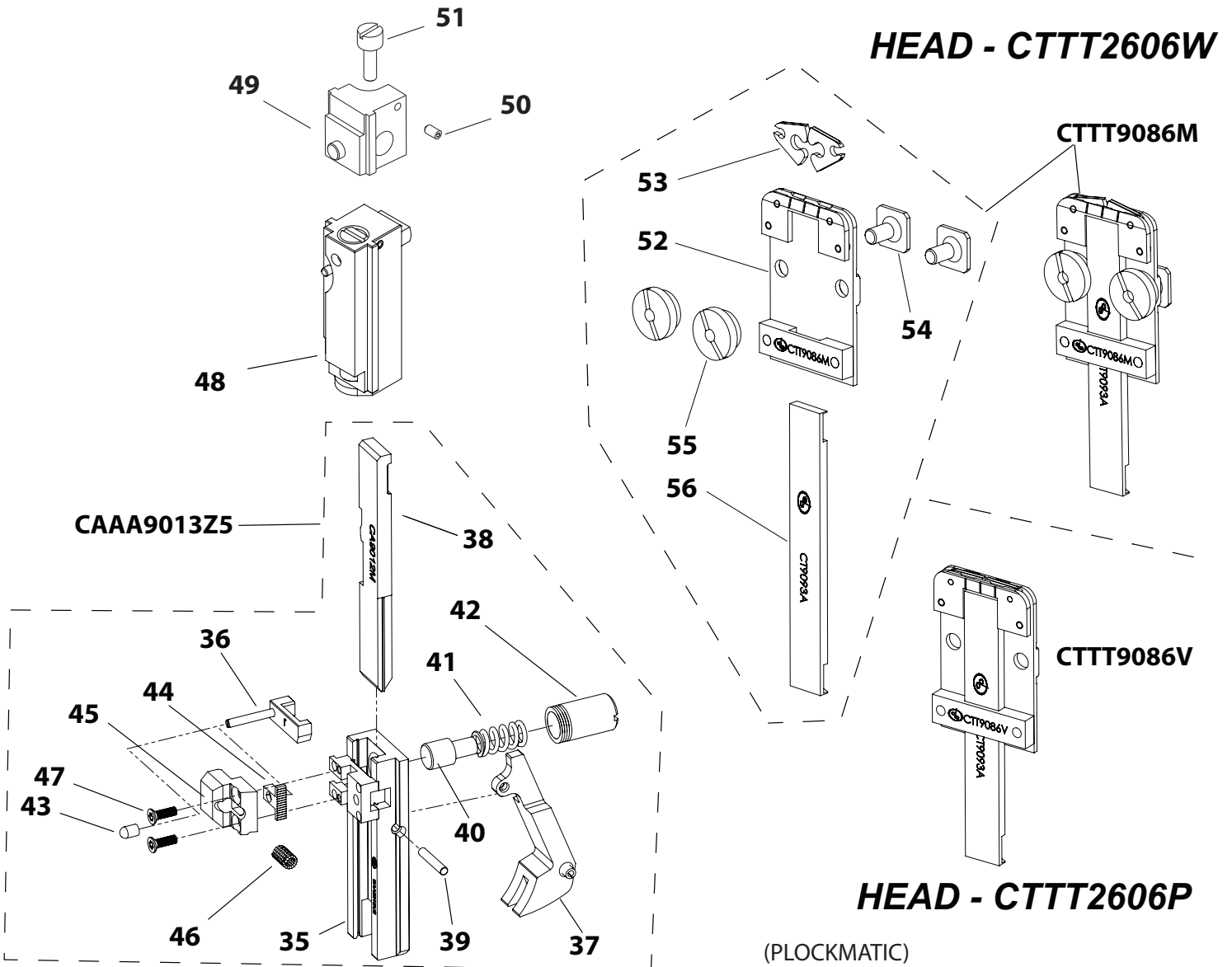

Index Number	Part Number	Part Name	Number Required
35	CAA9013U5	Bender Bar Assembly	1
36	CAA9014J	Latch Assembly	1
37	CAA9026	Supporter Assembly	1
*38	CA9012M	Driver Bar M2000	1
39	CA9029	Pin	1
40	CA9112A	Bender Bar Friction Plug	1
41	CA9113A	Bender Bar Friction Spring	1
42	CA9115	Friction Plug Bushing	1
43	CA173	Latch Pin Cap	1
*44	CA9015D	Grip, M2000	1
45	CT413E	Housing, Spring	1
*46	CA168	Grip Spring	1
*47	CA9024E	Screw, M2.5 x 0.45 x8 FHM-TORX	2
48	CTT2623	Driving Slide Assembly	1
49	CAA9074C3	Leg Balance Block Assembly	1

Index Number	Part Number	Part Name	Number Required
50	D31028F	Hex Socket Screw, 6-32 x 1/4	1
51	CA9076	Adjusting Screw	1
52	CTT9086M	Clincher Plate Assembly	1
*53	CA9083A	Clincher Point 1/2" Crown, Thick	2
54	CT9088	Clincher Plate Binder Bolt	2
55	CA2091	Clincher Plate Binder Nut	2
56	CT9093A	Clincher Slide, Thick	1

\* Recommended Parts to Replace at First Overhaul

# HIGH PERFORMANCE

## CAA2132U2 FACE PLATE ASSEMBLY

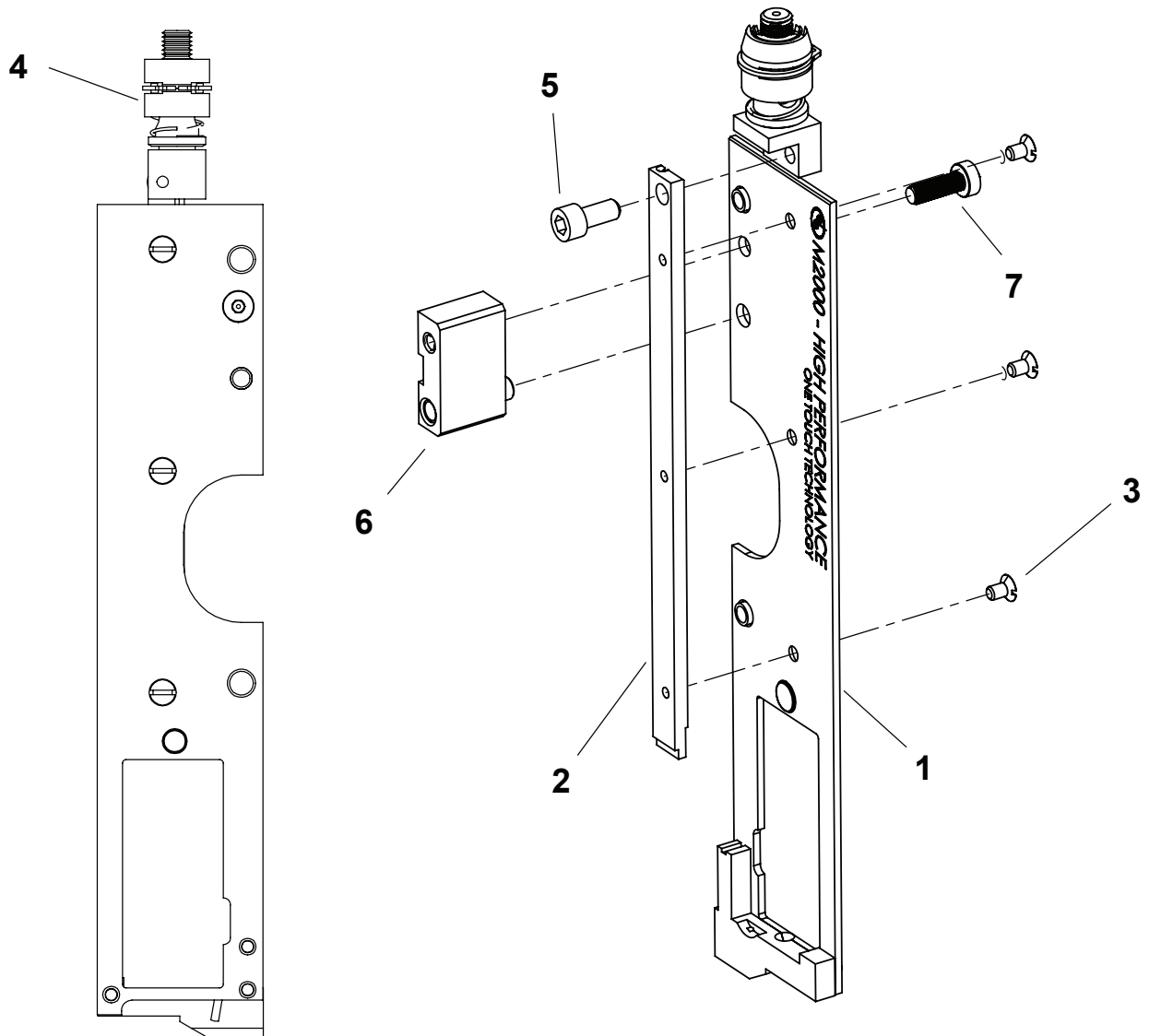

Figure 10.

Index Number	Part Number	Part Name	Number Required	Index Number	Part Number	Part Name	Number Required
1	CAA2132R2	Face Plate Sub Assembly - EZ	1	6	CA174A	Slide Bar Assembly	1
2	CA182A	Feed Tube	1	7	G20176	Screw M4x0.7x12, Low, Nylon	1
3	CA9643	Flat Head Screw	3				
4	CBBB513G	Check Pawl Assembly	1				
5	D30676F	Cap Screw	1				

# WIRE GUIDE ASSEMBLY

## RBM1678A with CTTT2133A2

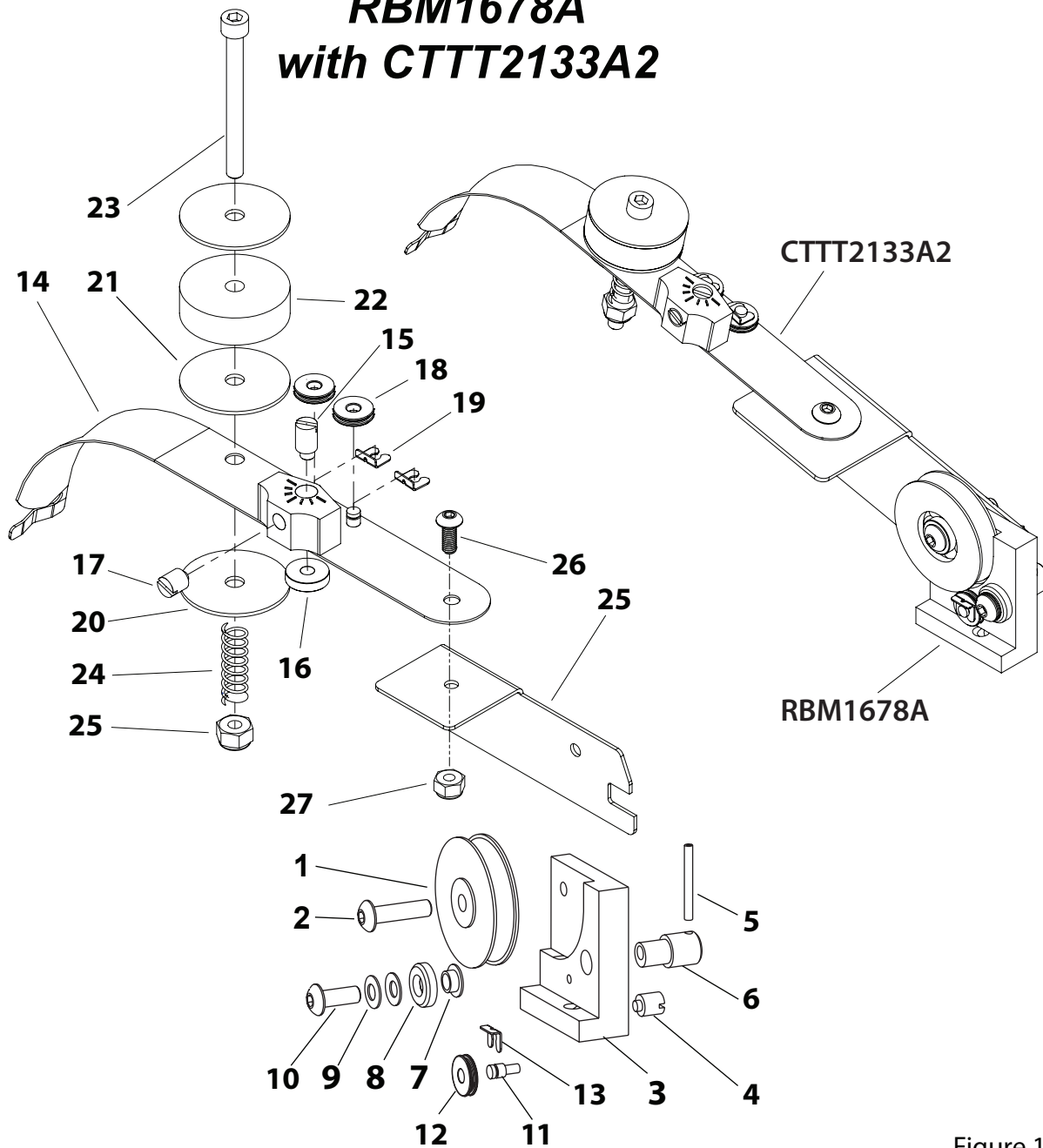

Figure 11.

Index Number	Part Number	Part Name	Number Required	Index Number	Part Number	Part Name	Number Required
1	RBM1677F	Wire Guide Pulley	1	15	CA9066A	Wire Straightener Eccentric	1
2	CG26 B	Button Hd Scr 10-32 x	1	16	CA9065A	Wire Straightener Roll	1
3	RBM1647F	Straightener Bracket	1	17	CA172	Set-Screw, Nylon Tip	1
4	CA172	Soft Tip Set Scr 1/4-20	1	18	CA9103C	Wire Straightener Roll	2
5	D41302F	Roll Pin	1	19	CA9124	Wire Straightener Roll Clip	2
6	RBM1423F	Straightener Eccentric	1	20	CA9651	Washer #10	2
7	CA9068	Bushing	1	21	CA9653	Felt Washer, Thin	1
8	CA9065	Roller	1	22	CA9652	Felt Washer, Thick	1
9	CL44A	Spring Washer	2	23	CB651E	Screw, 10-32 x 2.000	1
10	RBM1424F	Button Head Screw	1	24	CA9032C	Compression Spring	1
11	CA9123A	Stud	1	25	RBM1894F	Oiler Bracket	1
12	CA9103C	Roll	1	26	CG26	Screw, 10-32 x 3/8	1
13	CA9124	Clip	1	27	CB860B	Elastic Stop Nut 10-32	1
14	CTT2133A2	Wire Guide Spring Sub-Assembly	1				

WHEN ORDERING PARTS, PLEASE STATE: QUANTITY REQUIRED, PART NUMBER, PART NAME, WIRE SIZE AND CROWN WIDTH OF YOUR STITCHER.



COMPANY INC.

**ISP** solving your wire stitching needs for 125 years...  
**Stitching & Bindery Products**

3747 Acorn Lane • Franklin Park • Illinois 60131

Phone: 847-455-4400 • 800-634-0810

Fax: 847-455-4900 • 800-417-9251

<http://www.deluxestitcher.com>