

ISP Stitching & Bindery Products

A Division Of Samuel Strapping Systems

OWNERS

MANUAL

220V, 50HZ



ISP Stitching & Bindery Products

Stitch'n Fold

CONTENTS

Introduction	3
Specifications	3
Safety	4
Assembly Drawing	5
Installation	6
Preventive Maintenance	6
Control Panel.....	7
Operation & Setup	8
Side Stitching	9
Corner Stitching	10
Adjustments	11
Clutch Shear Pin Replacement	12
Trouble Shooting	14
Exploded Drawings & Parts Lists	16
Electrical Schematic.....	31

INTRODUCTION

Simple Operation: Just load your booklet and it is automatically jogged, stitched, folded, and discharged onto an accumulating output conveyor. Side stitching, corner stitching, and folding projects, with or without stitching, are easily accomplished.

Advanced Technology: *Stitch'n Fold* uses ISP's patented magnetic stitching head technology, providing the reliability and economy of wire stitching. Dual sets of folding rollers assure consistent, professional results. For safety, interlocked access guards prevent machine operation when open.

Improved Productivity: With *Stitch'n Fold*, you can jog, stitch, and fold more than 65,000 booklets at a maximum speed of 2,000 finished booklets per hour - without stopping to reload staples. *Stitch'n Fold's* variable work thickness capacity handles from 2 sheets to a one hundred page booklet with no setup changes or adjustments.

Lower Operating Costs: The *Stitch'n Fold* replaces expensive preformed staples with inexpensive bookbinding wire; you save on material costs and nonproductive downtime.

SPECIFICATIONS - MODEL:B1000

Unit Weight:	191 Pounds
Speed:	Up to 2,000 booklets per hour
Capacity:	2 to 25 sheets of 20# bond (100 page book)
Re-load:	65,000 booklets per spool of wire
Paper Size:	Min. 5.5" x 8.5" Max. 11" x 17" (also: A5 to A3)
Booklets:	Min. 4.25" x 5.5" Max. 8.5" x 11"
Stitch Space:	5.5" on 8.5" or 11" tall books 2.75" on 5.5" tall books
Counter:	Resettable 6-digit electronic counter
Folder:	Knife/Buckle folder with dual folding rollers
Squaring:	Side jog plus full length tape feed
Output:	Continuous conveyor
Footprint:	20" x 30"
Dimensions:	Height 30" Width 20" Depth 50"
Modes:	Stitch and Fold, Stitch, Fold, Corner Stitch, Side Stitch
Electrical:	Standard outlet - 220 Volts, 50 Hz, 10 Amps (1/4 HP)

Stitch'n Fold

SAFETY

SAFETY PRECAUTIONS AND PROCEDURES

1. *Make sure electrical power is turned off before performing any adjustment or maintenance.*
2. *Keep hands, hair, tools, and clothing clear of stitching area.*
3. *Become familiar with the moving components of your machine. Keep fingers away from areas that could pinch or cut.*
4. *A well maintained machine is a safer machine. Clean and lubricate the machine at regular intervals. Check machine daily for broken or worn parts. Replace as necessary. DO NOT attempt to operate the machine if a part is broken.*
5. *See "SAFETY GUARDS" below! If you are unsure how to safely operate your Bookletmaker, contact your Service Representative.*



KEEP HANDS CLEAR OF STITCHING AREA AND ANY MOVING PARTS!

NEVER OPERATE MACHINE WITHOUT ALL GUARDS IN PLACE!

SAFETY GUARDS

- A. Clear Plastic Front Guard: Blocks access to point of operation of stitching heads. An electrical interlock keeps the machine turned off unless this hinged guard is closed. Do not stick your fingers under the front guard!
- B. Clear Plastic Top Guard: Blocks access to mechanism that drives the stitching heads. An electrical interlock keeps the machine turned off unless this guard is closed. Do not stick your fingers under the top guard!
- C. Vacant Head Guards: Close gaps in top guard. One of the inverted "L" shaped guards is mounted in each empty stitching head position. Whenever the stitching heads must be repositioned for a new job, remove the guard from the spot where the head needs to be, and remount the guard in the vacated spot.
- D. Right Side Cover: Blocks access to mechanisms that can pinch or cut.
- E. Left Side Cover: Blocks access to dangerous electric voltage and mechanisms that can pinch or cut. Be sure to disconnect electrical power before removing this cover.
- F. Front Cover: Blocks access to dangerous electric voltage and mechanisms that can pinch or cut. Be sure to disconnect electrical power before removing this cover.
- G. Rear Cover: Blocks access to mechanisms that can pinch or cut. Do not stick your fingers beyond this cover!
- H. Belt Guard: Blocks access to a pinch point.
- I. Sensor Guard: Blocks access to low voltage connection.
- J. Discharge Guard: Blocks access to pinch points.

ASSEMBLY DRAWING

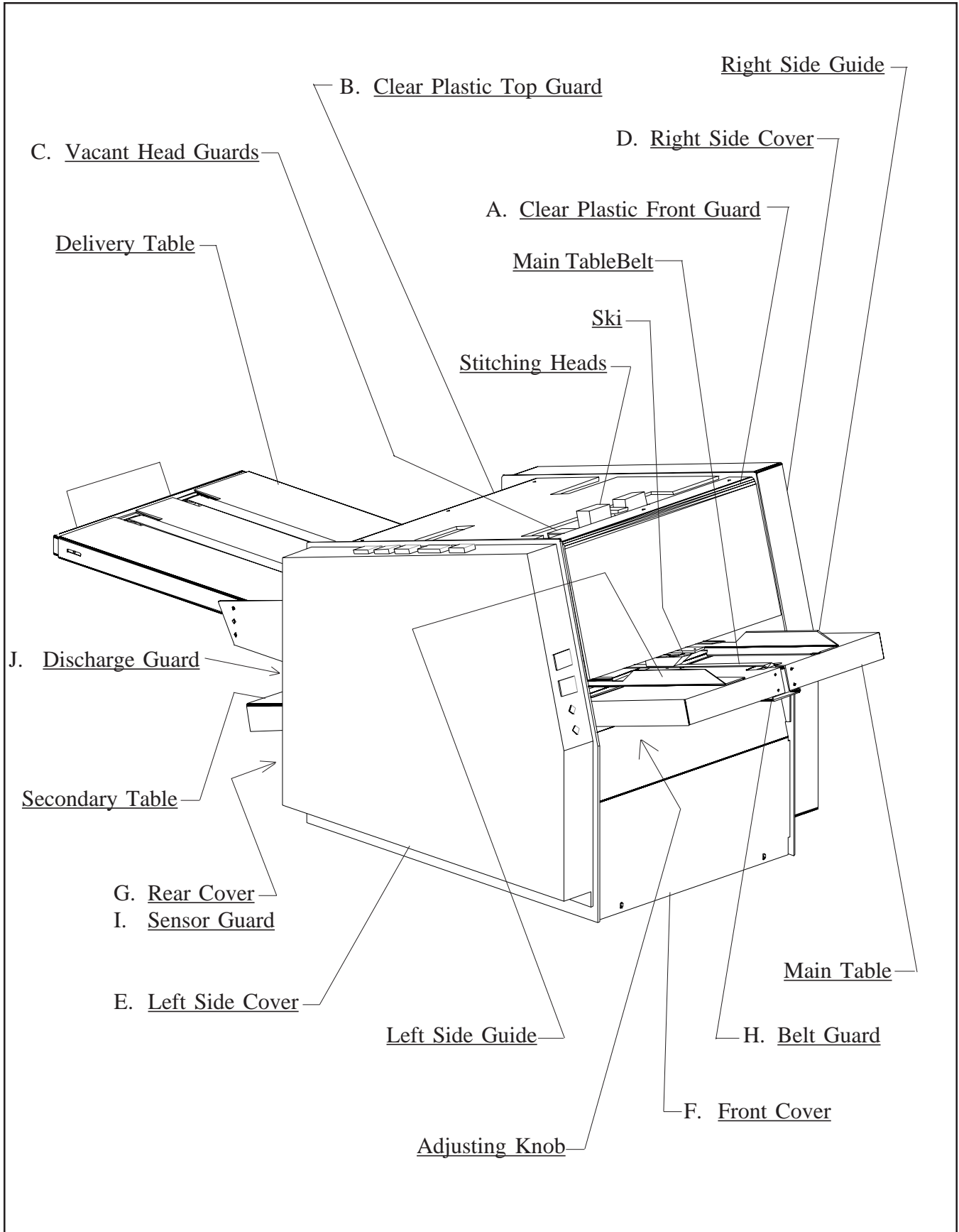

Stitch'n Fold

INSTALLATION

BEFORE UNCRATING:

Examine the crate for visible damage. If the crate is damaged, the machine might be damaged. Notify the carrier who delivered the machine.

UNCRATING THE MACHINE:

Carefully remove the machine from its container. Lift the machine by grasping its strong framework. Tugging on cables, covers, or other delicate components could cause damage.

Examine the machine for damages incurred during shipping. Do not install a damaged machine. Notify the carrier immediately.

Be sure to get a signed copy of the Carrier Inspector's Report of the damage incurred. Your service representative will assist you in determining the cost of repairs.

ELECTRICAL POWER:

The power cord can be plugged into any 220V, 50 Hz, 1 Phase, 10 Amp circuit. The machine draws less than 10 amps.

LOADING WIRE:

Use only approved stitching wire, part number 415-0225. Lift the top plastic guard to reach the wire spool studs. The first items on each stud should be the conical spring followed by a white plastic washer. Next goes the coil of stitching wire followed by a large plastic washer. Finally, a retaining pin holds everything in place.

The coils of stitching wire should be mounted so the wire comes off upward from the backside.

To thread the wire into the stitching heads, see instructions in the stitching head owners manual.

PREVENTIVE MAINTENANCE

LUBRICATION:

Disconnect electrical power. Next, remove the front cover. Provide table space to lay down the left side cover next to the machine; they are connected by electrical wires. Remove both side covers.

Use SAE-20 oil to lubricate porous bronze bearings, needle bearings, chains, and shafts.

Use approved stitcher head lubricant, part number CA9640, to lubricate the stitching heads every time a new coil of stitching wire loaded. Clean and lubricate the magnetic rotator. Lubricate the driver bar and the bender bar latch. See stitching head owners manual.

CLEANING:

Use alcohol to clean the belts.

Use a 50-50 mixture of alcohol and water to clean the folding rollers.

MAIN CONTROL PANEL

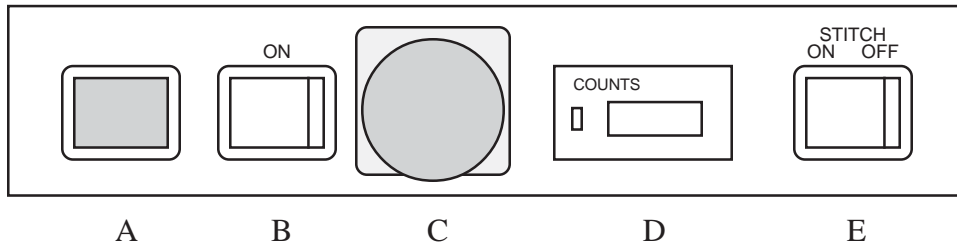

- A. Pilot Light: Glows to indicate that electrical power is turned on.
- B. Power On: Black rocker switch turns on power. Pilot glows; motor runs if motor selector switch is in "On" position.
- Note: Opening the front or top plastic guards shuts off the machine.
- C. Emergency Stop: Red push-button switch cuts off power. To release emergency stop, turn push-button clockwise.
- D. Counter: Digital counter records the number of sets that pass through the machine. A manual reset button returns the counter to zero after each job. The reset button can be locked to prevent accidental reset.
- E. Stitch On/Off: Selector switch chooses mode of operation: "On" for stitching jobs or "Off" for folding without stitching.

AUXILIARY CONTROL PANEL

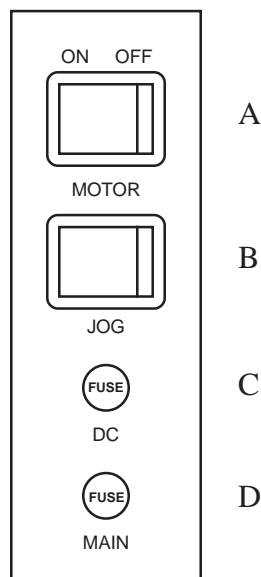

- A. Motor On/Off: Selector switch allows motor to be turned off with power still turned on.
- B. Motor Jog: Rocker switch cycles the stitchers. First, turn off motor. Then, slide a sheet of paper into the stitching position until it trips the limit switch by the gate (4LS). Now, press and quickly release the jog switch to cycle the stitchers.
- C. DC Fuse: Fuse protects transformer. If this fuse fails, none of the 24VDC components will operate. Replace with proper .4A fuse.
- D. Main Fuse: Fuse protects entire machine. If this fuse fails, power cannot be turned on. Replace with proper 10A fuse.

Stitch'n Fold

OPERATION & SETUP

Bookletmaking & Basic Adjustments

See Following Sections For Corner Stitching Or Side Stitching

BOOKLETMAKING

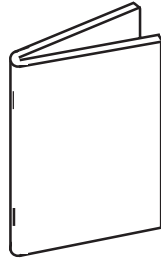

STITCHING HEADS:

Make sure the stitching heads are mounted in the proper positions to match the paper size. For 5.5" x 8.5" (also A5) paper, the heads must be mounted in the two positions closest to the belt on the main table. One head is mounted just to the left of the belt, and the other head is mounted just to the right of the belt. These head locations will provide a stitch spacing of 2.75". For 8.5" x 11" or 11" x 17" (also: A4 or A3) paper, each head is mounted in the second position to the left and the right of the center belt. These head locations provide 5.50" stitch spacing.

To move a stitching head to a new position, first lift open the top plastic guard. Loosen and remove the knob/bolt from the back of the head. Pull the head forward until it comes off of the locating pin, and slide it over to the desired location. Slip the head onto the new locating pin, and be sure that the driving lug on the upper backside of the head engages the slot in the head driving bar. Replace the knob/bolt (and its washer and lockwasher), and tighten it securely.

PAPER WIDTH:

Adjust the side guides for paper width. For instance, if 8.5" x 11" paper is being used to make a 5.5" x 8.5" booklet, the side guides must be set for the 8.5" width. First, lift open the front plastic guard. Loosen the thumb screw on each side guide, and slide each guide sideways until its inner edge is aligned with the 8.50" mark on the scale

on the main table. Note: the space between the side guides will be about .30" more than the paper width. This extra space allows for the right side guide to jog the paper before it is stitched.

PAPER LENGTH:

Adjust the gates for paper length. For instance, for 8.5" x 11" paper, the gates must be set for the 11" length. Place a sheet of paper on the main table between the side guides and slide it under the ski until it stops against the first gate. While holding the paper against the gate, turn the adjusting knob under the left hand side of the table until the paper is aligned with the 11" mark on the scale. (Clockwise rotation moves the paper out.) This single adjustment takes care of both the stitching gate and the folding gate. Also, see Timer Gate Adjustment on page 11.

Adjust the booklet tray at the end of the delivery table to match the booklet size. Loosen the knob under the tray, and slide the tray to the proper position.

Finally, adjust the position of the delivery table wheels. Loosen the thumb screw between the wheels, and slide the wheels to a position that suits the booklet size.

OPERATION & FINE ADJUSTMENT:

Turn on power and select "STITCH ON" and "MOTOR ON". Square up a set of paper sheets by hand, and lay the front edge on the table between the side guides. Push until the front edge is under the ski, and then let go. The set will be automatically stitched, folded, and ejected onto the output conveyor.

Check the finished booklet. If the stitches are properly located on the fold, but the fold is off center (see end view below), adjust the gates by turning the crank until sets will fold precisely in half.

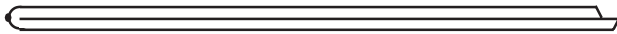

Off Center Fold



Proper Fold

If the stitches are off the fold (see below), open the booklet flat and measure to see if the stitches are centered on the length of the paper. Turn the crank until stitches are placed precisely on the center of the paper. Next, locate the two wing nuts below the back end of the secondary table. Turn both wing nuts equally in small increments until booklets will fold precisely on the stitches.

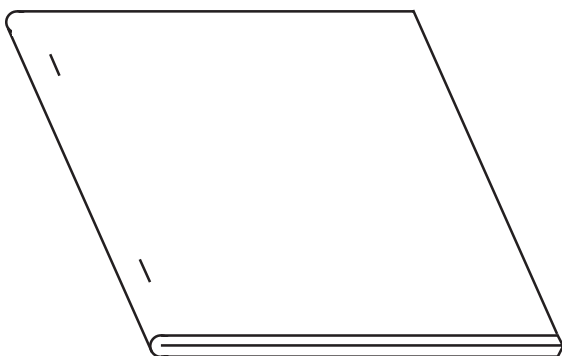

Finally, if the fold is not quite square (see below), the wing nuts can be adjusted individually.

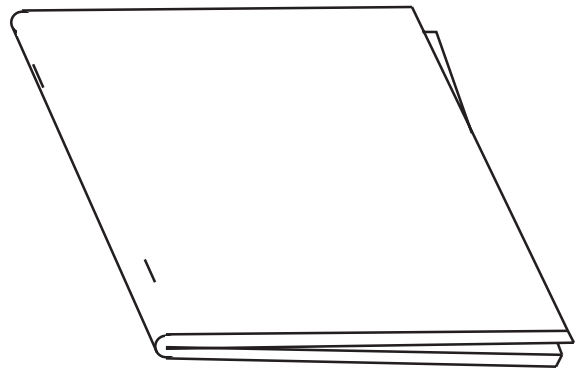

SIDE STITCHING

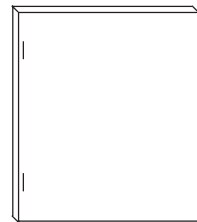

Side stitching can be done with 5.5" x 8.5" or 8.5" x 11" (also: A4 or A5) paper. In either case, mount the heads for 5.50" stitch spacing.

Adjust the side guides for paper length. For instance, if 8.5" x 11" paper is being side stitched, the side guides must be set for the 11" length. Align the inner edge of each side guide with the 11" mark on the table scale.

Adjust the stitching gate for paper width. For instance, for 8.5" x 11" paper, the gate must be set for the 8.5" width. First, lift open the front plastic guard. Place a sheet on the table between the side guides, and slide it under the ski until it stops against the gate. Turn the crank until the trailing edge of the paper is just in front of the clinchers. An alternative method is to set the gate for making booklets with 11" x 17" paper and then turning the crank clockwise to back out the gate about 1/8".

Lower the folding gate by reaching under the secondary table and pressing the hanging latch. The side stitched sets will drop off the end of the secondary table unfolded.

Stitch'n Fold

CORNER STITCHING

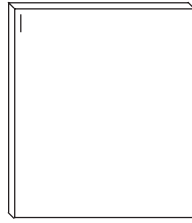

Corner stitching can be done with 5.5" x 8.5" or 8.5" x 11" (also: A4 or A5) paper. In all cases, mount one head in the far left position. The other head may be removed or left in any position without wire.

Two accessory guides must be mounted on the left hand side for corner stitching. First, adjust the standard left side guide as far as possible to the left. Using thumb screws, attach the corner stitch block (inverted "L" shaped part) to the two holes in the left side guide.

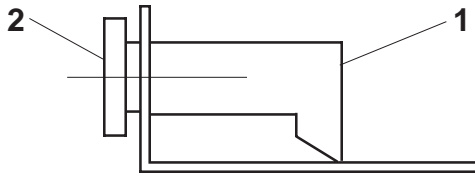

Next, lift open the top plastic guard. Using two thumb screws, attach the corner stitch guide (11" long bar) to two holes in the table on the far left under the coil of stitching wire. The angle on the bar should face the front and middle of the machine.

Adjust the right side guide for paper length. For instance, if 8.5" x 11" paper is being corner stitched, the side guide must be set for the 11" length. Align the inner edge of the right side guide with the table scale as follows:

11" paper	11" mark
8.5" paper	6" mark
A4 paper	12.38" mark
A5 paper	6.54" mark

instance, for 8.5" x 11" paper, the gate must be set for the 8.5" width. First, lift open the front plastic guard. Place a sheet on the table between the side guides, and slide it under the ski until it stops against the gate. Turn the crank until the trailing edge of the paper is just in front of the clinchers.

Lower the folding gate by reaching under the secondary table and pressing the hanging latch. The corner stitched sets will drop off the end of the secondary table unfolded.

Index Number	Part Number	Part Name	Number Required
1	RBM1341F	Corner Stitch Block	1
2	CGG44B	Thumb Screw	2
*	RBM1322F	Corner Stitch Guide	1
*	CGG44	Thumb Screw	2
* Not shown.			

10 Adjust the stitching gate for paper width. For

ADJUSTMENTS

STITCHING CLUTCH

The stitching heads are controlled by a single revolution wrap spring clutch. This clutch must be adjusted to stop the stitching heads in the proper position. First disconnect electrical power. Then remove the front cover and the right side cover. The clutch is located inside the cabinet on the shaft toward the left side, and it is bronze and black in color.

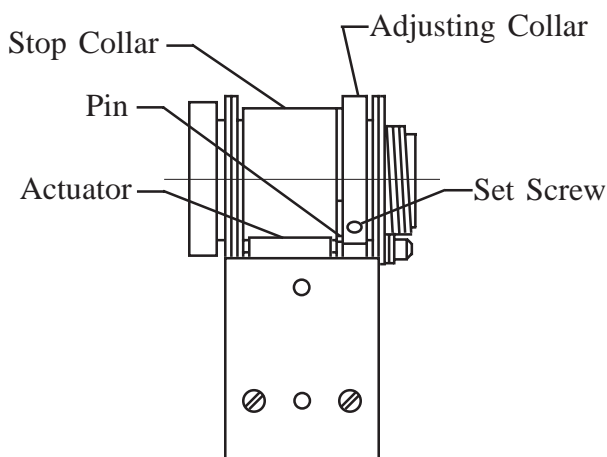

Clutch In Neutral Position

Remove stitching wire from the stitching heads. Trip the clutch by pulling down on the actuator with the tip of a small screw driver. On the right hand side of the machine, slowly turn the large spoked wheel clockwise until the first set screw in the adjusting collar is facing forward. Use a 5/64 hex wrench to loosen the set screw. Continue to turn the wheel until the second set screw is facing forward; loosen the screw.

Turn the wheel until the stop on the stop collar hits the actuator. Now turn the wheel until the proper stopping position is reached. Watch the stitching heads on the up stroke. When the bender bars reach the top of the windows in the face plates, turn the wheel slightly more. Be sure that both wire grips are still open. This is the proper stopping position. If you have gone too far, just continue to turn the wheel until you return to the proper position.

Finally, while still in the proper stopping position, trip the clutch and turn the wheel until one of the set screws is facing forward. Carefully hold the adjusting collar so that the stop collar pin is centered in the opening in the adjusting collar. Tighten the set screw securely. Turn the wheel and trip the clutch, if necessary, until the second set screw can be tightened.

GATE TIMER

The adjusting knob for the gate timer is located on the back of the machine's left side cover. It controls the amount of time that the stop gate is held down each cycle after the stitches have been driven into the booklet. Longer booklets need more time to get past the gate, and the next cycle cannot start until the gate has returned.

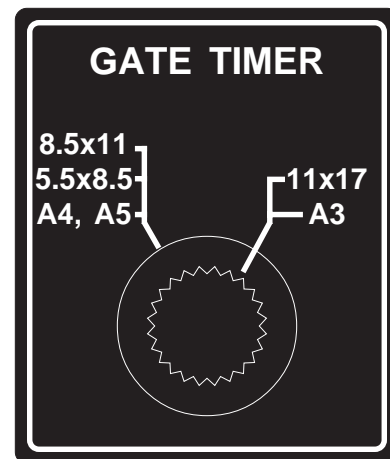

For 11" x 17" paper, set the knob as shown. The knob can be left in this position for other paper sizes, but the gate will be held down longer than necessary. For faster feed rates with smaller paper, turn the knob to the 8.5x11 position.

Stitch'n Fold

REPLACEMENT OF CLUTCH SHEAR PIN

1. Unplug machine.
2. Remove side covers and front cover.
3. See exploded view of head drive shaft on page 22.
4. Disconnect the pull rods from both head drive cranks (#19). Remove the left side head drive crank.
5. Loosen flange bearing set screws (#22) - both right and left sides.
6. Mark the position of the side jog actuator cam (#43), then loosen both set screws.
7. Remove screws (#34) from the switch and clutch bracket (#33), and gently lay the bracket down. There is no need to remove wires.
8. Release the idlers on both drive pulley belts.
9. The head drive shaft (#13) should now move freely from left to right.* Move the shaft to the right just enough to get an allen wrench on the three socket head screws (#31) holding the head drive pulley (#27) to the clutch. Remove all three.
* Note: If the unit has a back jog, it might be necessary to mark the position of the limit switch cams and loosen them in order to move the shaft far enough to the right.
10. Slide the head drive pulley (#27) and the knife drive pulley (#29) to the left.
11. A collar on the stitch clutch (#30) should now be visible. A pin (#37) connects the collar to the shaft. Remove the sheared and replace.
12. Reassemble by reversing the disassembly procedure.

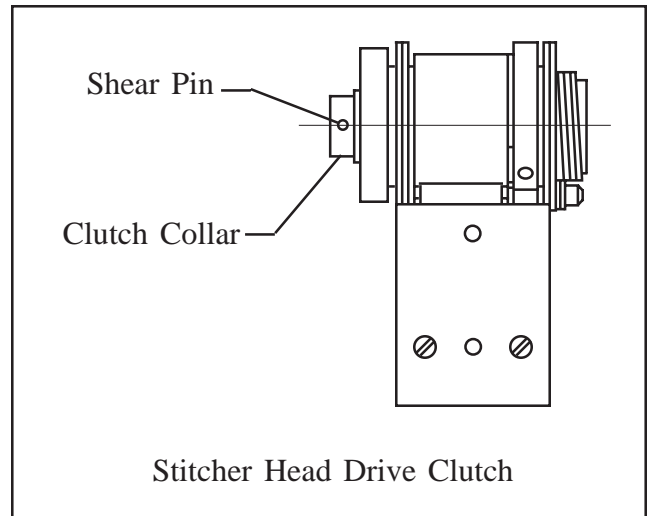

Stitch'n Fold

TROUBLE SHOOTING

PROBLEM:

SOLUTION:

1. Unit will not turn on.	<ol style="list-style-type: none">1. Plug unit into appropriate power supply.2. If green light is on, check "Motor" switch on the front panel and make sure it is in the "on" position.3. If there is no green light:<ol style="list-style-type: none">a. Check for proper line voltage. (115V or 220V)b. Check the "Main" fuse.c. Make sure both plexiglass covers are closed.
2. Book remains in stitching position.	<ol style="list-style-type: none">1. Make sure motor and belt are running. If not, see problem 1.2. Check the "DC" fuse.3. Check the connection to the stitch gate microswitch (4LS).4. Turn to Stitch "off" position:<ol style="list-style-type: none">a. If stitch gate drops when putting a set through the machine, check connections to the stitch clutch.b. If stitch gate doesn't drop when putting a set through, check the stitch gate microswitch (4LS).
3. Book moves slowly through the machine.	<ol style="list-style-type: none">1. Make sure when feeding the book that it gets under the side guides.2. Spray furniture polish or wax on the entry and through the machine. Caution: Do not get polish or wax on paper belt drive.
4. Inconsistent fold.	<ol style="list-style-type: none">1. Use a 50-50 mixture of rubbing alcohol and water to clean all four folding rollers.2. Check and tighten the set screws in all four sprockets that drive the folding rollers.3. Make sure that the spring loaded folding rollers are freely springing out and back.4. Check the folding knife for bends or waviness. Straighten or replace the knife.
5. Stitches are not square to book.	<ol style="list-style-type: none">1. Make sure the stitch stops are square to the clinchers.2. Make sure the side guides are square to the stops.
6. Stitch heads cycle and stop in the down position.	<ol style="list-style-type: none">1. Adjust the stitch clutch according to page 11.

PROBLEM:**SOLUTION:**

7. Stitch heads won't cycle.	<ol style="list-style-type: none">1. Make sure that Stitch on/off switch is in "on" position.2. Check stitch clutch solenoid to see if it is activating when triggered by the stitch gate microswitch (4LS):<ol style="list-style-type: none">a. If solenoid is activating and heads still don't cycle, check stitch clutch shear pin. See page 12.b. If solenoid is not activating, check the stitch clutch connections. There should be 24VDC to the solenoid when it is triggered by 4LS. If the solenoid fails to activate when 24VDC is applied, replace the stitch clutch.
8. Loud banging/clicking noise when stitch heads cycle.	<ol style="list-style-type: none">1. Lubricate head per the "External Lubrication Sheet" provided with the stitch heads. (Lubrication instructions also appear in the <i>EZ Thread Owners Manual</i>.) Pay special attention to the rotator lubrication.
9. Double stitch.	<ol style="list-style-type: none">1. Adjust the stitch clutch according to page 11.2. Check stitch gate timer setting. The gate should stay down until the tail end of the book clears the stitch gate.
10. Booklet folded but not stitched.	<ol style="list-style-type: none">1. Make sure that Stitch on/off switch is in "on" position.2. Check that you are not feeding the books so fast that the gate has not come back up to receive the next book in time.

Stitch'n Fold

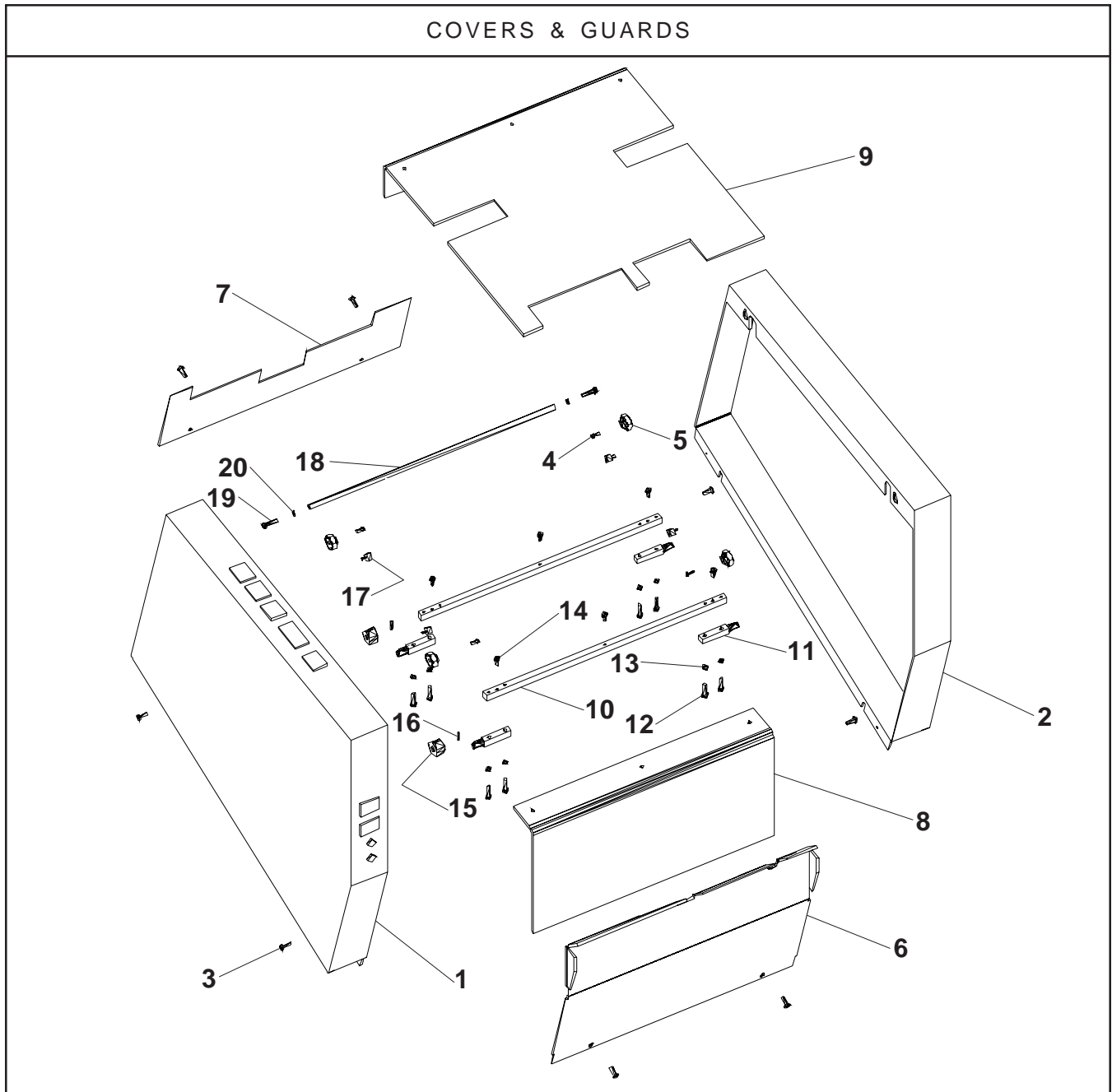

Index Number	Part Number	Part Name	Number Required	Index Number	Part Number	Part Name	Number Required
1	RBM1097F	LH Cover	1	13	CB988	Lockwasher #10	8
2	RBM1098F	RH Cover	1	14	RBM1490F	Tamper-Proof Scr 10-32 x 1/2	6
3	RBM1324F	Pan Hd Scr 10-32 x 1/2	8	15	RBM1274F	Interlock Cam	2
4	RBM1099F	Cover Retaining Stud	4	16	CB835J2	Roll Pin 3/32 x 9/16	2
5	CG26N	Button Hd Scr 8-32 x 3/8	4	17	RBM1316F	Rubber Bumper	4
6	RBM1127F	Front Cover	1	18	RBM1117F	Shaft (Delivery Table Wheels)	1
7	RBM1345F	Back Cover	1	19	CG26A	Button Hd Scr 10-32 x 1/2	2
8	RBM1122F	Front Guard	1	20	CB988	Lockwasher #10	2
9	RBM1121F	Top Guard	1				
10	RBM1276F	Guard Bracket	2				
11	RBM1275F	Guard Hinge	4				
12	CG26C	Button Hd Scr 10-32 x 3/4	8				

FRAME ASSEMBLY

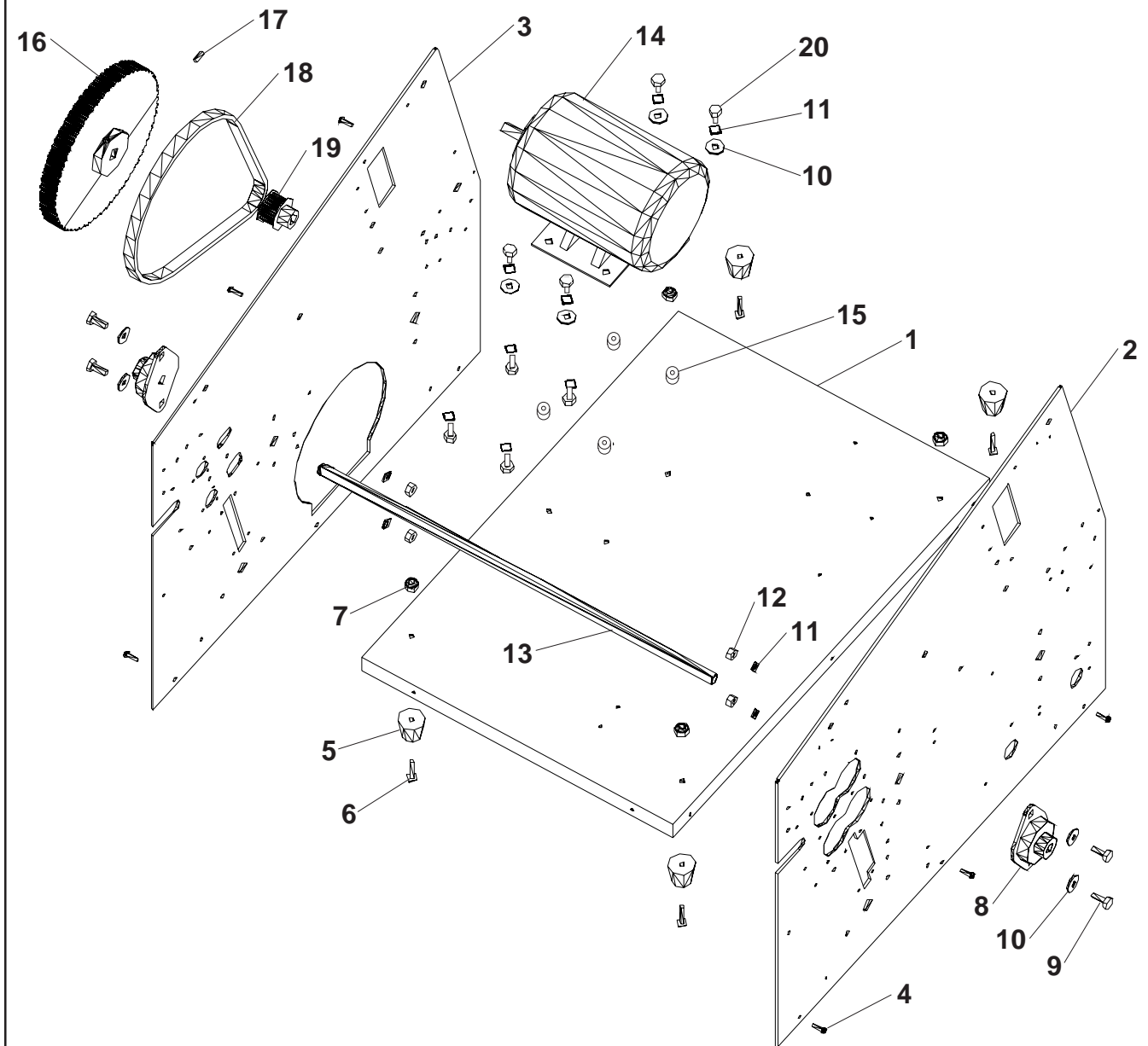

Index Number	Part Number	Part Name	Number Required	Index Number	Part Number	Part Name	Number Required
1	RBM1001F	Frame Bottom	1	12	CB493	Nut 1/4-20	4
2	RBM1006F	LH Side Frame	1	13	RBM1043F	Tape Drive Shaft	1
3	RBM1007F	RH Side Frame	1		CB837E	Retaining Ring	1
4	RBM1324F	Pan Hd Scr 10-32 x 1/2	6		RBM1510F	Collar	1
5	RBM1202F	Bumper Foot	4	14	RBM1347F	Motor	1
6	RBM1252F	Rd Hd Scr 1/4-20 x 1	4	15	RBM1301F	Motor Mount	4
7	CB860C	Elastic Stop Nut 1/4-20	4	16	RBM1046A	Tape Drive Pulley Assy	1
8	RBM1480A	Bearing Assy	2	17	CB59	Set Scr 1/4-20 x 1/2	2
9	CB487A	Hex Hd Scr 1/4-20 x 5/8	4	18	RBM1209F	Motor Belt	1
10	CB718	Washer 1/4	8	19	RBM1356F	Motor Pulley	1
11	RBM1519F	Lockwasher 1/4	12	20	RBM1382F	Hex Hd Scr 1/4-20 x 3/8	8

Stitch'n Fold

HEAD DRIVE ASSEMBLY

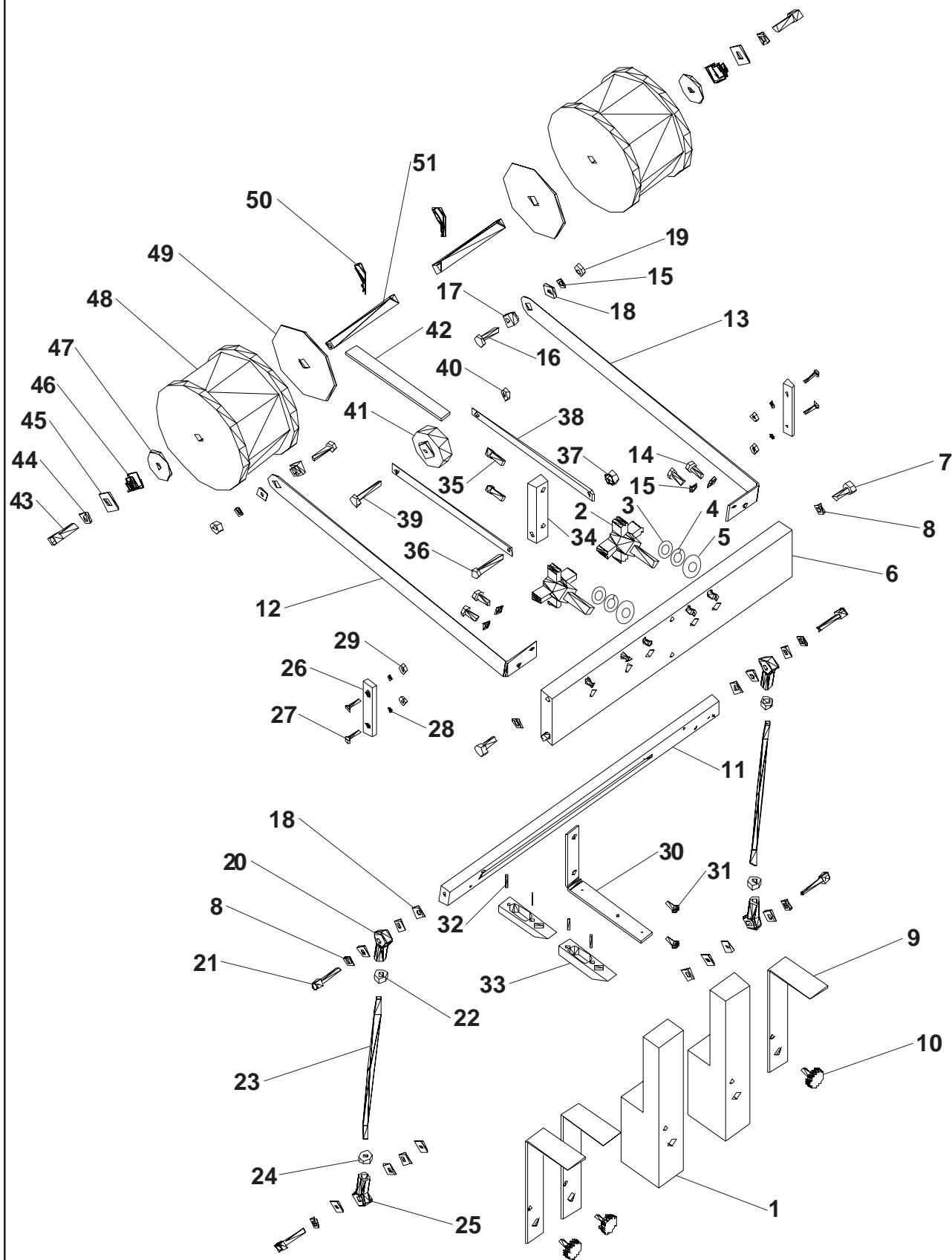

Index Number	Part Number	Part Name	Number Required
1	CAAA2004V	EZ Thread Stitcher Head	2
	CAAA2004U	Conventional Stitcher Head	2
2	RBM1321A	Knob Assy	2
3	CT32A	Thin Washer 1/2	2
4	CB734	Lockwasher 1/2	2
5	CB198	Washer	2
6	RBM1011A	Head Support Bar Assy	1
7	CB606	Hex Hd Scr 5/15-18 x 3/4	2
8	CB895	Lockwasher 5/16	6
9	RBM1315F	Vacant Head Guard	3
10	CGG44B	Knob Assy	3
11	RBM1013A	Head Actuating Bar Assy	1
12	RBM1014F	LH Actuating Bar Bracket	1
13	RBM1015F	RH Actuating Bar Bracket	1
14	CB487A	Hex Hd Scr 1/4-20 x 5/8	4
15	RBM1519F	Lockwasher 1/4	6
16	CB487B	Hex Hd Scr 1/4-20 x 1	2
17	RBM1017F	Pivot Stud	2
18	CB718	Washer	16
19	CB493	Nut 1/4-20	2
20	RBM1220F	RH Rod End	2
21	CB110E	Soc Hd Scr 5/16-24 x 1 1/4	4
22	CB418	RH Nut 5/16-24	2
23	RBM1037F	Head Connecting Rod	2
24	RBM1262F	LH Nut 5/16-24	2
25	RBM1221F	LH Rod End	2
26	RBM1039F	Head Drive Wear Strip	2
27	CB206B	Flat Hd Scr 8-32 x 5/8	4
28	CB988A	Lockwasheer #8	4
29	CB719	Nut 8-32	4
30	RBM1278F	Ski Bracket	1
31	CG26F	Button Hd Scr 1/4-20 x 1/2	2
32	CA9028A	Roll Pin 1/8 x 11/16	4
33	RBM1342F	Paper Ski	2
34	RBM1279F	Roller Bar	1
35	CB51	Soc Hd Scr 1/4-20 x 3/4	2
36	CB764	Hex Hd Scr 1/4-20 x 1 1/2	1
37	CB860C	Elastic Stop Nut 1/4-20	1
38	RBM1280F	Roller Arm	2
39	RBM1361F	Plastic Screw 1/4-20 x 1 1/2	1
40	RBM1362F	Plastic Nut 1/4-20	1
41	CB1247A	Roller	1
42	RBM1344F	Foam Tire	1
43	CB314A	Soc Hd Scr 3/8-16 x 3/4	2
44	RBM1520F	Lockwasheer 3/8	2
45	CA46	Washer	2
46	CK180	Conical Spring	2
47	CA114A	White Plastic Washer	2
48	415-0225	Spool of Stitching Wire	2
49	CA139	Spool Retainer	2
50	CK176	Hairpin	2
51	RBM1290F	Wire Spool Stud	2

Stitch'n Fold

MAIN TABLE ASSEMBLY

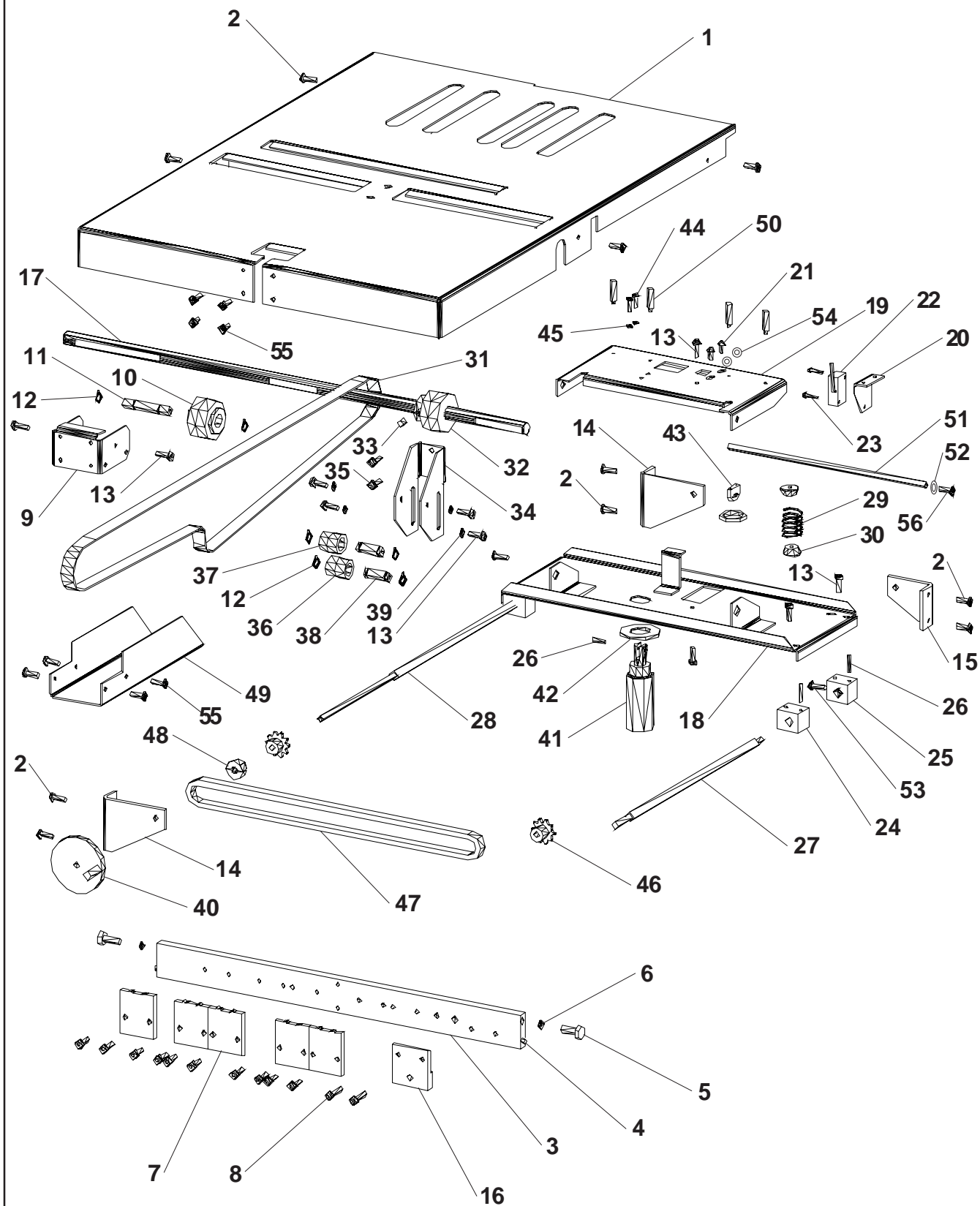

Index Number	Part Number	Part Name	Number Required
1	RBM1004A	Main Table	1
2	RBM1324F	Pan Hd Scr 10-32 x 1/2	10
3	RBM1012F	Clincher Bar	1
4	CB284A	Dowel Pin 3/16 x 3/4	2
5	CB487A	Hex Hd Scr 1/4-20 x 5/8	2
6	RBM1519F	Lockwasher 1/4	2
7	CT9086X	Clincher	5
8	CG26A	Button Hd Scr 10-32 x 1/2	12
9	RBM1019F	Pulley Bracket	1
10	RBM1020F	Table Pulley	1
	RBM1215F	Table Pulley Bearing	2
11	RBM1021F	Pulley Shaft	1
12	CB837B	Retaining Ring 3/8	6
13	CG26	Button Hd Scr 10-32 x 3/8	10
14	RBM1022F	LH Bracket	2
15	RBM1023F	RH Rear Bracket	1
16	RBM1024F	RH Front Bracket	1
17	RBM1043F	Tape Drive Shaft	1
18	RBM1128A	Stop Carriage Assy	1
	RBM1249F	Plastic Bearing	2
19	RBM1049F	Stop Platform	1
20	RBM1052F	Switch Bracket	1
21	CB56M	Soc Hd Scr 8-32 x 1/4	2
22	RBM1310F	Microswitch	1
23	RBM1327F	Rd Hd Scr 4-40 x 1/2	2
24	RBM1055F	RH Front Guide Block	1
25	RBM1056F	RH Rear Guide Block	1
26	CA9028A	Roll Pin 1/8 x 11/16	3
27	RBM1057F	RH Carriage Screw	1
28	RBM1058F	LH Carriage Screw	1
29	RBM1059F	Stop Spring	1
30	RBM1060F	Spring Positioner	2
31	RBM1094F	Table Belt	1
32	RBM1096F	Table Drive Pulley	1
33	CB141	Set Scr 1/4-20 x 1/4	1
34	RBM1100F	Idler Bracket	1
35	CB651	Soc Hd Cap Scr 10-32 x 1/2	2
36	RBM1101A	Crowned Idler	1
	RBM1264F	Idler Bearing	1
37	RBM1340F	Flat Idler	1
	RBM1264F	Idler Bearing	1
38	RBM1102F	Idler Stud	2
39	CB1262	Washer #10	4
40	RBM1224F	Knob	1
41	RBM1234F	Solenoid	1
42	CE17	Washer	1
43	RBM1272F	Solenoid Pivot Bracket	1
44	CB287A	Rd Hd Scr 6-32 x 1/4	2
45	CK50	Lockwasheer #6	2
46	RBM1269F	Sprocket	2
47	RBM1284F	Chain	1
48	RBM1311F	Split Collar	1
	RBM1504F	Spring	1
49	RBM1302F	Belt Guard	1
50	RBM1309A	Book Stop Assy	4
51	RBM1313F	Gate Shaft	1
52	CB988A	Lockwasher #8	2
53	CB651F	Soc Hd Cap Scr 10-32 x 3/8	2
54	D31029F	Washer #8	2
55	RBM1323F	Pan Hd Scr 8-32 x 1/2	8
56	CG26N	Button Hd Scr 8-32 x 3/8	2

Stitch'n Fold

HEAD DRIVE SHAFT ASSEMBLY

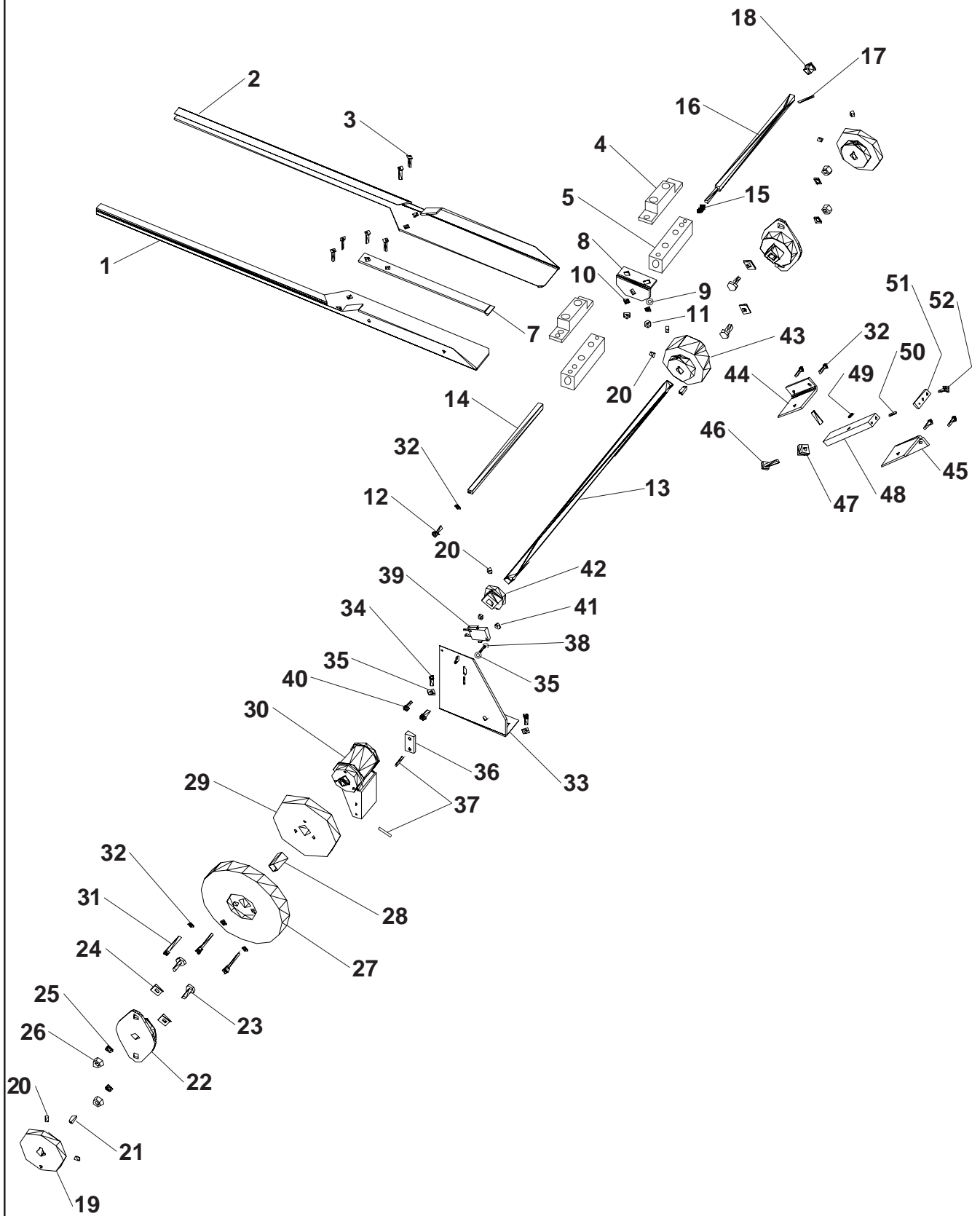

Index Number	Part Number	Part Name	Number Required
1	RBM1088F	LH Side Guide	1
2	RBM1089F	RH Side Guide	1
3	RBM1329F	Flat Hd Scr 8-32 x 5/8	6
4	RBM1081F	Spacer	2
5	RBM1080F	Side Guide Bracket	2
6	CB56M	Soc Hd Scr 8-32 x 1/4	4
7	RBM1343F	Belt Bed	1
8	RBM1082F	Guide Shaft Support	1
9		Washer #8	2
10	CB988A	Lockwasher #8	2
11	CB719	Nut 8-32	2
12	CG26A	Button Hd Scr 10-32 x 1/2	1
13	RBM1042F	Head Drive Shaft	1
	CB837E	Retaining Ring	1
	RBM1510F	Collar	1
14	RBM1078F	Stationary Guide Shaft	1
15	RBM1229F	Spring	1
16	RBM1079F	Moveable Guide Shaft	1
17	CB835G	Roll Pin	1
18	RBM1250F	Plastic Bearing	1
19	RBM1038F	Head Drive Crank	2
20	CB141	Set Screw 1/4-20 x 1/4	7
21	RBM1242F	Woodruff Key	2
22	RBM1480A	Bearing Assy	2
23	CB487A	Hex Hd Scr 1/4-20 x 5/8	4
24	CB718	Washer 1/4	4
25	RBM1519F	Lockwasher 1/4	4
26	CB493	Nut 1/4-20	4
27	RBM1047F	Head Drive Pulley	1
28	RBM1254F	Bearing	1
29	RBM1297F	Knife Drive Pulley	1
30	RBM1227F	Clutch	1
31	MF337	Soc Hd Scr 10-32 x 1 1/2	3
32	CB988	Lockwasher #10	4
33	RBM1125F	Switch & Clutch Bracket	1
34	RBM1224F	Pan Hd Scr 10-32 x 1/2	6
35	CB1262	Washer #10	3
36	RBM1265F	Clutch Pin Block	1
37	CA9028A	Roll Pin	2
38	CB651F	Soc Hd Scr 10-32 x 3/8	1
39	RBM1225F	Cam Microwitch	1
40	RBM1328F	Rd Hd Scr 4-40 x 3/4	2
41	CG13	Nut 4-40	2
42	RBM1126F	Switch Cam	1
43	RBM1092F	Actuator Cam	1
44	RBM1091F	LH Bracket	1
45	RBM1090F	RH Bracket	1
46	RBM1086F	Roller Stud	1
47	RBM1085F	Roller	1
48	RBM1084F	Actuator Bar	1
49	D22872F	Set Scr 10-32 x 1/4	1
50	CB835P	Roll Pin	1
51	RBM1087F	Actuator Bar Extension	1
52	CG26	Button Hd Scr 10-32 x 3/8	1

Stitch'n Fold

ROLLERS & KNIFE ASSEMBLY

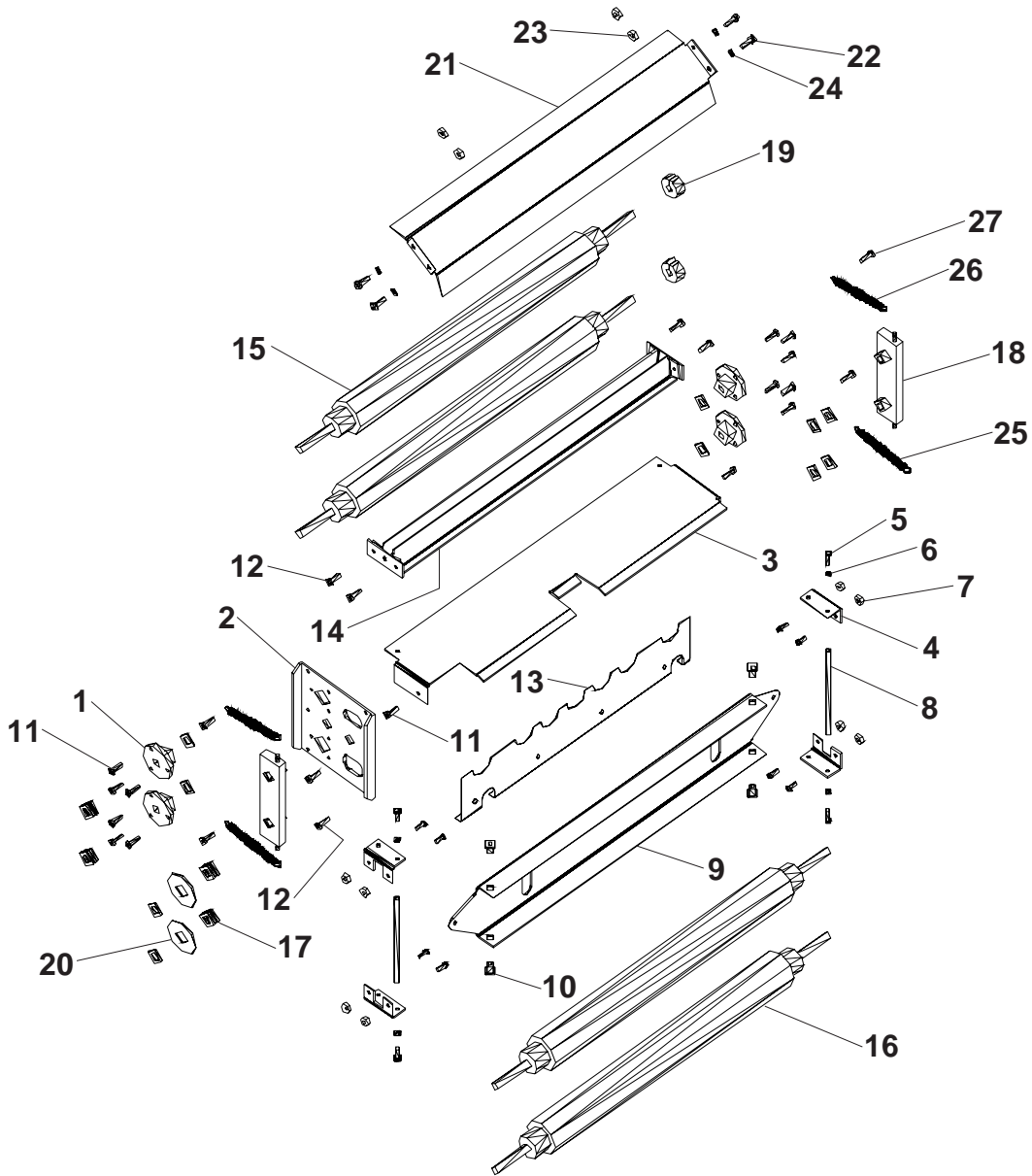

Index Number	Part Number	Part Name	Number Required	Index Number	Part Number	Part Name	Number Required
1	RBM1505A	Bearing Block Assy	2	15	RBM1064A	Upper Folding Roll Assy	2
2	RBM1010F	Folder Retaining Plate	1	16	RBM1065A	Lower Folding Roll Assy	2
3	RBM1018F	Spacer Table	1	17	CB2125	Nylon Washer 7/16 (3/4 O.D.)	30
4	RBM1025F	Knife Guide Bracket	4	18	RBM1130A	Bearing Block Assy	4
5	CG26N	Button Hd Scr 8-32 x 3/8	12	19	RBM1312F	Split Collar	2
6	CB988A	Lockwasher #8	12	20	CA114A	Teflon Washer 5/8 (1 1/2 O.D.)	2
7	CB719	Nut 8-32	8	21	RBM1123F	Book Deflector	1
8	RBM1028F	Knife Guide Rod	2	22	CG26A	Button Hd Scr 10-32 x 1/2	4
9	RBM1034A	Knife Support Assy	1	23	CB278	Nut 10-32	4
10	RBM1249F	Plastic Bearing	4	24	CB988	Lockwasher #10	2
11	RBM1323F	Pan Hd Scr 8-32 x 1/2	10	25	RBM1232F	Lower Roll Spring	2
12	RBM1324F	Pan Hd Scr 10-32 x 1/2	10	26	RBM1314F	Upper Roll Spring	2
13	RBM1035F	Folding Knife	1	27	CG26C	Button Hd Scr 10-32 x 3/4	4
	CB651F	Soc Hd Scr 10-32 x 3/8	4		CB278	Nut 10-32	8
14	RBM1063A	Book Guide Assy	1		CB988	Lockwasher #10	4

KNIFE SHAFT ASSEMBLY

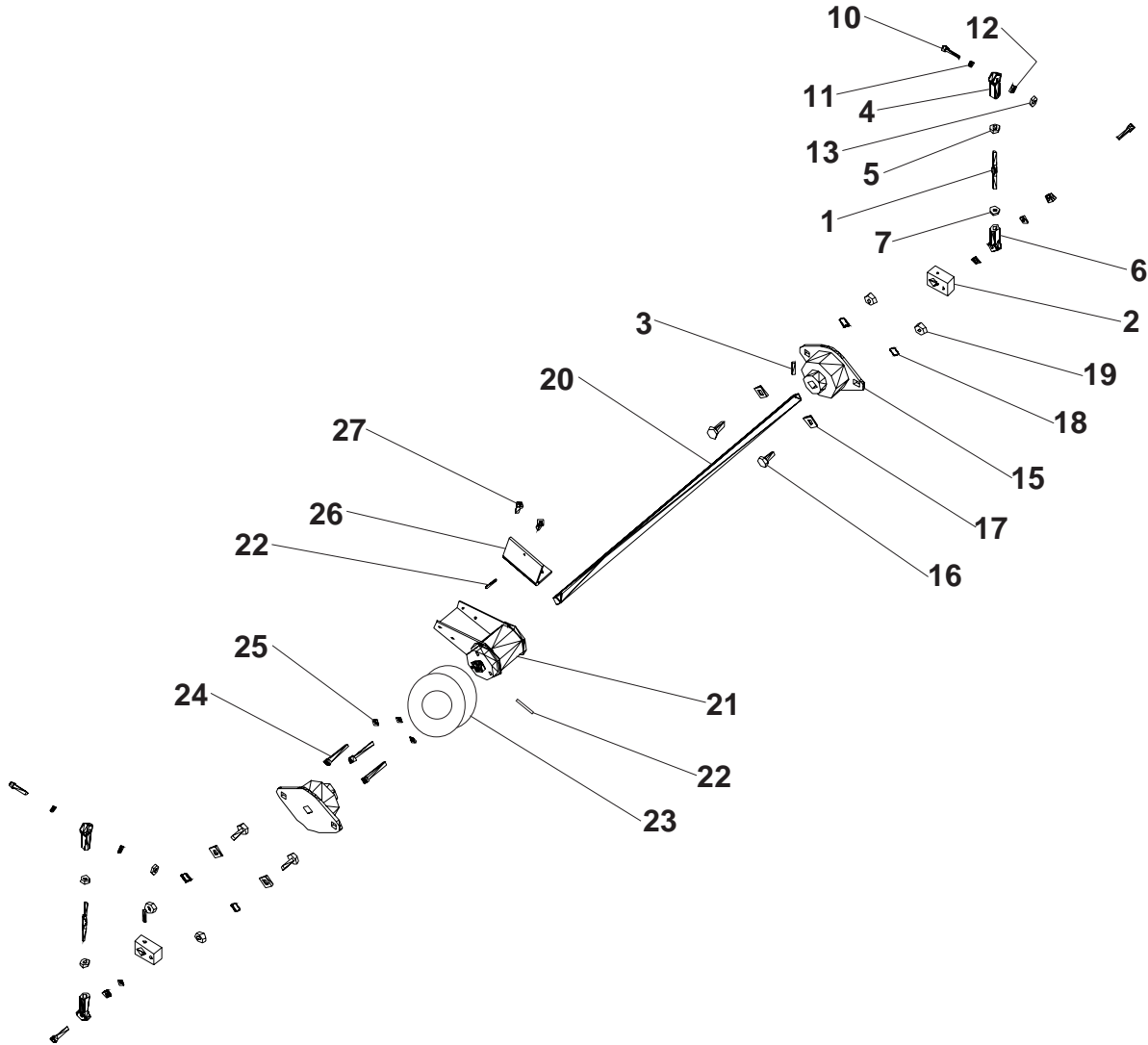

Index Number	Part Number	Part Name	Number Required	Index Number	Part Number	Part Name	Number Required
1	RBM1036F	Knife Connection Rod	2	17	CB718	Washer	4
2	RBM1040F	Knife Drive Crank	2	18	RBM1519F	Lockwasher 1/4	4
3	CA9028A	Roll Pin 1/8 x 11/16	2	19	CB493	Nut 1/4-20	4
4	RBM1222F	RH Rod End	2	20	RBM1041F	Knife Drive Shaft	1
5	CB278	RH Nut 10-32	2		CB837E	Retaining Ring	1
6	RBM1223F	LH Rod End	2		RBM1510F	Collar	1
7	RBM1263F	LH Nut 10-32	2	21	RBM1227F	Clutch	1
10	CB651B	Soc Hd Scr 10-32 x 3/4	4	22	CA9028A	Roll Pin 1/8 x 11/16	2
11	CB988	Lockwasher #10	4	23	RBM1206A	Pulley Assy	1
12	CB1262	Washer #10	8	24	MF337	Soc Hd Scr 10-32 x 1 1/2	3
13	CB278	Nut 10-32	2	25	CB988	Lockwasher #10	3
15	RBM1480A	Bearing Assy	2	26	RBM1300F	Knife Clutch Bracket	1
16	CB487A	Hex Hd Scr 1/4-20 x 5/8	4	27	RBM1324F	Pan Hd Scr 10-32 x 1/2	2

Stitch'n Fold

BELTS & CHAINS ASSEMBLY

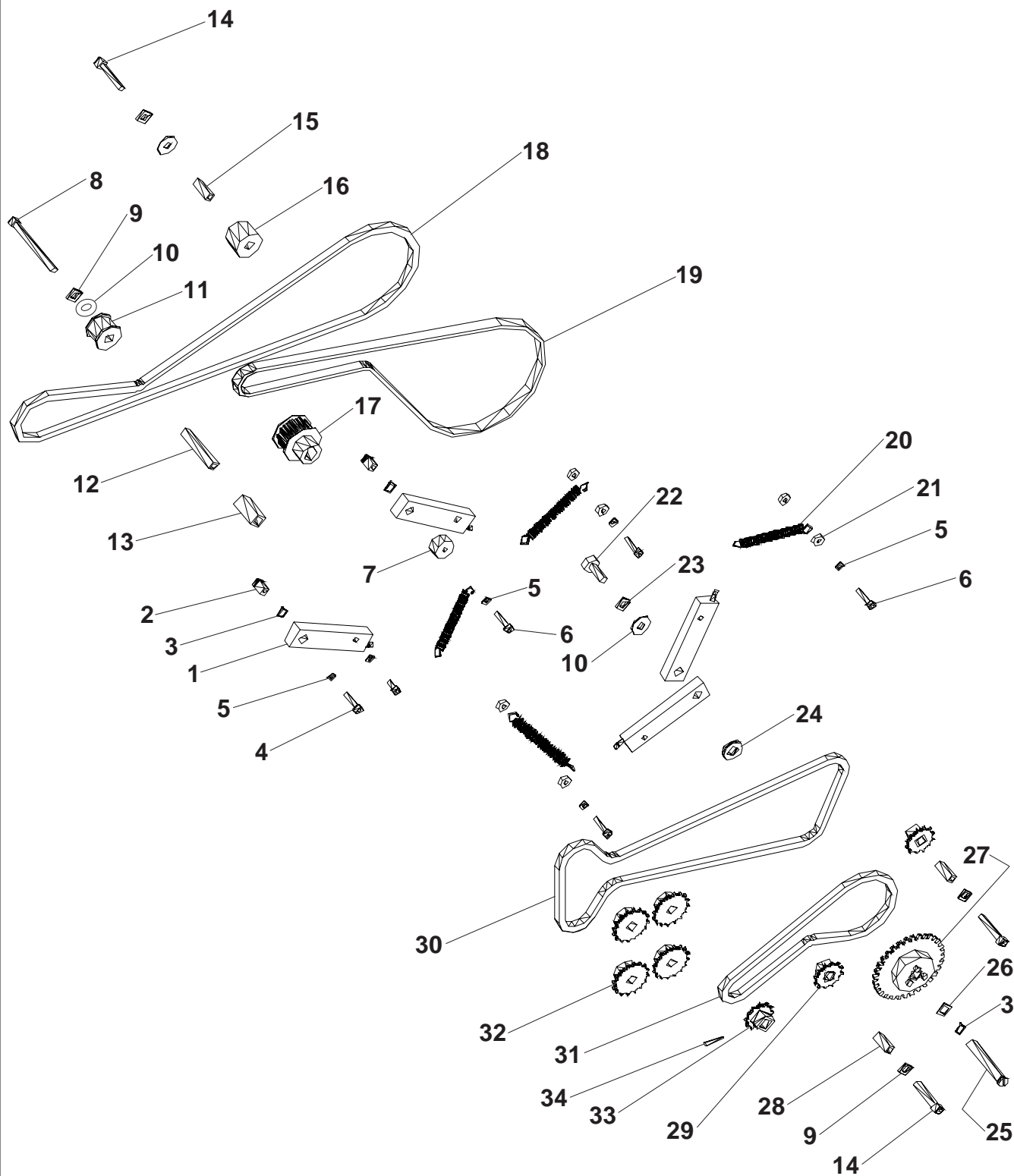

Index Number	Part Number	Part Name	Number Required
1	RBM1044A	Idler Bracket Assy	4
2	RBM1045F	Idler Bracket Stud	2
3	CB837B	Retaining Ring 3/8	3
4	CG26	Button Hd Scr 10-32 x 3/8	1
5	CB988	Lockwasher #10	6
6	CG26C	Button Hd Scr 10-32 x 3/4	5
7	RBM1292F	Idler Spacer	1
8	D44958F	Soc Hd Scr 1/4-20 x 2 1/2	1
9	RBM1519F	Lockwasher 1/4	4
10	CB718	Washer	3
11	RBM1360F	Idler Roll	1
12	RBM1294F	Knife Idler Shaft	1
13	RBM1295F	Idler Spacer	1
14	CB629B	Soc Hd Scr 1/4-20 x 1 1/4	3
15	RBM1293F	Stitcher Idler Shaft	1
16	RBM1291F	Idler Roll	1
17	RBM1207F	Reducer Pulley 10 Teeth	1
18	RBM1210F	Timing Belt 1/2" Wide	1
19	RBM1211F	Timing Belt 3/8" Wide	1
20	RBM1231F	Idler Spring	4
21	CB278	Nut 10-32	8
22	CB606	Hex Hd Scr 5/16-18 x 3/4	1
23	CB895	Lockwasher 5/16	1
24	CB2125	Nylon Washer 7/16 (3/4 O.D.)	2
25	RBM1288F	Sprocket Stud	1
26	CT32	Washer	1
27	RBM1286A	Dual Sprocket Assy	1
28	RBM11289F	Idler Stud	2
29	RBM1218A	Idler Sprocket Assy	2
30	RBM1219F	Long Chain	1
31	RBM1270F	Short Chain	1
32	RBM1216F	Folding Roll Sprocket	4
	RBM1399F	Set Screw 5/16-18 x 5/16	4
33	RBM1217F	Drive Sprocket	1
34	CA9028A	Roll Pin 1/8 x 11/16	1
35*	RBM1432A	8T Sprocket (to Folding Roll)	1
36*	RBM1430F	32T Sprocket (to Conveyor)	1
37*	RBM1399F	Set Screw	2
38*	RBM1437A	12T/32T Double Sprocket	1
39*	RBM1218A	12T Idler Sprocket	1
40*	RBM1448F	Chain 18.5"	1
41*	RBM1449F	Chain 17.0"	1
42*	RBM1438F	Shaft	2
43*	CB328	Hex Hd Scr 3/8-16 x 5/8	2
44*	CB179	Washer	2
45*	RBM1520F	Lockwasher 3/8	2
	*	Not shown	

Stitch'n Fold

SECONDARY TABLE ASSEMBLY

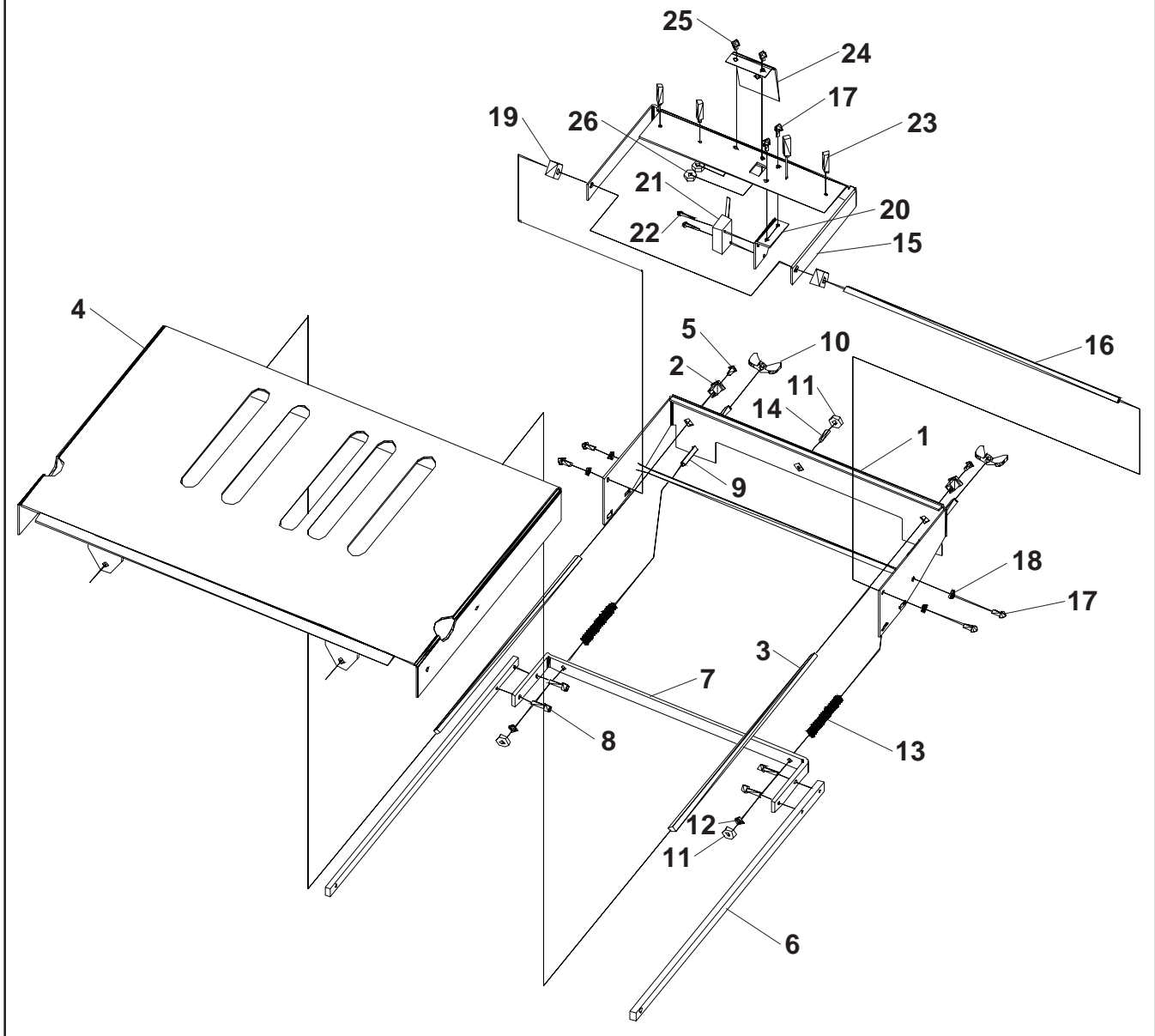

Index Number	Part Number	Part Name	Number Required	Index Number	Part Number	Part Name	Number Required
1	RBM1129A	Rear Stop Assy	1	15	RBM1033F	Rear Stop Support	1
2	RBM1249F	Plastic Bearing	2	16	RBM1031F	Rear Stop Shaft	2
3	RBM1027F	Guide Rod	2	17	CB112	Rd Hd Scr 8-32 x 5/16	6
4	RBM1005A	Secondary Table	1	18	CB988A	Lockwasher #10	4
5	CG26N	Button Hd Scr 8-32 x 3/8	2	19	RBM1311F	Split Collar	2
6	RBM1032F	Rear Stop Connecting Link	2	20	RBM1052F	Switch Bracket	1
7	RBM1303F	Stud Bracket	1	21	RBM1310F	Micro Switch	1
8	D30523F	Soc Hd Cap Scr 8-32 x 1/2	4	22	RBM1327F	Rd Hd Scr 4-40 x 1/2	2
9	RBM1304F	Adjusting Stud	2	23	RBM1309A	Stop Assy	4
10	RBM1308F	Wing Nut 10-32	2	24	RBM1133F	Latch	1
11	CB278	Nut 10-32	3	25	CB70	Rd Hd Scr 8-32 x 3/16	2
12	CB988	Lockwasher #10	2	26	CB719	Nut 8-32	2
13	RBM1305F	Spring	2	27*	RBM1381F	Sensor Guard	1
14	CB722A	Set Scr 10-32 x 1/2	1	28*	RBM1324F	Pan Hd Scr 10-32 x 1/2	4

* Not shown

DELIVERY TABLE ASSEMBLY

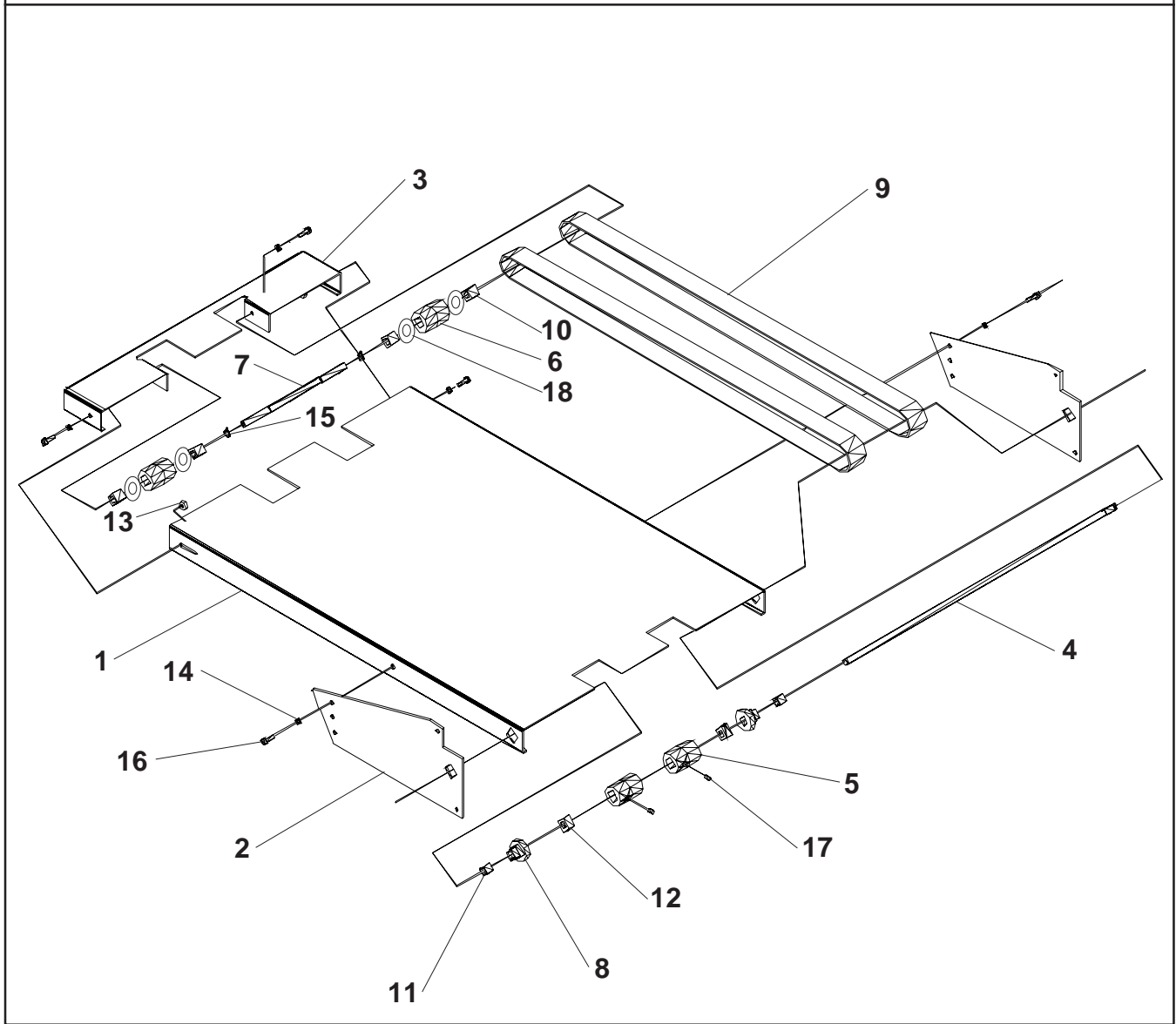

Index Number	Part Number	Part Name	Number Required	Index Number	Part Number	Part Name	Number Required
1	RBM1447F	Delivery Table	1	18	CB2125	Nylon Washer	4
2	RBM1069F	Mounting Bracket	2	19*	RBM1415F	Booklet Stacker	1
3	RBM1446A	Delivery Tray	1	20*	RBM1438A	Stud /Knob Assy	1
4	RBM1450F	Drive Shaft	1	21*	CT32A	Thin Washer 1/2	1
5	RBM1072F	Drive Pulley	2	22*	CB734	Lockwasher 1/2	1
6	RBM1073F	Idler Pulley	2	23*	CB198	Washer 1/2	1
7	RBM1074F	Idler Shaft	1	24*	RBM1426F	Wheel	2
8	RBM1075F	Bearing Block	2	25*	RBM1412F	Wheel Shaft	1
9	RBM1425F	Delivery Belt	2	26*	RBM1426F	Wheel	2
10	RBM1214F	Bronze Bearing	4	27*	CGG44	Thumb Screw	1
11	RBM1215F	Bronze Bearing	2	28*	RBM1413F	Wheel Rod	1
12	RBM1258F	Shaft Collar	2	29*	RBM1414F	Cross Bracket	1
13	CB278	Nut 10-32	4	30*	D37769F	Roll Pin 1/8 x 1/2	1
14	CB988	Lockwasher #10	6	31*	CB837B	Retaining Ring 3/8	2
15	CB837B	Retaining Ring	2	32*	CB837R	Retaining Ring 1/2	4
16	CG26A	Button Hd Scr 10-32 x 1/2	6	33*	RBM1380F	Roller Discharge Guard	1
17	D22872F	Set Scr 10-32 x 1/4	2	34*	RBM1324F	Pan Hd Scr 10-32 x 1/2	4

* Not shown

Stitch'n Fold

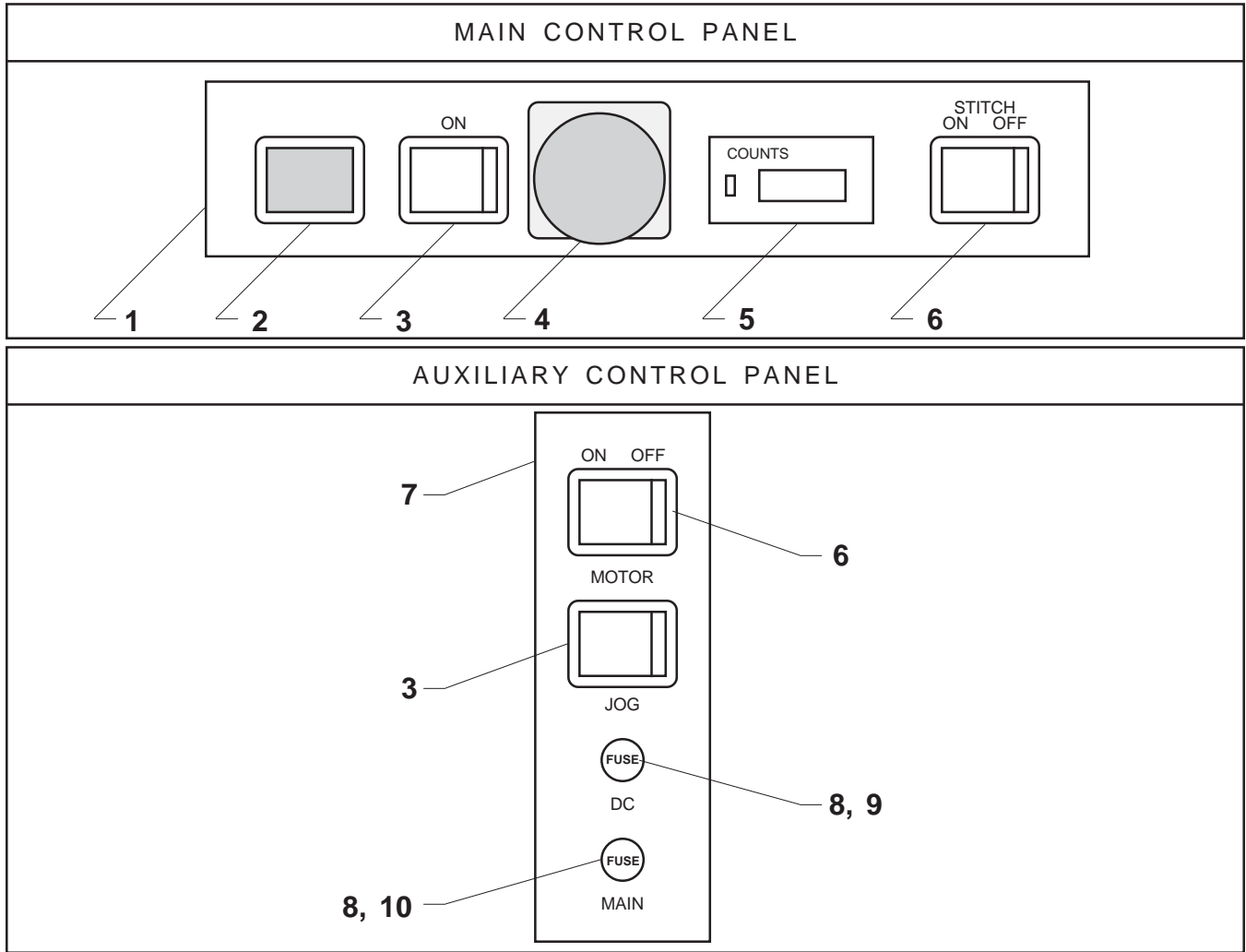

Index Number	Part Number	Part Name	Number Required	Index Number	Part Number	Part Name	Number Required
1	RBM1335F	Main Control Panel Decal	1	23*	RBM1429F	Rubber Grommet	1
2	RBM1348F	Pilot Light	1	24*	RBM1277F	Interlock Switch (1LS, 2LS)	2
3	CG137	Black Momentary Switch	2	25*	RBM1225F	Micro Switch (3LS)	1
4	RBM1491F	Emergency Stop	1	26*	RBM1310F	Micro Switch (4LS, 5LS)	2
	RBM1492F	Contact Block	1	27*	RBM1317F	Relay Bracket	1
	RBM1493F	Yellow Plate	2	28*	RBM1324F	Pan Hd Scr 10-32 x 1/2	2
5	RBM1445F	Counter	1	29*	RBM1355F	Power Relay (1CR)	1
6	CG138	Black Selector Switch	2	30*	CB650	Rd Hd Scr 6-32 x 1	4
7	RBM1336F	Auxiliary Control Panel Decal	1	31*	CB720	Nut 6-32	4
8	RBM1349F	Fuse Holder	2	32*	RBM1416F	Timer - Single Shot	1
9	RBM1350F	Fuse	1	33*	RBM1417F	Timer Socket	1
10	RBM1352F	Fuse	1	34*	RBM1418F	Timer Potentiometer	1
11*	RBM1354F	Power Cord (Continental Eur.)	1	35*	RBM1419F	Potentiometer Knob	1
12*	RBM1266F	Power Cord Bracket	1	36*	RBM1452F	Gate Timer Decal	1
13*	RBM1323F	Pan Hd Scr 8-32 x 1/2	2	37*	CB287E	Rd Hd Scr 6-32 x 1/2	2
14*	RBM1495F	Power Inlet	1	38*	CB720	Nut	2
15*	CB808	Flat Hd Scr 5-40 x 3/8	2	39*	RBM1299F	Transformer	1
16*	D27398F	Elastic Stop Nut	2	40*	RBM1323F	Pan Hd Scr 8-32 x 1/2	2
17*	RBM1240F	Terminal Block	2	41*	RBM1298F	Rectifier	1
18*	D32127F	Rd Hd Scr 6-32 x 3/4	4	42*	RBM1324F	Pan Hd Scr 10-32 x 1/2	1
19*	CB720	Nut 6-32	4	43*	RBM1234F	Gate Solenoid	1
20*	RBM1347F	Motor	1	44*	RBM1227F	Clutch (Stitch, Fold)	2
21*	CB1070B	Green Ground Screw	2	45*	RBM1443F	Quencharc	1
22*	RBM1428F	Rubber Grommet	5	46*	RBM1494F	Line Filter	1

* Not shown; see Schematic.

ELECTRICAL SCHEMATIC

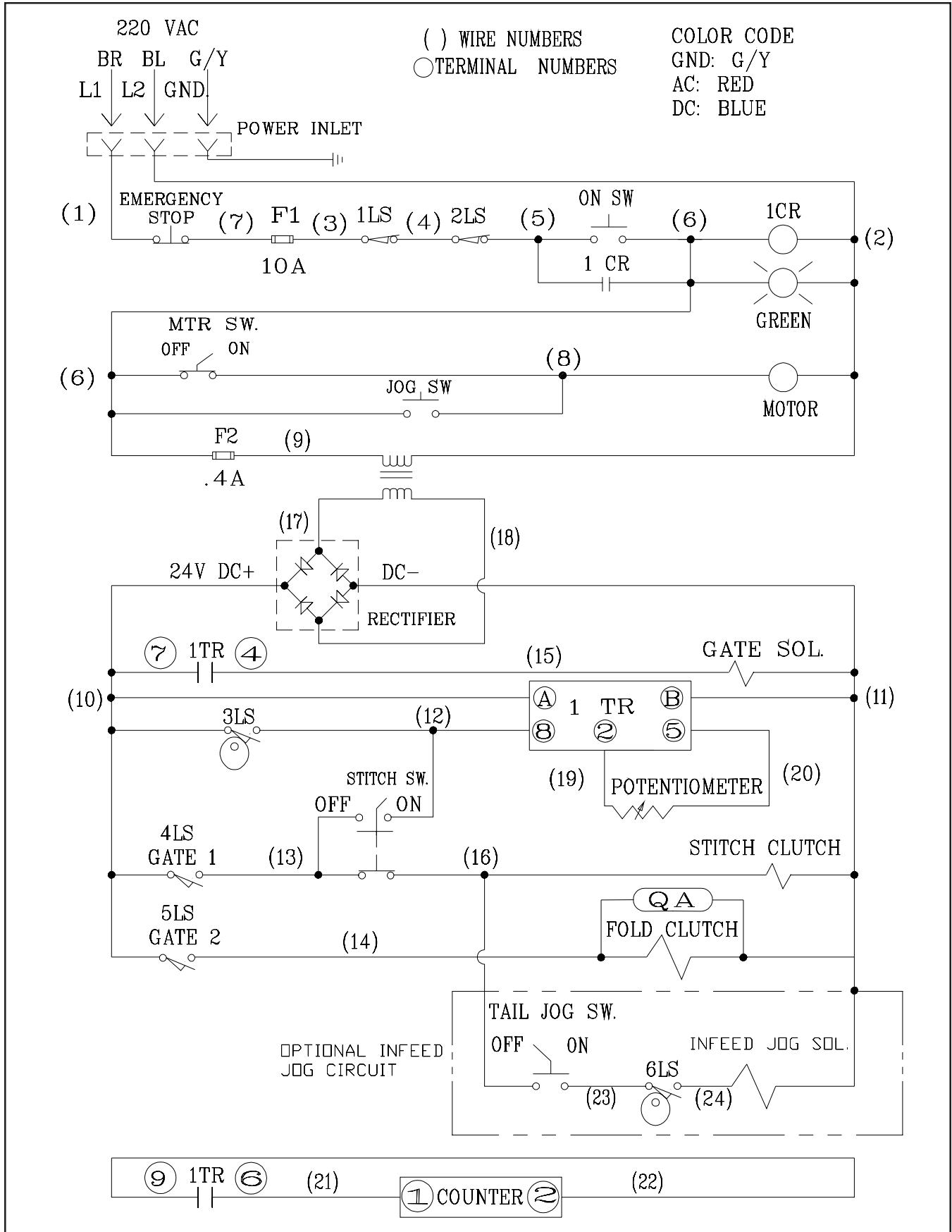

ISP **Stitching & Bindery Products**

A Division Of Samuel Strapping Systems

USA:

718 Marquette Street Racine, WI 53403

1-800-345-6641 1-414-632-5115

Fax: 1-414-632-9240

OUTSIDE USA:

6843 Santa Fe Drive Hodgkins, IL 60525

1-708-482-9500

Fax: 1-708-482-0274