



COMPANY INC.  
**ISP** **Stitching & Bindery Products**

*solving your wire stitching needs for 125 years...*

Machine Serial Number : \_\_\_\_\_

Head Serial Numbers : \_\_\_\_\_

Date Purchased : \_\_\_\_\_

# Model M17 Stitcher

## OPERATION AND MAINTENANCE MANUAL

M17-AST Stitcher.....with 26D Head.....115V and 60HZ  
M17-BST Stitcher.....with 26D Head.....230V and 50HZ  
M17G8-AST Stitcher.....with G8 Head.....115V and 60HZ  
M17G8-BST Stitcher.....with G8 Head.....230V and 50HZ

**Before using this Stitcher, all operators must study this manual and follow the safety warnings and instructions. Keep these instructions with the M17 Stitcher Head for future reference. If you have any questions, contact your local DeLuxe Stitcher Graphic Arts Representative or Distributor.**



# **TABLE OF CONTENTS**

<b><u>SECTION</u></b>	<b><u>DESCRIPTION</u></b>	<b><u>PAGE</u></b>
1	INTRODUCTION	4
2	INSTALLATION	6
	2.1 Belt Guard Removal and Assembly	6
	2.2 Turning Machine Manually	7
3	OPERATING ADJUSTMENTS	7
	3.1 Adjusting the Machine for Thickness of Work	7
	3.2 Raising or Lowering the Clinchers	9
4	MAINTENANCE	10
	4.1 Lubrication	10
5	M17 DIAGRAM & PARTS LIST	11
6	CLUTCH-BRAKE MAINTENANCE	17
	6.1 Actuator	17
	6.2 Clutch and Brake Springs	18
	6.3 Disassembly	19
	6.4 Assembly	19
	6.5 Lubrication	21
	6.6 Coil Replacement	21
	6.7 Control Collar Adjustment	21
7	DECLARATION of CONFORMITY	22
8	WARRANTY AND SERVICE INFORMATION	24

## **1.0 INTRODUCTION**

The Deluxe Stitcher M17 Book Stitcher is a combination light & heavy duty stitcher designed to staple both flat and saddle work ranging in thickness from a few sheets to 5/16 (8mm). The stitcher is equipped with two heads standard, but can be operated with as many as ten 26D heads or eight G8 heads installed at one time. Maximum center to center distance is 16" (40.5 cm), minimum is approximately 1-7/8" (48mm).

The recommended wire sizes to be used on the M17 are as follows: Round wire - 25 to 30 for the 26D head, 24 to 28 for the G8 head. Either head can be equipped with optional 21 x 25 wire parts.

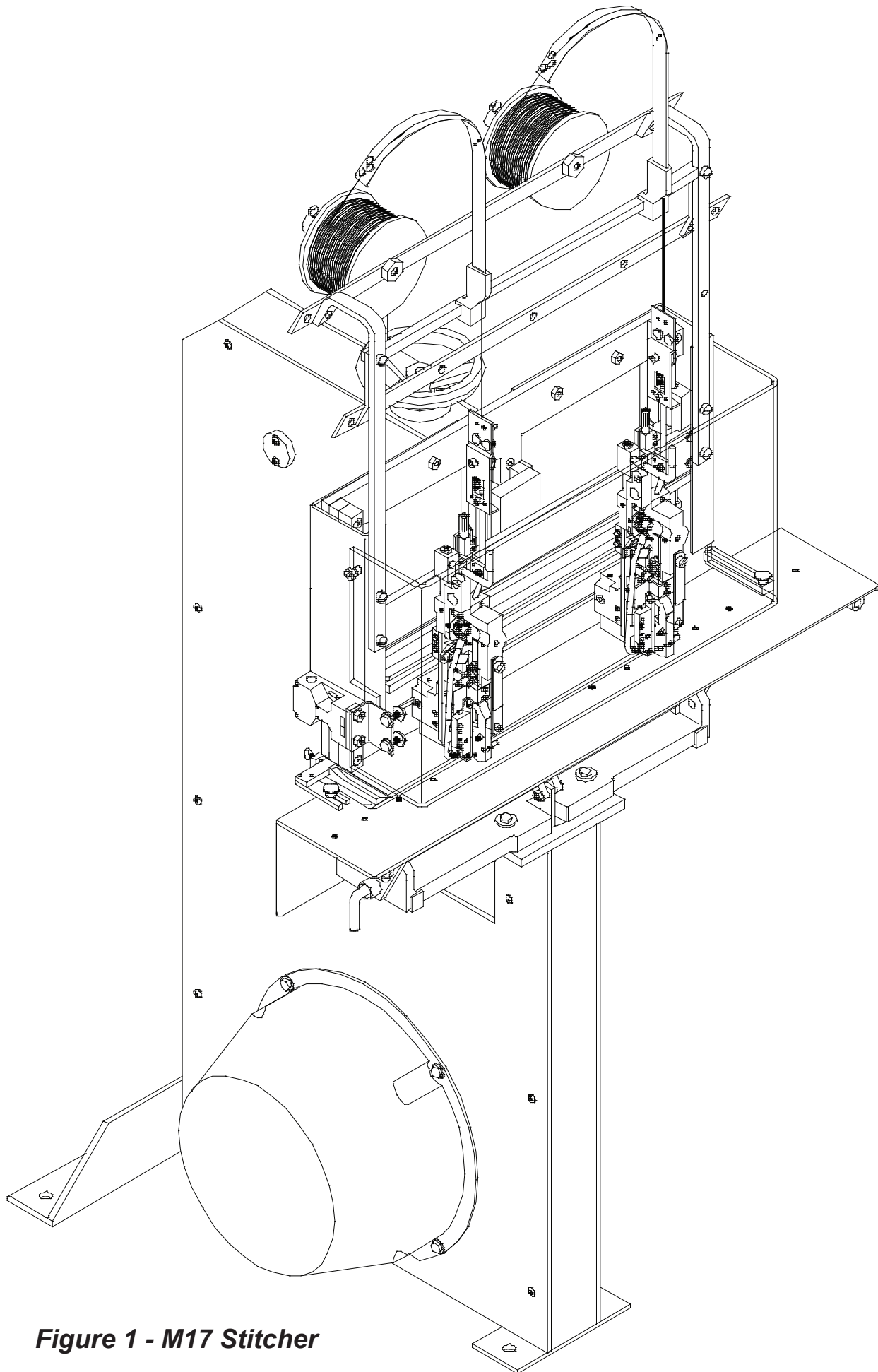
The M17 is easily adjusted from saddle work to flat work by means of tilting the 6 1/2" (16.5cm) x 33" (83.8cm) work table. An adjustable work guide and adjustable work stops are easily attached to the work table and provide for accurate registering of flat work for uniform spacing of staples.

The M17 is footswitch operated and is belt driven by a 3/4 HP motor, making possible operating speeds up to 200 stitches per minute. The motor is mounted on an adjustable bracket which can be raised or lowered for adjusting the driving belt tension. The machine driving mechanism is thoroughly shielded thus preventing the possibility of personal injury.

The M17 has a 14" (35.6cm) throat depth for both flat and saddle stitching. The work table is approximately 34" (86.4cm) above the floor, and there is approximately 17/32" (13.5mm) clearance between the top of the work table and the stitching head.

The M17 weighs approximately 445 lbs. (202 kgs) net, shipping weight is approximately 500 lbs. (227 kgs). With the table installed, the M17 requires about 33" (83.8cm) x 30" (76.2cm) of floor space.

Because of the length of the work table, the M17 must be secured to the floor to meet CE stability requirements. Sound level readings at the normal operator position are approximately 70 dBC.



**Figure 1 - M17 Stitcher**

## 2.0 INSTALLATION


The M17 is a free standing, floor mounted, wire stitcher. The following parts must be assembled after shipment: work table, spool bar brackets, spool bars, spool studs, wire spools, adjuster hand-wheel handle, and wire guide springs. The M17 can be lagged to the floor, if desired, after leveling.

Refer to the Operation Manual for the stitcher heads for instructions on how to attach the heads to the machine. As each successive head is installed, the machine should be turned over by hand (see instructions below).

Slide the stitching head(s) and clincher(s) to the desired location on the mounting rail. Place a spool of the proper sized wire on the spool studs located near the appropriate head. Thread the wire onto the head and make adjustments to wire length & straightness as described in the head Operation Manual.

Electrical power is provided through the attached line cord to be connected to an appropriate supply outlet rated as shown:

SUPPLY POWER	115 V / 60 HZ	230 V / 50 HZ
M17 RATED CURRENT	12 A	6.4 A
M17 INTERRUPT CURRENT, INTERNAL BREAKER	12 kA	12 kA

 **WARNING** DO NOT OPERATE THE M17 UNDER POWER UNTIL THE MACHINE HAS BEEN TURNED OVER MANUALLY (SEE BELOW) TO VERIFY THAT THE STITCHING HEADS ARE OPERATING FREELY.

### 2.1 BELT GUARD REMOVAL AND ASSEMBLY

 **WARNING** ALWAYS DISCONNECT THE POWER SUPPLY BEFORE MAKING ANY ADJUSTMENTS OR SERVICING THE STITCHER.

The plastic belt guard must first be removed before the M17 can be turned over manually. To remove the belt guard, remove the retaining screws from the guard if provided. Press on one side tab while prying out the locking face. This will release the first tab. Next, pull down slightly on the top of the guard to release the bottom tab. Guard will now be free to lift off remaining tabs on mounting plate.

To reassemble, interlock the top tab and one side tab. Pull down slightly on top of guard to interlock bottom tab, then squeeze mounting plate and guard together to lock remaining tab, completing assembly. Reassemble the retaining screws of the guard if provided.

## 2.2 TURNING MACHINE MANUALLY

 **WARNING** ALWAYS DISCONNECT THE POWER SUPPLY BEFORE MAKING ANY ADJUSTMENTS OR SERVICING THE STITCHER.

To turn the machine manually, it is necessary to first disconnect the power and remove the belt guard (see above). Locate the actuator assembly on the wrap spring clutch and push the actuator to pivot it away from the control collar cam, releasing the brake. The machine will rotate one revolution when the large drive pulley is turned manually in the direction of the arrow on the pulley (top of pulley toward front of machine).

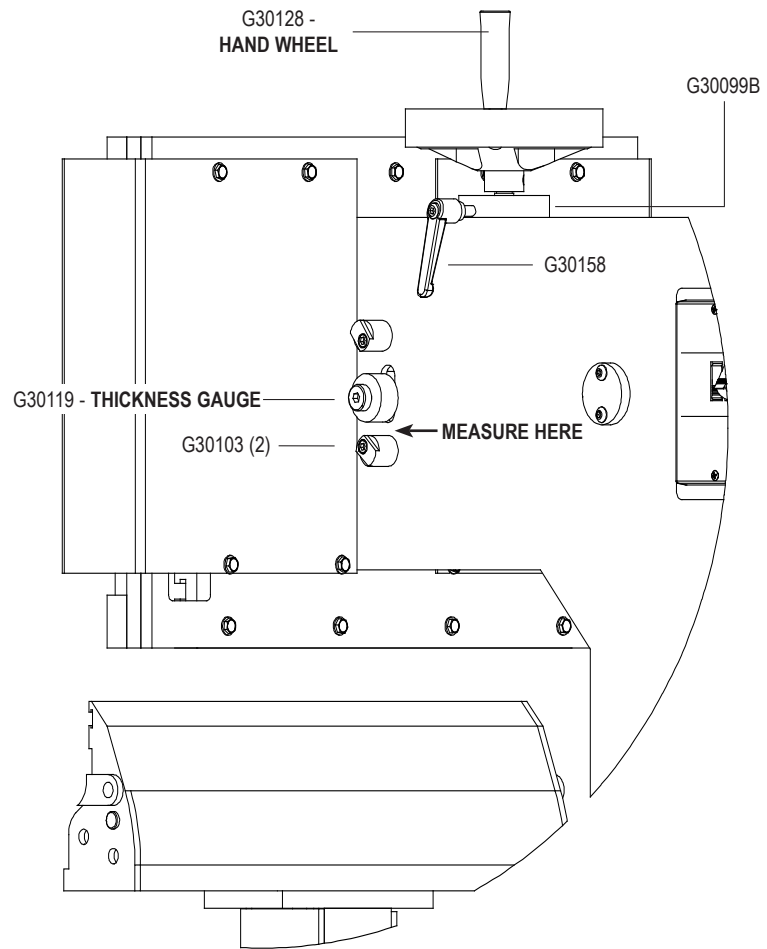
## 3.0 OPERATING ADJUSTMENTS

The quality and quantity of work that can be stitched on the M17 is dependent upon the operator making the various operating adjustments as accurately as possible. The following information and instructions are provided so that the operator will clearly understand how to make the required operating adjustments.

### 3.1 ADJUSTING THE MACHINE FOR THICKNESS OF WORK (See Figure 2)

Unlock the Hand Wheel (G30128) by turning the Adjuster Crank Lock (G30158) on the Adjuster Crank Housing (G30099B) counter-clockwise. Turn the Hand Wheel clockwise until the Thickness Gauge (G30119) is raised sufficiently to allow a sample of work to be inserted between it and the lower Adjuster Stop (G30103).

The thickness gauge is located on the right-hand side of the machine if you are looking from the front of the stitcher. With the work held flat in a horizontal position, turn the Hand Wheel counter-clockwise until the work is firmly clamped between the Thickness Gauge and the lower Adjuster Stop. Turn the Hand Wheel back clockwise just enough to allow the work to be withdrawn from the Thickness Gauge, then return the Hand Wheel to the setting at which the work was clamped.



***Figure 2 - Work Thickness Adjustment***

**CAUTION: IF THE MACHINE IS OPERATED ON WORK THICKER THAN IT IS SET TO HANDLE, DAMAGE WILL RESULT AND THE STITCHER WILL NOT OPERATE PROPERLY.**



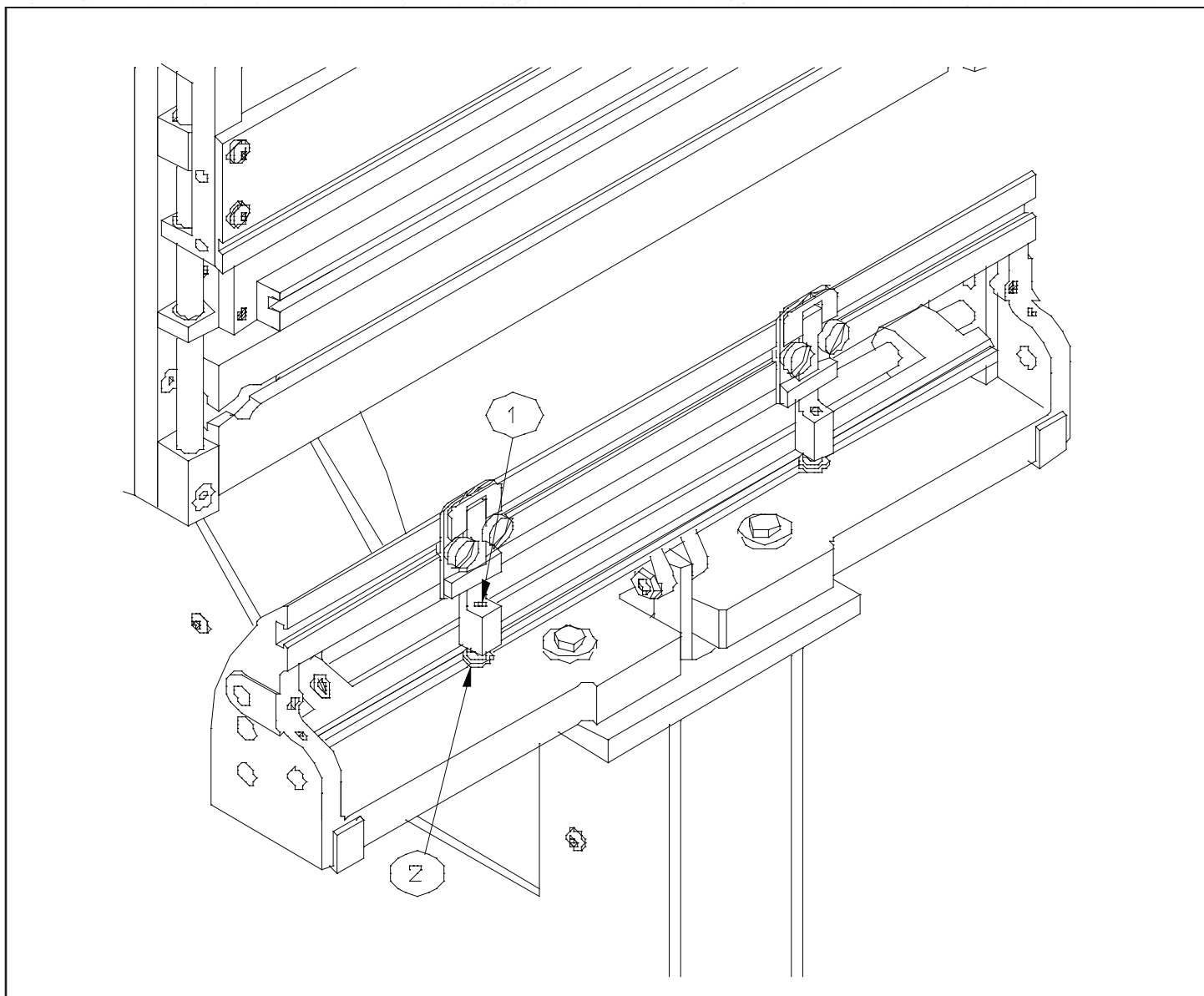
### 3.2 RAISING OR LOWERING THE CLINCHERS (See Figure 3)

**! WARNING:** ALWAYS DISCONNECT THE POWER SUPPLY BEFORE MAKING ANY ADJUSTMENTS OR SERVICING THE STITCHER.

If staples are being loosely clinched, requiring that the clinchers be raised or lowered, proceed as follows:

Loosen the clincher adjustment binder screw (1). Rotate the clincher adjustment screw (2) to raise or lower the clincher points as needed.

Retighten the binder screw (1). Turn the machine over manually a few revolutions and ensure that the machine is operating freely before running under power.



**Figure 3 - Raising or Lowering Clincher**

## 4.0 MAINTENANCE

To insure continuous operation of the M17 Stitcher, the operator should be sure that the machine is regularly lubricated and carefully maintained. The operator should periodically inspect all moving parts for signs of wear and, when required, replace the worn parts.

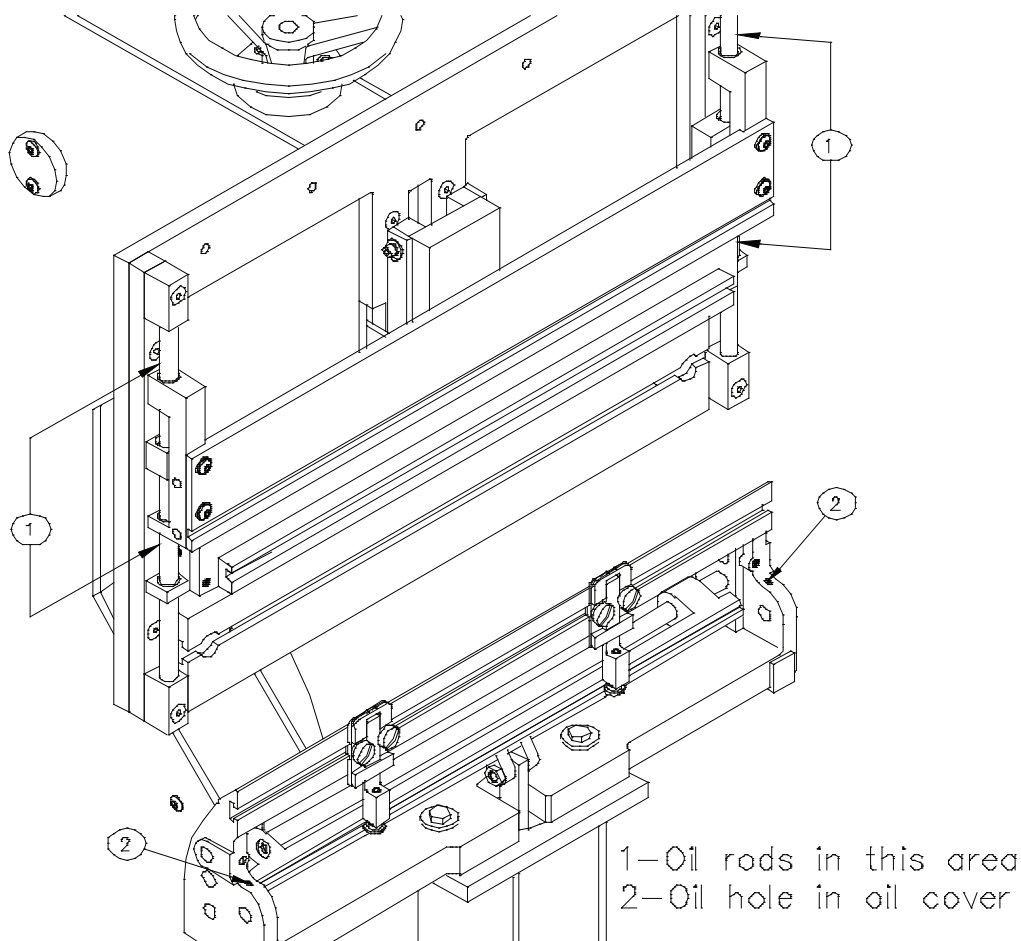
The following instructions are provided so that the operator will understand how to lubricate the machine, and how to adjust the clutch.

### 4.1 LUBRICATION (See Figure 4)

**! WARNING** ALWAYS DISCONNECT THE POWER SUPPLY BEFORE MAKING ANY ADJUSTMENTS OR SERVICING THE STITCHER.

Use an S.A.E. No. 10 oil for lubricating the M17 Stitcher. Machines that are in constant use should be lubricated daily. Machines that are operated periodically should be lubricated just prior to use. Usually only a drop of oil is required at each lubrication point in the Stitcher. After lubricating the machine, wipe off any excessive oil.

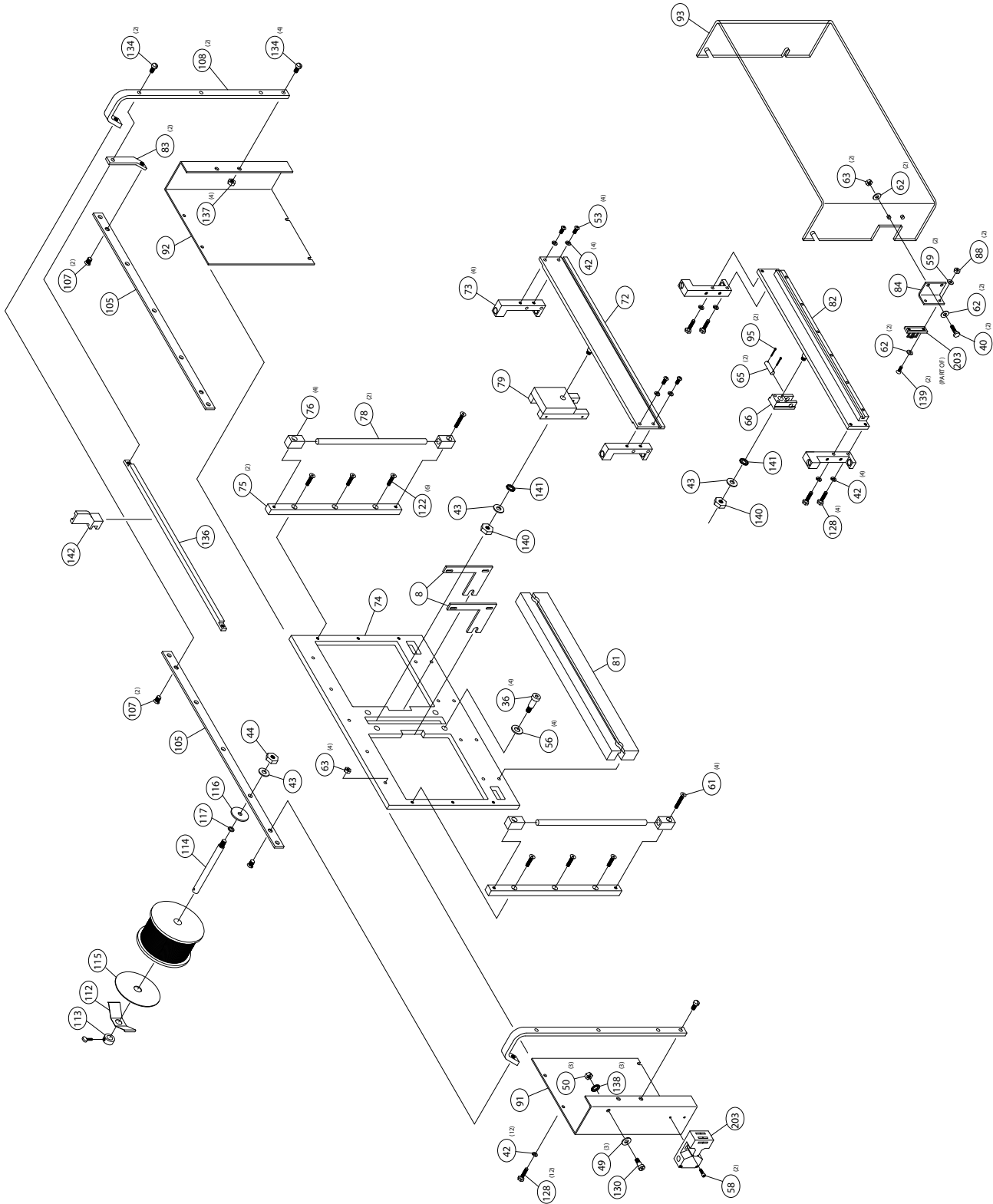
Refer to the stitcher head Operation Manual for additional lubrication points on each stitching head.

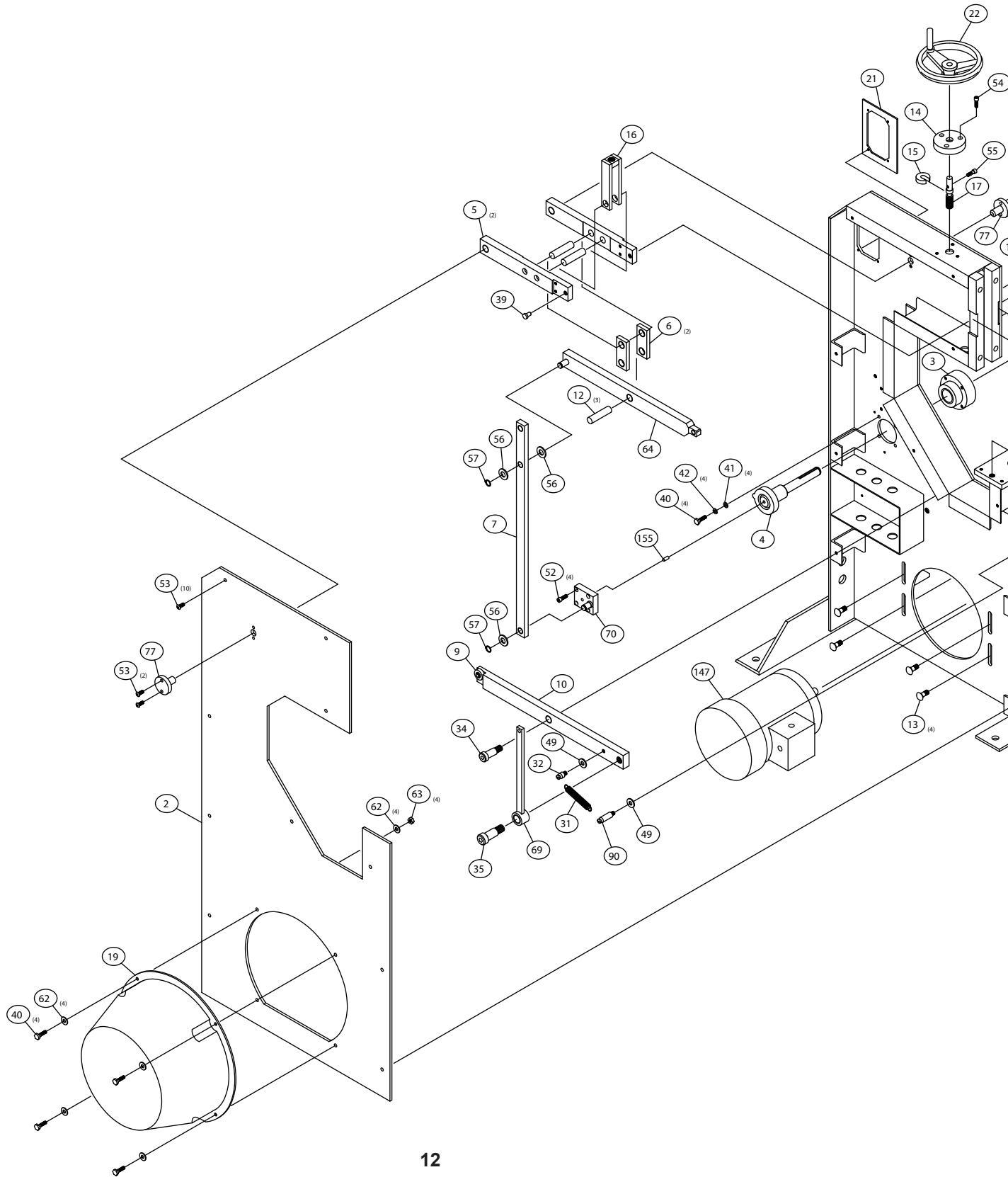


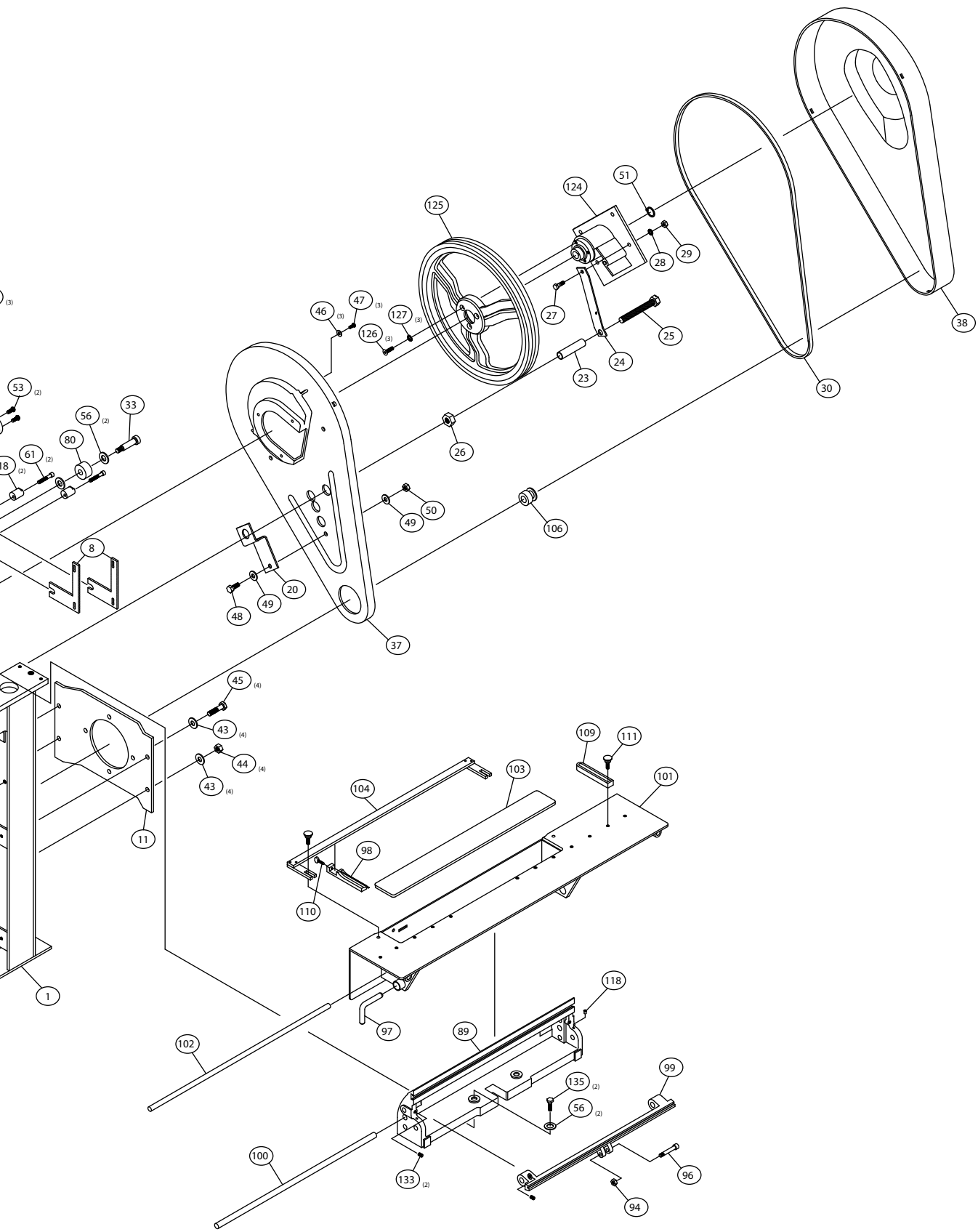
**Figure 4 - Lubrication Points**

## 5.0 M17 DIAGRAMS & PARTS LIST

The following diagrams show exploded views of the M17 Stitcher. The Deluxe Stitcher Item Number and description can be found by using the Item number table that follows.







INDEX	PART NUMBER	DESCRIPTION	QTY
1	G30001A	FRAME WELDMENT	1
2	G30002	COVER PLATE	1
3	G30006A	BEARING HOUSING ASSY	1
4	G30007C	CRANK SHAFT ASSY	1
5	G30011A	ADJUSTER LEVER ASSY	2
6	G30017A	PIVOT LINK ASSY	2
7	G30020A	UPRIGHT LINK ASSY	1
8	G30147	ADJUSTER FORK	2
9	G30041A	CLINCHER ROLLER ASSY	1
10	G30043	CLINCHER LEVER	1
11	G30048	MOTOR MOUNTING PLATE	1
12	G30049	PIN, DOWEL 5/8 X 2-1/2	3
13	G30067	BOLT, 3/8-16 X 1 RD HD SQ. NECK	4
14	G30099	ADJUSTER CRANK HOUSING	1
15	G30100	ADJUSTER CRANK SHAFT INSERT	1
16	G30101	ADJUSTER YOKE	1
17	G30102	ADJUSTER SHAFT	1
18	G30103	ADJUSTER STOPS	2
19	G30117	MOTOR COVER	1
20	G30118	BELT GUARD BRACKET	1
21	G30127	STARTER MOUNTING FLANGE	1
22	G30128	HAND WHEEL	1
23	FC9632	ANCHOR SPACER	1
24	FC9656	CLUTCH ANCHOR	1
25	UA8164	SCREW, 1/2-13 X 4 HHCS	1
26	HN1213.2	NUT, 1/2-13 HEX JAM BLACK	1
27	7681	SCREW CLUTCH ANCHOR TOP	1
28	SW14	WASHER, 1/4 INT T LOCK ZINC	1
29	HN1420.5	NUT, 1/4-20 HVY HEX ZINC	1
30	850730C	V-BELT	1
31	35	SPRING	1
32	406	CLINCHER OPERATING LEVER STUD	1
33	G30061	SCREW, 1/2 X 1-1/2 SHOULDER SCREW	1
34	G30063	SCREW, 5/8 X 1 SHOULDER SCREW	1
35	G30064	SCREW, 3/4 X 1-1/4 SHOULDER SCREW	1
36	G30065	SCREW, 1/2 X 1 SHOULDER	4
37	7675B	BELT GUARD	1
38	7676B	BELT GUARD	1
39	G30130	ADJUSTER STUD	1
40	P7507	SCREW, 1/4-20 X 3/4 HHCS	10
41	PW14.6	WASHER	4
42	LW14	LOCK WASHER	25
43	PW38	WASHER, 3/8 FLAT	8
44	HN3816	NUT, 3/8-16 PLAIN ZINC	3
45	UA6112.1	SCREW, 3/8-16 X 5/8 HHCS	4
46	PW10.3	WASHER, 3/16 PLAIN ZINC	4
47	UA3806.9	SCREW, 10-32 X 3/8 SBHCS	3
48	UA5112.1	SCREW, 5/16-18 X 3/4 HHCS	1
49	PW516	WASHER, 5/16 SAE FLAT	7
50	HN51618	NUT, 5/16-18 HEX BLACK	4
51	P7863	RETAINING RING 5100-75	1
52	UA4812.1	SCREW, 1/4-20 X 3/4 SHCS	4
53	UA4810.5	SCREW, 1/4-20 X 5/8 BHCS	18

54	UA4810.1	SCREW, 1/4-20 X 5/8 SHCS	3
55	UA4808.3	SCREW, 1/4-20 X 1/2 SHCS	1
56	PW12	WASHER, 1/2 FLAT BLK ZINC	11
57	P8054	RETAINING RING 5100-50	2
58	UA3808.1	SCREW, 10-32 X 1/2 SHCS	6
59	PW10	WASHER, #10 SAE FLAT	6
60	LW10	LOCK WASHER, #10	4
61	UA4816.1	SCREW, 1/4-20 X 1 SHCS	2
62	PW14	WASHER, 1/4 USS FLAT BLK ZINC	18
63	HN1420	NUT, 1/4-20 HEX ZINC	10
64	G30013A	DRIVE LEVER ASSY	1
65	G30131	SLIDER PIN	1
66	G30016	SLIDER	1
69	G30039A	CLINCHER LINK ASSY	1
70	G30005A	CRANK THROW ASSY	1
71	G30018A	PIVOT FORK ASSY	1
72	G30076A	ADJUSTER RAIL ASSY	1
73	G30075A	GUIDE ROD SLIDER	4
74	G30078	MULTI HEAD FACE PLATE	1
75	G30079	FACE PLATE SIDE RAIL	2
76	G30080	GUIDE ROD END CAPS	4
77	G30097	ADJUSTER PIVOT PIN	2
78	G30085	SLIDER GUIDE RODS	2
79	G30077	ADJUSTER PLATE	1
80	G30152	ADJUSTER SPOOL	1
81	G30081	BONNET RAIL	1
82	G30082A	DRIVE RAIL ASSY	1
83	G30149	LOWER SPOOL BAR BRACKET	2
84	G30124	ACTUATOR KEY BRACKET	1
88	HN1024	NUT, 10-24 ZINC PLATED HEX	2
89	17106D	CLINCHER RAIL	1
90	36	PIN	1
91	G30133	GUARD MOUNT, LEFT	1
92	G30134	GUARD MOUNT, RIGHT	1
93	G30135	GUARD	1
94	HN1420.13	NUT, 1/4-20 NYLON INSERT	1
95	UB3916.1	PIN, COTTER	2
96	P6698	SCREW, 5/16 X 1 SHOULDER SCREW 1/4-20	1
97	16148	PIN	2
98	16160	BACK GAGE	1
99	17110B	LEVER	1
100	17111	PIVOT	1
101	17145FA	TABLE ASSY	1
102	17146	PIVOT	1
103	17149	PLATE	1
104	17161A	BAR ASSY	1
105	17280	SPOOL BAR	2
106	850732	MOTOR PULLEY, M17-AST	1
106	850696	MOTOR PULLEY, M17-BST	1
107	17281	SCREWS	4
108	17282	BRACKET	2
109	18572A	WORK STOP WELDMENT	2
110	425	SCREW, THUMB	3
111	63	SCREW	4
112	7690	TENSION SPRING	10

113	7691	SET COLLAR, REAMED	10
114	7693	SPOOL STUD	10
115	M11009	PLASTIC WASHER	10
116	2245	SPOOL STUD WASHER, LARGE	10
117	PG10271	WASHER, 9/16 SAE FLAT	10
118	87922	OIL HOLE COVER	2
122	P2811	SCREW, 1/4-20 X 1 SFHCS	6
124	850677	CLUTCH, M17-AST	1
124	850678	CLUTCH, M17-BST	1
125	7678B	DRIVE PULLEY	1
126	UA4812.7	SCREW, 1/4-20 X 3/4 FHSCS	3
127	SW14.1	WASHER, 1/4 EXT T LOCK CUP	3
128	UA4116.4	SCREW, 1/4-20 X 1 HHCS	16
130	SU-0308853	SCRW, 3/8 X 3/8 SHOULDER	3
132	UA6812.1	SCREW, 3/8-16 X 3/4 SHCS	4
133	38	SCREW, 1/4-28 X 3/8 SLOTTED SET	3
134	UA5210.1	SCREW, 5/16-18 X 5/8 SLOTTED FILLISTER HD	4
135	PG10512	SCREW, 1/20-20 X 1HHCS	2
136	17289	GUIDE SPRING BRACKET BAR	1
137	HN51618.2	NUT, 5/16-18 HEX JAM	4
138	SW516.2	WASHER, 5/16 INTERNAL TOOTH	3
139	UA3410.4	SCREW, 10-32 X 5/8 SFHCS	2
140	HN3816.2	NUT, 3/8-16 HEX JAM	1
141	SU-3309006	WASHER, 3/8 EXT TOOTH	1
142	17288	WIRE GUIDE SPRING BRACKET - M17	2
142	G20369	WIRE GUIDE SPRING BRACKET - M17G8	2
147	850310	MOTOR 3/4 HP-1725 RPM	1
155	G20243	DOWEL PIN, 1/4 X 9/16	1
200	850302	STARTER ENCLOSURE	1
201	850303	TERMINAL STRIP	1
202	850304	FOOTSWITCH	1
203	850308	SAFETY INTERLOCK SWITCH	1
204	851005	STRAIN RELIEF	2
205	86243	POWER CORD, DOMESTIC	1
205	850307	POWER CORD, CONTINENTAL EUROPE	1
206	850314	STRAIN RELIEF	3
207	850315	STRAIN RELIEF NUT	2
208	850305	UNDERVOLTAGE TRIP, 115V	1
208	850306	UNDERVOLTAGE TRIP, 230V	1
209	850311	MANUAL MOTOR STARTER	1
210	7683	FLANGED BUTTON SCRE	5
211	7684	U-NUT	5
212	7685	BELT GUARD MOUNTING STRAP	5
213	7687	PUSH IN RIVET	5
214	850322	STARTER ASSY 3/4-115V	1
214	850323	STARTER ASSY 3/4-230V	1
215	A1178	SIDE PAPER GUIDE RH	1
216	A1185	SIDE PAPER GUIDE LH	1
217	P7917	WIRE NUT(ORANGE)	2



## 6.0 CLUTCH-BRAKE MAINTENANCE

 **WARNING** ALWAYS DISCONNECT THE POWER SUPPLY BEFORE MAKING ANY ADJUSTMENTS OR SERVICING THE STITCHER.

This stitcher is equipped with a solenoid actuated, continuous trip, wrap spring clutch-brake unit. It is a dependable device and seldom needs service. But should a malfunction occur, the following information is a service and troubleshooting guide for maintenance of this unit.

### 6.1 ACTUATOR

The actuator is a simple, straight-forward mechanical linkage. When the actuator does not trip, the following checks should be made:

PROBLEM	CAUSE AND REMEDY
NO POWER TO THE COIL	CHECK ALL WIRING AND SWITCHING IN THE CLUTCH ACTUATION SYSTEM
LACK OF CONTINUITY IN THE COIL WINDINGS	REPLACE THE COIL
MECHANICAL BINDING OF THE PLUNGER	THE COIL MAY HAVE SHIFTED, OR THE PLUNGER END MAY HAVE MUSHROOMED DUE TO STRIKING THE BACKSTOP. IN THE LATTER, THE PLUNGER MAY BE FILED OR TURNED TO ITS TRUE DIAMETER
INSUFFICIENT CLEARANCE OF THE ACTUATOR OVER THE STOP COLLAR	ADJUST THE LINKAGE AS NEEDED
ACTUATOR LOADED BY THE STOP COLLAR SO HARD THAT THE ACTUATOR CANNOT BE PULLED BY THE COIL	BRAKING FORCE IS EXCEEDING THE LIMITS OF THE BRAKE, OR THE DIFFERENTIAL SETTING OF THE UNIT IS TOO CLOSE (SEE ASSEMBLY/DISASSEMBLY INSTRUCTIONS)

## 6.2 CLUTCH AND BRAKE SPRINGS

With the brake engaged (full limit of output), the input hub should be free to rotate by hand. With the clutch engaged, the input and output hubs should rotate together. If the unit does not rotate in either of these modes, the clearance between the hubs of the unit on the shaft may have been disturbed or damaged. See Assembly/Disassembly instructions for re-adjusting.

Listed below are additional checks to be made if the clutch does not function correctly:

PROBLEM	CAUSE AND REMEDY
CLUTCH BRAKE DOES NOT DRIVE BUT INPUT TURNS	<p><b>A.</b> DRIVE SPRING MAY BE BROKEN AT CROSSOVER POINT FROM AN OVERLOAD CAUSED BY A JAM. REPLACE SPRING AND CHECK HUBS FOR DAMAGE.</p> <p><b>B.</b> COLLAR MAY NOT SNAP FORWARD BECAUSE OF FOREIGN MATTER RESTRICTING MOVEMENT. CLEAN UNIT.</p> <p><b>C.</b> ACTUATOR DOES NOT PULL IN. SEE ACTUATOR ABOVE.</p>
CLUTCH-BRAKE JAMS AND STALLS INPUT MOTOR	<p><b>A.</b> SPRING TANG BROKEN OFF DRIVE SPRING, NOT ALLOWING CLUTCH TO DISENGAGE WHILE BRAKE IS ENGAGED. REPLACE DRIVE SPRING.</p> <p><b>B.</b> CLUTCH OUTPUT BOUND UP. CHECK CLEARANCE BETWEEN OUTPUT HUB AND BRAKE HUB.</p> <p><b>C.</b> COMPLETELY OUT OF ADJUSTMENT CAUSED BY LOSING AN INTERNAL SPRING TANG. REPLACE SPRING.</p>
OUTPUT DOES NOT REPEAT STOPPING POINT	<p><b>A.</b> NOT ENOUGH INERTIA TO ACTUATE BRAKE.</p> <p><b>B.</b> TANG BROKEN OFF BRAKE SPRING. REPLACE SPRING.</p> <p><b>C.</b> ADJUSTABLE COLLAR LOCKING SCREW MAY BE LOOSE ALLOWING ADJUSTING SCREW TO ROTATE</p>

### 6.3 DISASSEMBLY (See Figure 5)

 **WARNING** ALWAYS DISCONNECT THE POWER SUPPLY CORD FROM THE POWER OUTLET BEFORE DOING ANY DISASSEMBLY WORK.

To disassemble the clutch-brake unit (124) it will first be necessary to remove the drive pulley (125) from the stitcher by removing the V-belt (30), retaining ring (51), and clutch anchor screw (27). Disconnect the ground and solenoid wires, and swing the anchor strap (24) clear of the drive pulley assembly and slide it off of the drive shaft. Remove the three screws (126) connecting the drive pulley to the clutch-brake unit.

When disassembling the clutch-brake unit, always mark the spring tang locations with reference to which slots they go in if the same springs are to be used for reassembly. To disassemble the clutch-brake unit, proceed as follows:

Release Actuator Lever so that clutch is engaged and brake released. Remove Retaining Ring and Shim Washer, if any, from the input Hub end. Remove input Hub by rotating opposite to the drive direction. Remove Retaining Ring and Shim Washer, if any, from the Mounting Plate end.

Remove Output Shaft Springs and Control Collar assembly by rotating Output Shaft in the drive direction (DO NOT DISASSEMBLE BRAKE HUB FROM MOUNTING PLATE). Remove Control Collar from the Output Shaft and Spring assembly by extracting toward the Brake Spring end.

### 6.4 ASSEMBLY (See Figure 5)

Replace Clutch, Brake and Anti-Backup Springs as required. Assemble Springs concentric and square to the Output Shaft. Assemble Control Collar over the Output Shaft and Spring assembly by inserting from the Brake Spring end (it will be necessary to extend Brake Spring using long nose pliers). Place the Brake Spring tang in any one (1) of the nine (9) Control Collar slots at random.

Assemble Output Shaft, Springs, and Control Collar assembly to the Mounting Plate assembly by rotating Output Shaft in the drive direction. Assemble Retaining Ring to Output Shaft at the Mounting Plate end (smooth surface facing Brake Hub). Check end play between Hub and Retaining Ring with feeler gauge. There should be 0.004" to 0.010" end play. Use Shim Washer to adjust.

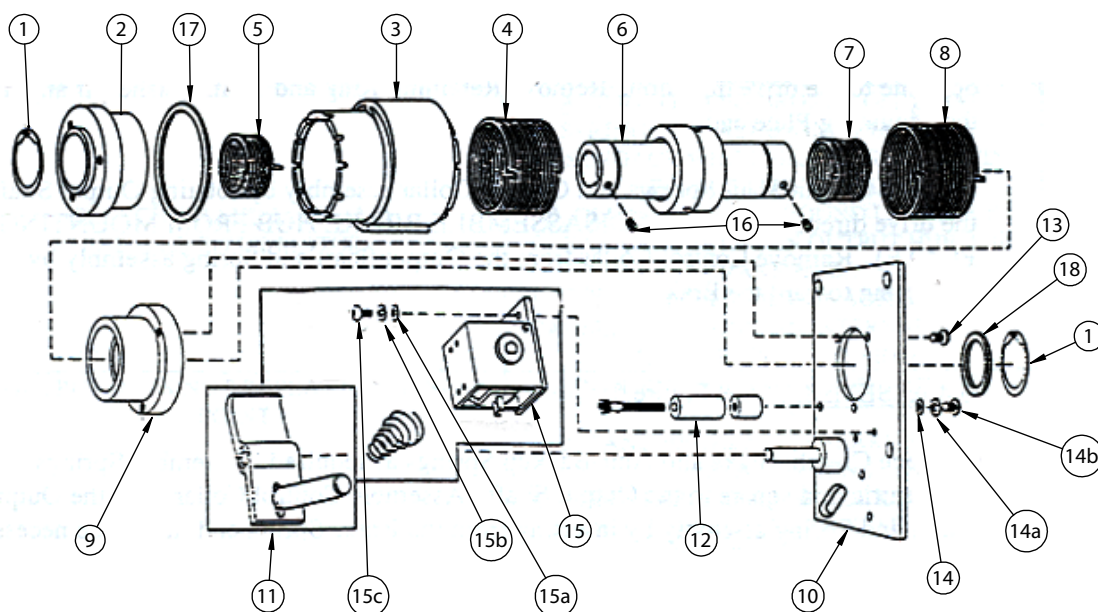
Rotate Output Shaft in the drive direction until it reaches a full brake position. With the Clutch Spring Tang not in slot, insert the Input Hub by rotating opposite to the drive direction. Select the one (1) of ten (10) Control Collar slots for the Clutch Spring Tang that will provide a 0.38" to 0.50" circumferential over-travel of the Control Collar when released.

**Note:** At this point it may be necessary to reselect one (1) of the nine (9) Control Collar slots for the Brake Spring Tang (release Actuator Lever, remove Clutch Spring Tang from slot, then move Control Collar axially toward the Input Hub end and rotate it opposite to the drive direction to pick up the next slot). Continue to select Control Collar slots until the 0.38" to 0.50" specification is achieved.

Assemble Retaining Ring to Output Shaft at the Input Hub end (smooth surface facing Input Hub). Check end play between Input Hub and Retaining Ring with feeler gauge. There should be 0.002" to 0.003" end play on the Input Hub.

Reassemble unit to machine.

**IMPORTANT:** After Clutch is assembled to machine, the Clutch Plate should be free to float on bearing - the anchor strap is only there to prevent rotation of the plate.



**Figure 5-Clutch Brake**

INDEX	PART NO	DESCRIPTION
1	850886	Retaining Ring
2	851321	Input Hub
3	850888	Control Collar Assembly
4	850889	Brake Spring
5	850991	Anti-Overrun Spring
6	850891	Output Assembly
7	850962	Anti-Backup Spring
8	850889	Brake Spring
9	850892	Brake Hub
10	850890	Plate Assembly
11	850992	Actuator Assembly
12	850993	Actuator Limit Stop
13	850994	Button Head Cap Screw (3)

INDEX	PART NO	DESCRIPTION
14	850995	Lockwasher - Flat (2)
14a	850996	Lockwasher - Split (2)
14b	850997	Button Head Cap Screw
15	850998	Coil Assembly 230V - 50HZ
	850999	Coil Assembly 115V - 60HZ
15a	850995	Lockwasher - Flat
15b	850996	Lockwasher - Split
15c	851123	Cap Screw (2)
16	851124	Set Screw (2)
*17	851125	Clutch Shim
*18	851126	Clutch Shim .005"
	851127	Clutch Shim .010"

**\*\*Shims used as required**

## 6.5 LUBRICATION

The clutch-brake unit is designed with the bearing parts made from sintered metal that has been impregnated with oil and normally do not need to be re-lubricated. In cases where there is severe duty, the unit may be re-oiled or flushed out with minimal or no disassembly by using a light bearing oil as used in manufacture (Shell Bearing Infusion Oil #33). If disassembly of the unit for cleaning and oiling is necessary, follow the detailed disassembly instructions to the point needed, flush and wipe parts in the oil to be used for re-lubrication. DO NOT USE SOLVENT to clean the parts. To get more cleaning action for the oil, it may be heated while cleaning the components, but bring the parts back to ambient temperature submerged in cool oil.

## 6.6 COIL REPLACEMENT

Place the Spring onto the Plunger with the narrow end towards the Actuator. Slide the Solenoid onto the Actuator and Plate Assembly. Assemble the Solenoid to the Plate Assembly with the cap screws and washers. DO NOT tighten more than finger tight.

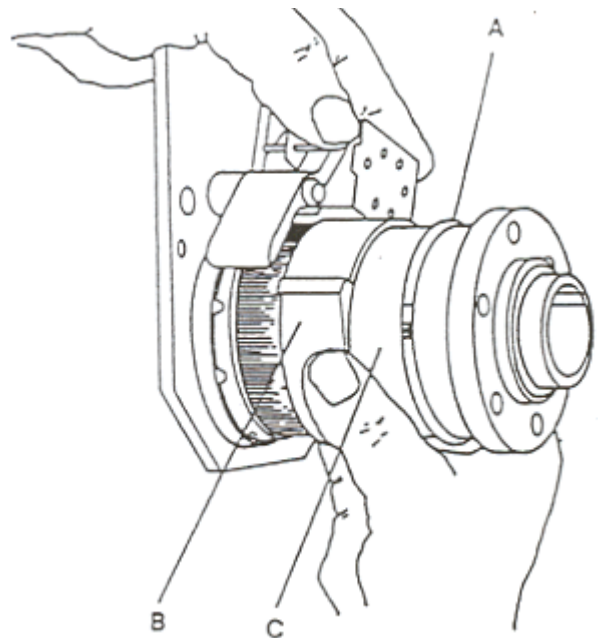
Energize the Coil and adjust the gap between the Actuator and the top of the Collar Stop to 0.015" to 0.030" by sliding the Solenoid assembly. Note: push the Collar toward the Actuator to allow for Collar movement. Tighten the cap screws.

## 6.7 CONTROL COLLAR ADJUSTMENT (See Figure 6)

The stopping position of the head can be changed if necessary by adjusting the position of the stop cam on the control collar sleeve. Turn the machine manually until the driver is in the desired stopping position, then proceed as follows:

Work Retaining Ring "A" out of its groove and slide it forward on Sleeve "C". Slide Cam "B" off Splines, rotate to align Collar Stop with Actuator and slide the Cam back on the Splines. The Actuator Pawl will have to be held clear during this operation. Slide the Retaining Ring back into its groove.

**Note:** Make sure brake is locked up before proceeding to insure getting the proper stop point.





# Declaration of Conformity

We, DeLuxe Stitcher Company, Inc.

3747 N. Acorn Lane  
Franklin Park, IL 60131 U.S.A

hereby declare under our sole responsibility that the

## **SM-CE Stitching /Stapling Machines**

to which this declaration relates is in conformity with the following European product safety directives:

### **Machinery Safety Directive**

(89/392/EEC and amendments  
91/368/EEC, 93/44/EEC, 93/68/EEC)

### **Electromagnetic Compatibility Directive**

(89/336/EEC and amendments  
91/C162/08, 92/31/EEC, 93/68/EEC)

as is verified by compliance with the following standards:

EN 60204-1:1992	prEN 894-1:1992	prEN 953:1992
EN 294:1992	prEN 894-3:1992	EN 55014:1193
prEN 614-1:1991	prEN 1050:1993	EN 55104:1995

Executed for DeLuxe Stitcher Company, Inc.

this              day of                              in the year  
                    first                              January                              2009

By Frank P. Cangelosi

Signature

Title President

*Frank P. Cangelosi*





# **LIMITED WARRANTY**

DeLuxe Stitcher Company, Inc. warrants to the original retail purchaser that this product is free from defects in material and workmanship and agrees to repair or replace, at DeLuxe Stitcher's option, any defective product within 90 days from the date of purchase. This warranty is not transferable. It covers damage resulting only from defects in material or workmanship and does not cover conditions or malfunctions resulting from normal wear, neglect, abuse or accident.

This warranty is in lieu of all other express warranties. Any warranty of merchantability or fitness for a particular purpose is limited to the duration of this warranty. DeLuxe Stitcher shall not be liable for any incidental or consequential damages.

Some states do not allow limitations on how long an implied warranty lasts, or the exclusion or limitation of incidental or consequential damages, so the above limitations or exclusions may not apply to you. This warranty gives you specific legal rights and you may also have other rights which vary from state to state.

To obtain warranty service you must return the product, at your expense, together with proof of purchase to an authorized DeLuxe Stitcher Company Graphic Arts Dealer.

Always use genuine DeLuxe Stitcher parts. When ordering parts, please identify the part number, the part name, the wire size and crown size of your Stitcher.



COMPANY INC.

solving your wire stitching needs for 125 years...

## **ISP** Stitching & Bindery Products

3747 Acorn Lane • Franklin Park • Illinois 60131

Phone: 847-455-4400 • 800-634-0810

Fax: 847-455-4900 • 800-417-9251

<https://www.deluxestitcher.com>