



COMPANY INC.

solving your wire stitching needs for 125 years...

ISP Stitching & Bindery Products

Machine Serial Number : _____

Head Serial Number : _____

Date Purchased : _____

Model M30 Stitchers

OPERATION AND MAINTENANCE MANUAL

M30-AST Stitcher.....115V and 60HZ

M30-BST Stitcher.....230V and 50HZ

Before using this Stitcher, all operators must study this manual and follow the safety warnings and instructions. Keep these instructions with the M30 Stitcher for future reference. If you have any questions, contact your local DeLuxe Stitcher Graphic Arts Representative or Distributor.



*THANK YOU FOR CHOOSING THE
MODEL M30
FOR YOUR BINDING NEEDS.*

WARNING!

Model M30 Stitchers

Operators and others in the work area should always wear safety glasses to prevent serious eye injury from fasteners and flying debris when loading, operating, or unloading this machine.

Do not operate this stitcher without all guards in place. The stitcher will not operate without the front guard closed properly. Do not modify the guards in any way. Always disconnect the power supply before removing any guards for servicing.

Never operate the machine with wire feeding through the head unless there is stock above the clinchers, otherwise serious damage may result.

Always turn power off when making adjustments. Always disconnect the power supply before any disassembly work.

Table of Contents

Specifications	4
Recommended Wire Sizes	6
Introduction	7
Installation	8
Assembly	9
Operating Adjustments	
Wire Threading	13
Wire Straightening	14
Adjusting the Machine for Thickness of Work	15
Adjustments and Settings	
Adjusting the Left Leg	15
Adjusting the Clincher Points	16
Adjusting the Machine for Stab Stitching	18
Maintenance	
Lubrication	19
Troubleshooting	20
Cycling Machine Manually	21
Adjusting the V-Belt	22
Cleaning	23
Disassembling the Head	23
Ordering & Replacing Spare Parts	25
Clutch-Brake Maintenance	33
Assembly Drawings	38
Part Number / Description Cross-Reference	58
Registration Card	65
Wear/ Replacement Parts	66
Warranty	67
Declaration of Conformity	68

<p style="text-align: center;">Always disconnect the power supply before making any adjustments or servicing the stitcher.</p>	WARNING
---	----------------

Specifications

Weight

Shipping Weight	670 lbs [304 kg]
Wire Spool	5 lbs. [2.3 kgs] or 10lbs. [2.6 kgs] optional
Foot Switch	4.5 lbs. [2.0 kgs]
Table	27 lbs. [12.3 kgs]
Skid Size	30" x 40" x 70" [76.2cm x 101.6cm x 177.8cm]

Physical Dimensions

Height	66.5 " [168.9 cm]
Width	
With Table	30" [76.2 cm]
Without Table	21 3/4" [55.2 cm]
Depth	30" [76.2 cm]

Stitching Capacity	Two Sheets to 1-1/4" [30 mm] (Using 18x20 Wire)
	at 20# paper stock [75 grams/meter ²]
	Stab Stitch to 2" [50mm] (Using 18x20 Wire)

Wire Types	20-25 Round (24Rd STANDARD, 25Rd SPECIAL)
	18x20, 19x21½ (STANDARD)
	20x24, 20x25 and 21x25 (SPECIAL)

Throat Depth

Flat or Saddle	20" [50.8 cm]
----------------	---------------

Side Stops	9-30" [22.9 cm-76.2 cm]
-------------------	-------------------------

Power Requirements

M30-AST	115VAC 60 Hz
M30-BST	230VAC 50 Hz
Motor Size	3/4 HP

Minimum Recommended Circuit Capacity

M30-AST	10.7 A
M30-BST	7.1 A

Cycle Speed	125 Cycles/Minute (when running continuously)
--------------------	---

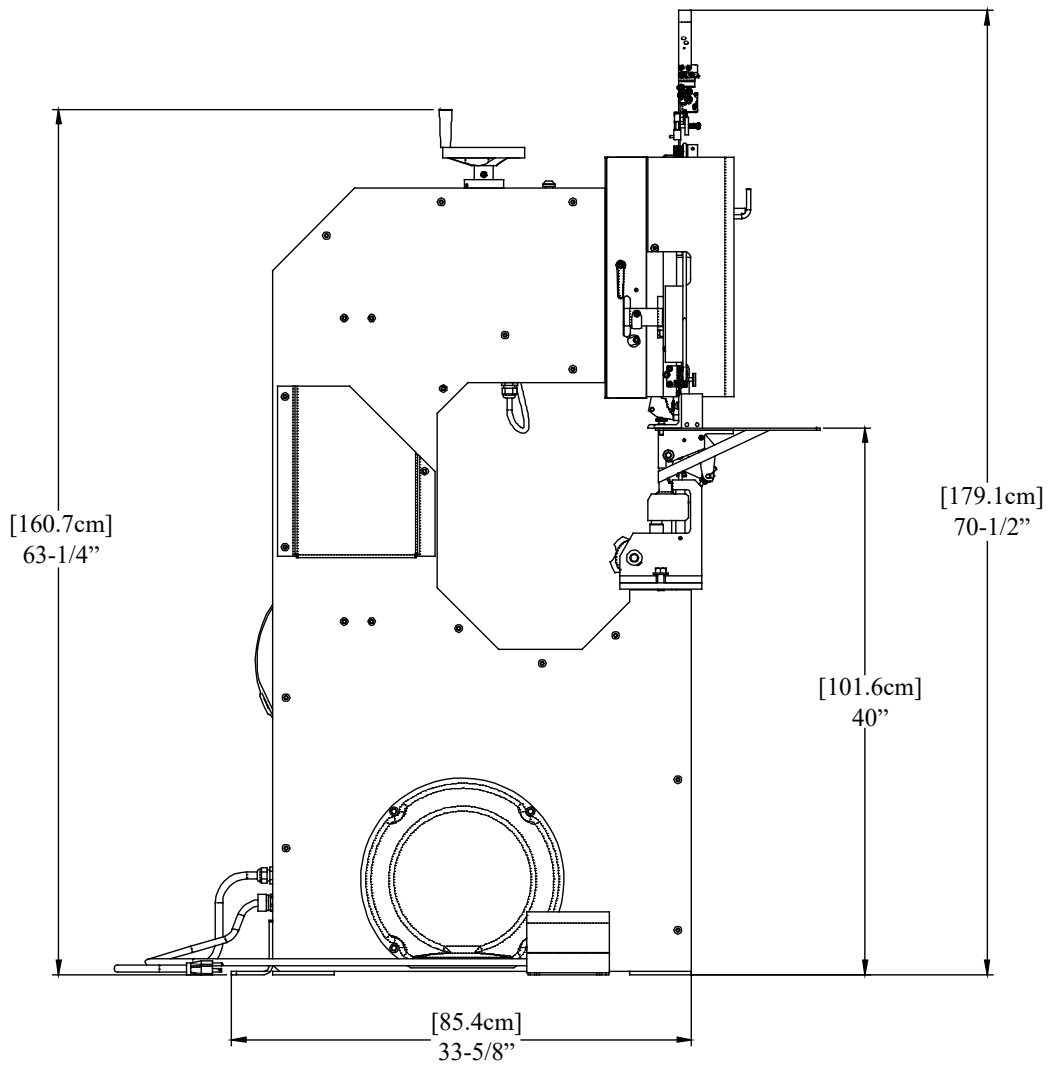
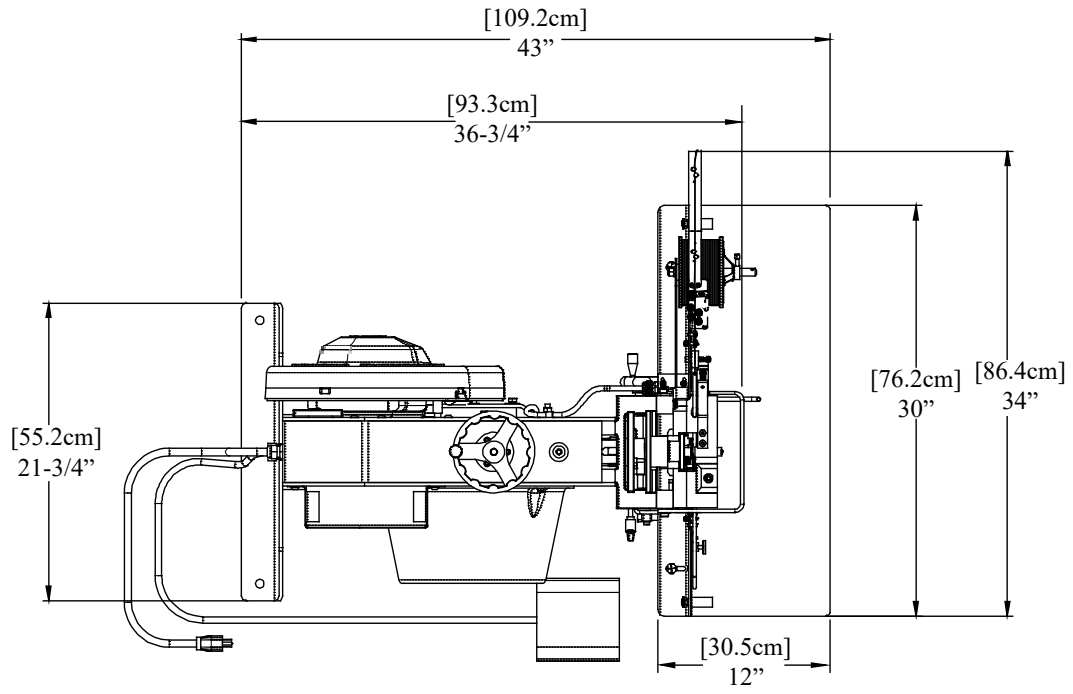

Recommended Wire Sizes (Figure 1)

The wire sizes that can be used on the M30 as well as recommended uses are listed below. Note that when size changes, several parts on the Head will have to be changed to accommodate the wire size change. Instructions for changing these parts are detailed later in this manual. Wire gauges smaller than the specific size for which the head is set can still be used, but the maximum capacity for the machine will not be reached. For example, if the Head is set for 19x21-1/2 gauge wire, it will still function properly with 20x24 gauge wire, but the stitching capacity will drop. Please refer to Figure 6 stitching capacities of different wire gauges.

Two types of Clincher Points are available for the M30. When running round wire, use the Clincher Points with part number G40955R. For flat wire, use the Clincher Points with part number G40955F.

When stitching stock over 20# it is possible that high tensile wire will be required, which is available in 21x25, 20x24, 19x21-1/2, and 18x20 flat wire sizes. Note that high tensile wire may cause increased wear on certain parts. For any stock over 33# or coated, it is recommended that 19x20-1/2 or 18x20 flat wire be used. Refer to Figure 6 for a general overview of suggested wire sizes to use for specific stitch capacities.

Wire Gauge	Type of Work	20# Stock
Install G40955R Clincher Points for:		
25 Round	Light Flat or Saddle	2-20 Sheets
24 Round	Light Flat or Saddle	2-30 Sheets
23 Round	Light Flat or Saddle	2-60 Sheets
21 Round	Medium Flat or Saddle	2- 80 Sheets
20 Round	Medium Flat or Saddle	20-100 Sheets
Install G40955F Clincher Points for:		
21 x 25 Flat	Medium Flat Only	Over 50 Sheets 1/4"- 3/8"
20 x 25 Flat	Heavy Flat Only	Over 50 Sheets 1/4"- 1/2"
20 x 24 Flat	Heavy Flat Only	Over 50 Sheets 1/4"- 3/4"
19 x 21 1/2 Flat	Heavy Flat Only	1/2"- 7/8" and Heavy Paper
18 x 20 Flat	Heavy Flat Only	7/8"- 1-1/4" and Heavy Paper

Figure 1 - Recommended Wire Sizes

Always disconnect the power supply before making any adjustments or servicing the stitcher.

WARNING

Introduction

The DeLuxe Stitcher M30 Stitcher Machine is a single-head stitcher designed to accommodate both light and heavy-duty work, stitch both flat and saddle work and can reliably stitch any thickness of stock from 2 sheets to 1-1/4" (30mm). It even stab stitches up to 2" (50mm) of material. The recommended wire sizes to be used on the M30 are: 20 to 25 gauge round wire and 20x24, 20x25, 21x25, 19x21-1/2 and 18x20 flat wire.

The M30 is easily adjusted from saddle work to flat work by tilting the work table. An adjustable work guide and adjustable work stops are easily attached to the work table and provide for accurate registering of flat work for uniformly spacing the staples. In addition a work table extension is available to accommodate larger sizes of work to be stitched. The M30 is the most versatile of all single-head machines.

Because of the length of the work table, the M30 must be secured to the floor to meet CE stability requirements. Sound level readings at the normal operator position are approximately 70 dB.

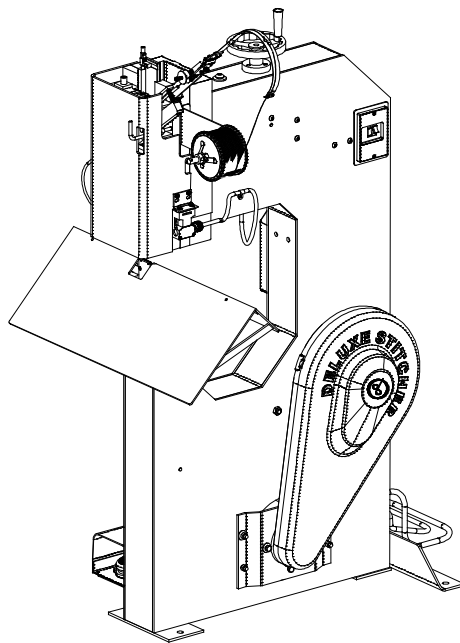

Table Set for Saddle Work

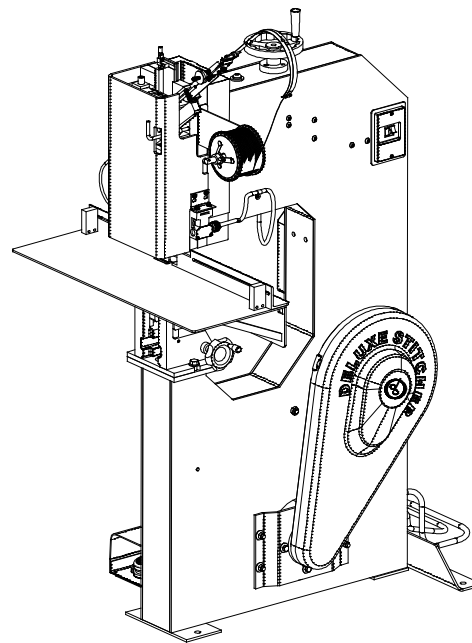

Table Set for Flat Work

Installation

Pre-Inspection

Carefully inspect the condition of the shipping container before unpacking your M30 Stitcher. If the container is broken, damaged or has been tipped over and there is evidence that the machine may be damaged, immediately notify the carrier who delivered the machine and the DeLuxe Stitcher Graphic Arts Representative from whom the M30 was purchased.

Inspection

As you carefully unpack the machine, check to make sure all components were delivered and are in good working order. Refer to **Figures 1 to 3** in this manual for reference to the following pieces:

- M30 Manual
- Complete Work Table Assembly (G40964A), the Work Guide (G40973), and two of each of the following: Large Work Stop (7423C) with Thumb Screw (63), Work Guide Screws (63), Flat Washers (PW14)
- Table Pivot Shaft (G40962)
- Upper Wire Straightening Bracket (G40767AA) and Wire Guide Spring (G40286A)
- Assembled Wire Spool Mounting Bracket (G40520) with Spool Stud (7693), Plastic Washer (M11009), Tension Spring (7690), Set Collar (7691) with Thumb Screw (P2731), 9/16" Washer (PG10271), Spool Washer (2245), 3/8" Washer (PW38), and Hex Nut (HN3816)
- Lower Wire Tube (G40599A)
- Bag of tools: 3mm Hex Key Wrench (G20360), 7mm Open End Wrench (G20364)

Pre-Installation

Please take a few moments to fill out the registration card prior to beginning installation.

IMPORTANT: Make sure that the Shipping Tab (G40978) is removed and replaced with the Clincher Plate (G40954) before proceeding to the next step. See Instruction Sheet (DBSM30UINST) in your included packet.

Always disconnect the power supply before making any adjustments or servicing the stitcher.



Assembly (Figures 2-7)

Tools required:

4mm & 6mm Hex Wrenches

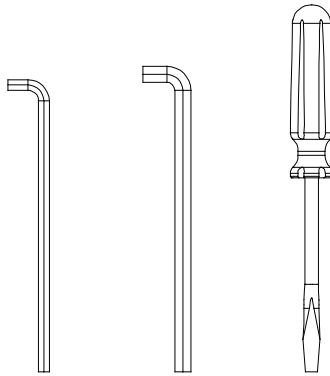

Flat Head Screwdriver

1. Remove Face Guard by lifting to disconnect it from Safety Switch and then pulling it away.
2. Remove screws & washers from shown locations.

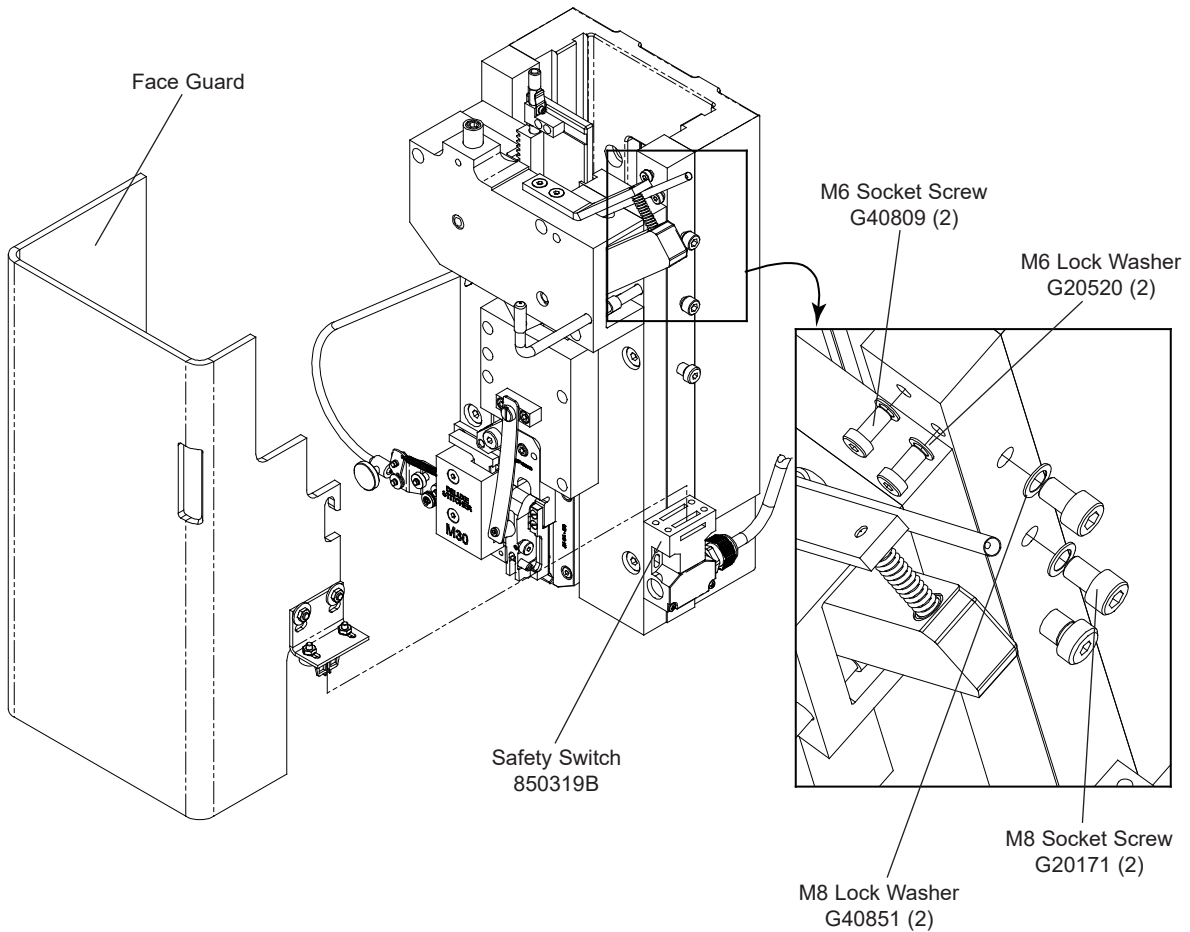

Figure 2 - Assembling

3. Attach the Upper Wire Straightening Bracket and the Wire Spool Mounting Bracket.
4. Attach the Spool Stud to the Bracket.
5. Install Wire Spool. Secure with the Set Collar and Thumb Screw.
6. Re-attach the Face Guard.

**FOR M30 MACHINES WITH SN STARTING FROM XXXXXX
LOOK AT NEW WIRE STRAIGHTENER WITH
NEW WIREGUIDE SPRING
SEE PAGE 55 AND PAGE 57**

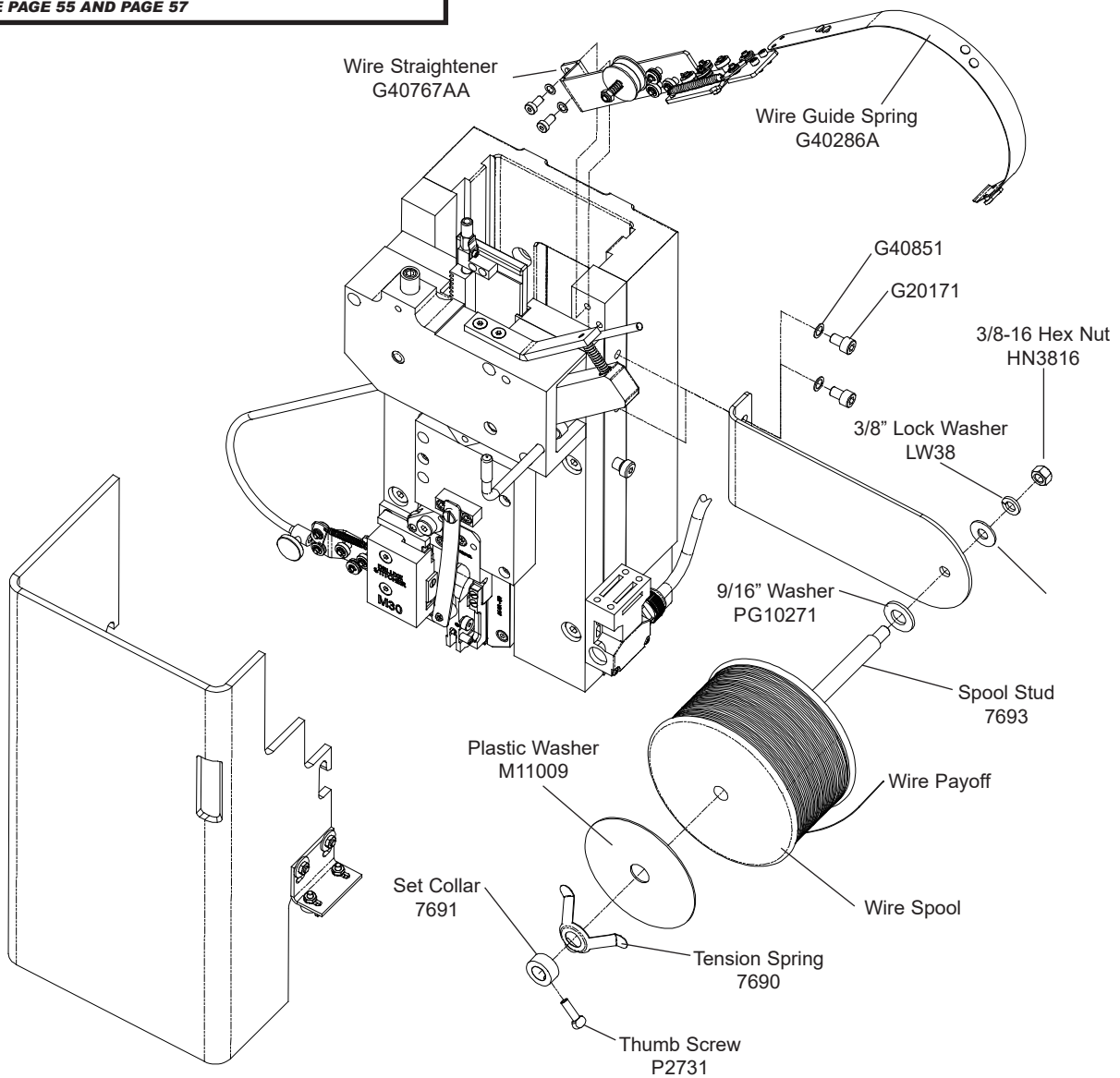

Figure 3 - Assembling

Always disconnect the power supply before making any adjustments or servicing the stitcher.

⚠ WARNING

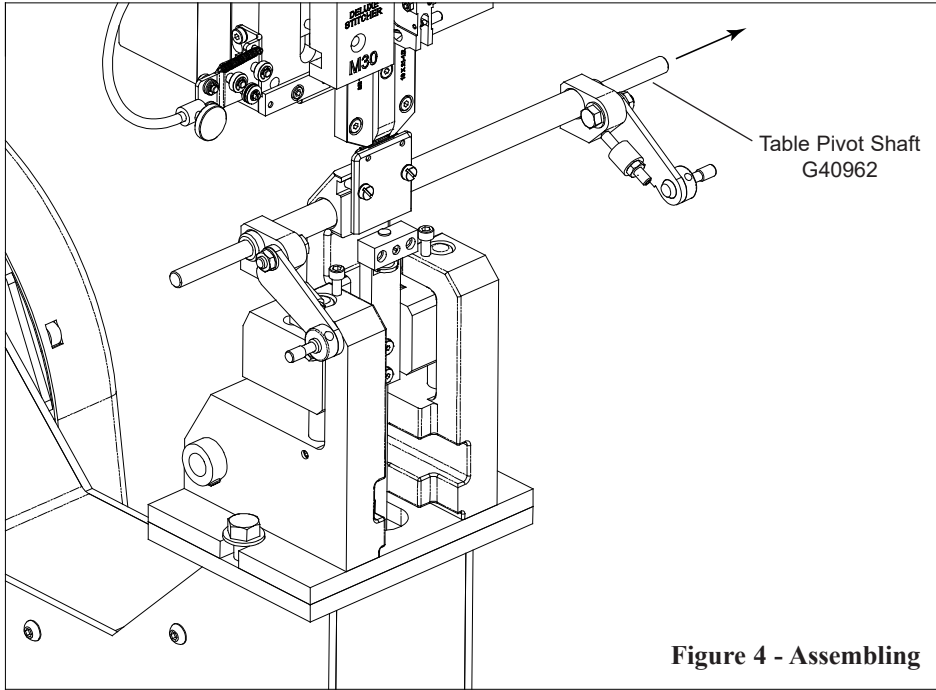

Figure 4 - Assembling

- 7. Prepare Work Table for install by disassembling the Work Guides.
- 8. Remove Table Pivot Shaft.

9. Install Work Table.

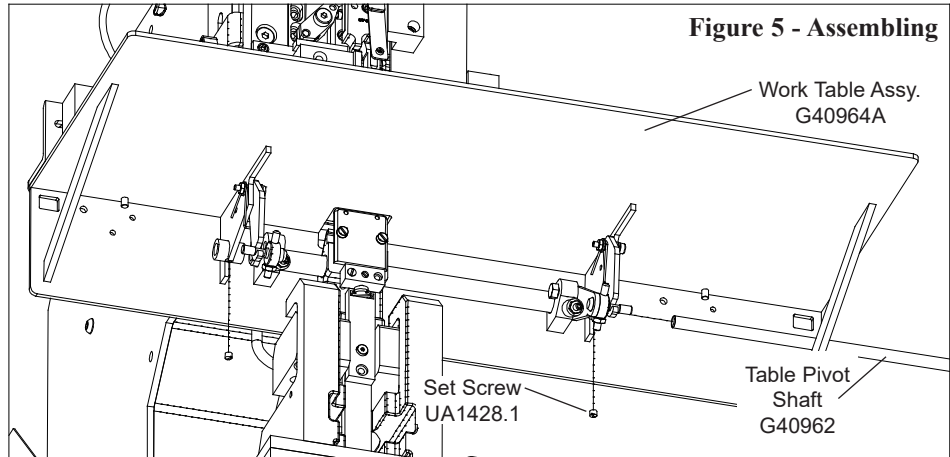

Figure 5 - Assembling

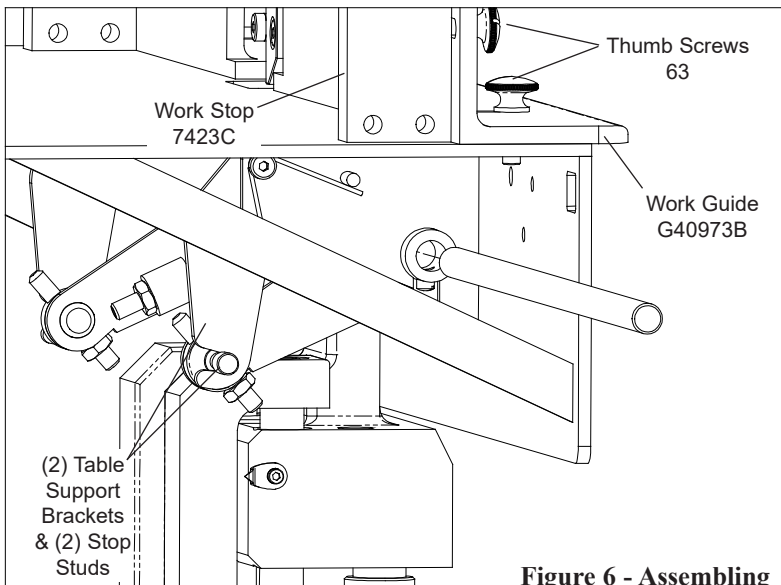

Figure 6 - Assembling

- 10. Tighten the Set Screws.
- 11. Attach the Work Guide and Work Stops as seen in Fig. 6. **(NOTE: Back Guide can only be used when stitching flat work.)**

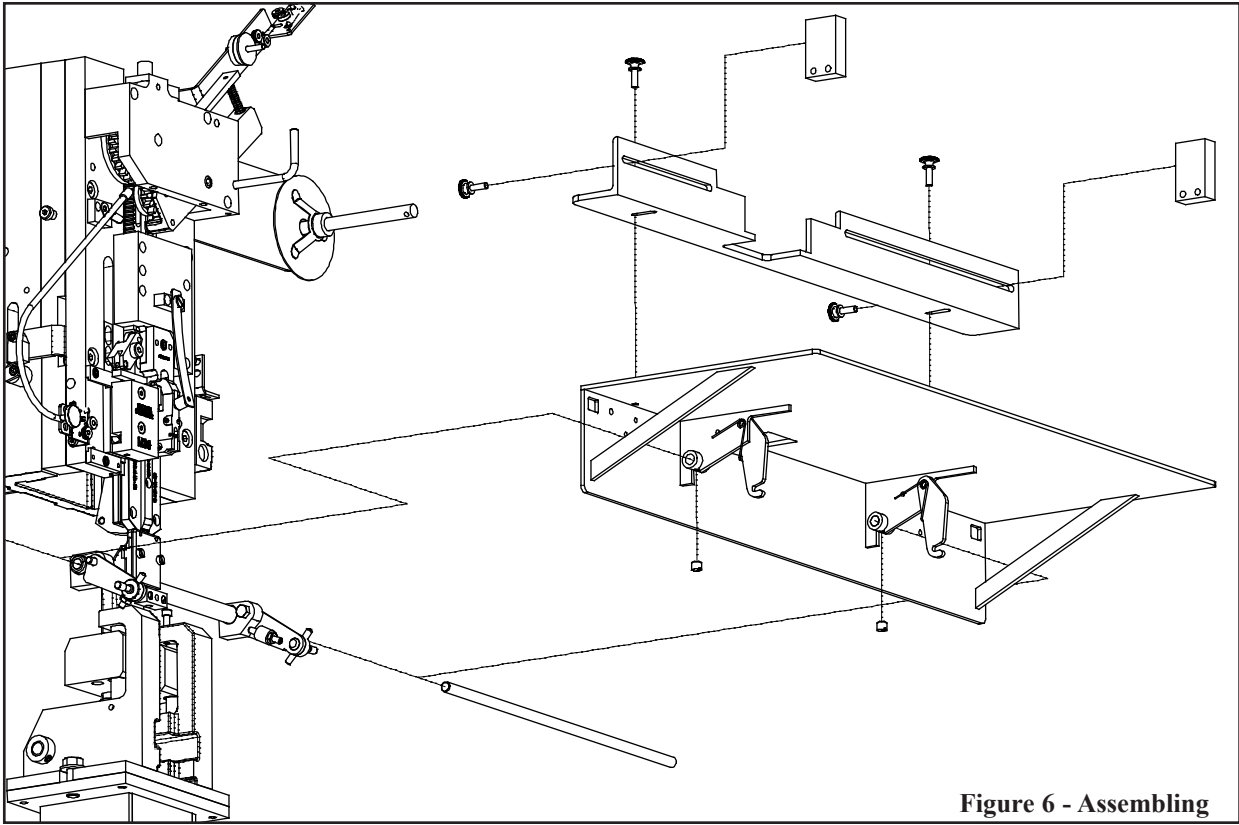

Figure 6 - Assembling

Always disconnect the power supply before making any adjustments or servicing the stitcher.

⚠ WARNING

Wire Threading (Figures 8 - 10)

**FOR M30 MACHINES WITH SN STARTING FROM XXXXXX
LOOK AT NEW WIRE STRAIGHTENER WITH
NEW WIREGUIDE SPRING
SEE PAGE 55 AND PAGE 57**

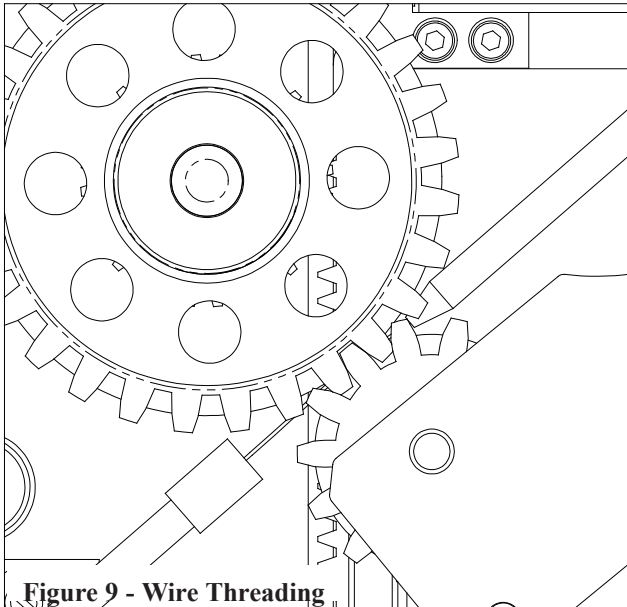
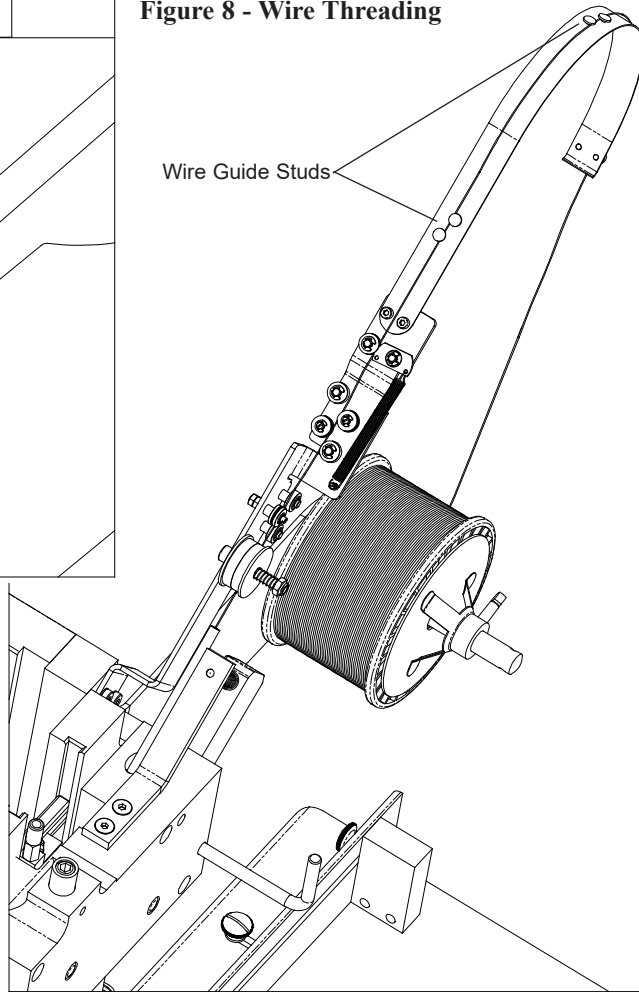

Figure 9 - Wire Threading

Figure 8 - Wire Threading

Wire Guide Studs



1. Pull wire off the spool and thread through the studs in the Wire Guide Spring Assy. (Fig. 8)
2. Continue between the Tension Pawl and its roller and through two sets of wire straightener rollers (Fig. 8). It may be necessary to turn the Adjustable Straightener Rollers to the full open position to make threading easier. (Figs. 12 & 13)
3. Now tuck the wire between the two

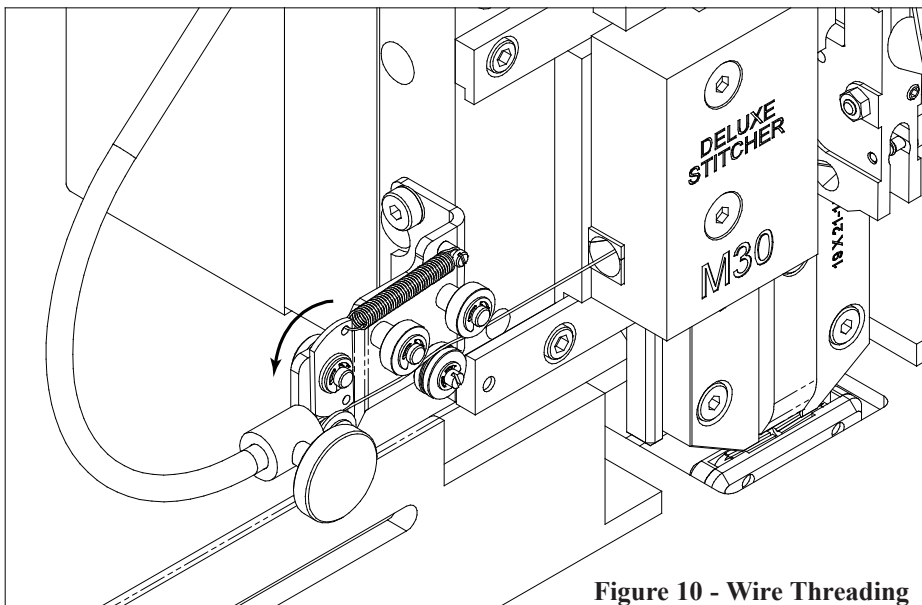

Figure 10 - Wire Threading

Oiler Felts and on into the Upper Wire Tube (Fig. 8).

4. With the Feed Release Handle in the off position, use a pair of plier to pull the wire past the Feed Gears and through the Lower Wire Tube (Fig. 9).

5. Now through the Tension Pawl, Straightener Rollers and finally into the Cutter Box.

Wire Straightening (Figure 11-14)

**FOR M30 MACHINES WITH SN STARTING FROM XXXXXX
LOOK AT NEW WIRE STRAIGHTENER WITH
NEW WIREGUIDE SPRING
SEE PAGE 55 AND PAGE 57**

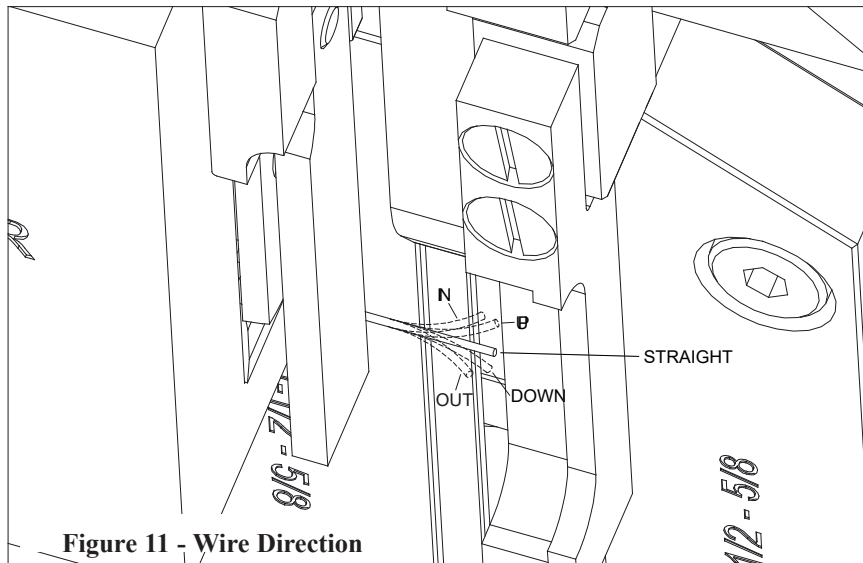

Figure 11 - Wire Direction

1. Once through, turn each of the four Adjustable Straightener Rollers until they're just touching the wire.
2. Cycle the machine several times and notice which direction the wire is curving out of the Cutter Box (Fig. 11).
3. If curving up, adjust the Lower Straightener turning the Roller (#4) counter-clockwise until wire is emerging straight (Fig 12).
4. If not fully straight,

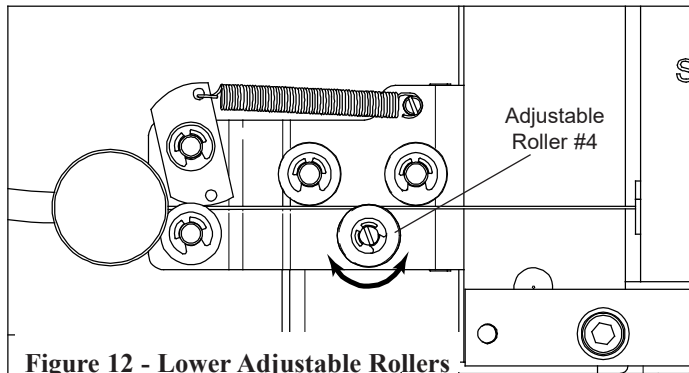

Figure 12 - Lower Adjustable Rollers

likewise adjust the upper Roller (#3) closest

Note that it will take several cycles for adjustments made to the Upper Straightener Rollers to become evident at the Cutter Box.

to the Oiler felts (Fig 13).

5. If the wire is curving towards the machine, adjust the first upper Roller (#1) towards the wire and/or turn the second Roller (#2) away from the

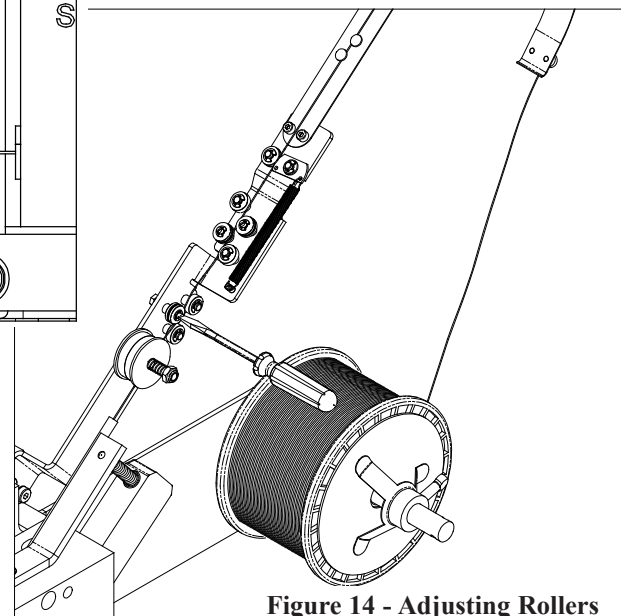

Figure 14 - Adjusting Rollers

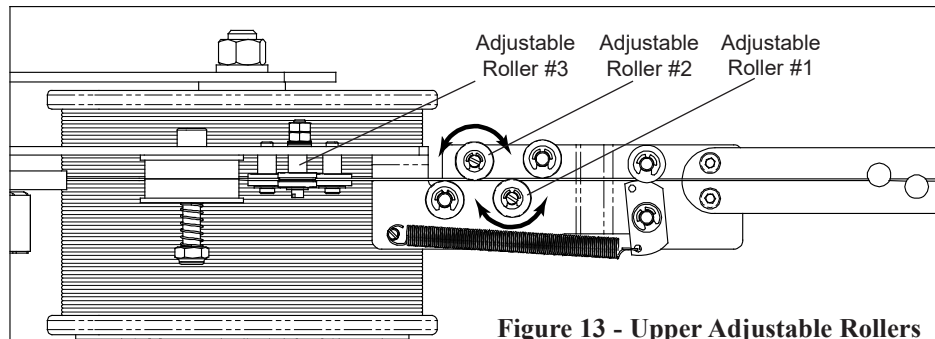

Figure 13 - Upper Adjustable Rollers

wire (Fig. 13).

6. If the wire is turning away from the machine, turn the second Roller (#2) towards the wire and/or the first Roller (#1) away from the wire.

Adjustments and Settings

Adjusting for Thickness of Work & Legs (Figure 15-17)

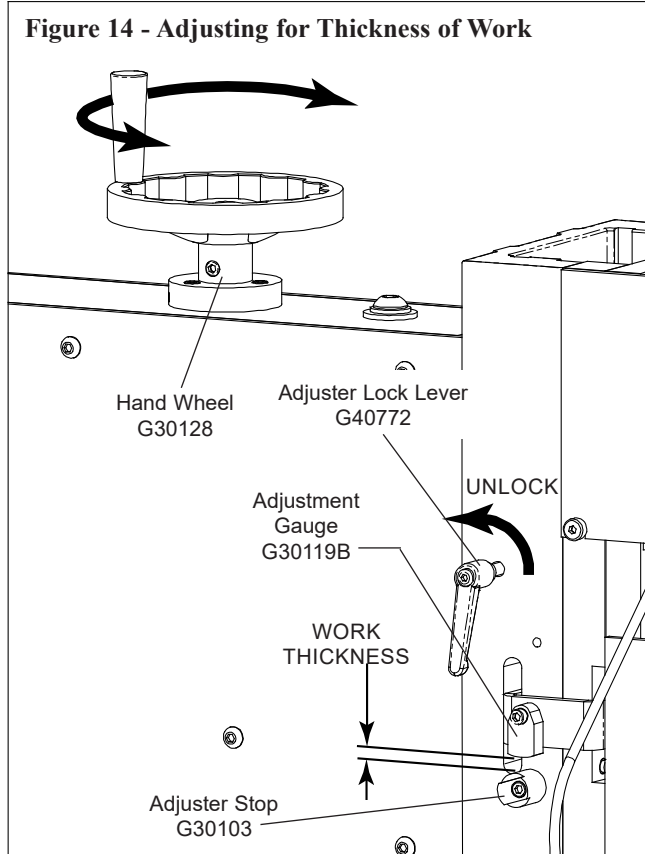

⚠ WARNING

FAILURE TO UNLOCK lever prior to compression adjustment may result in internal damage to stitcher that will not be covered by warranty. Be sure to lock when adjustment is completed.

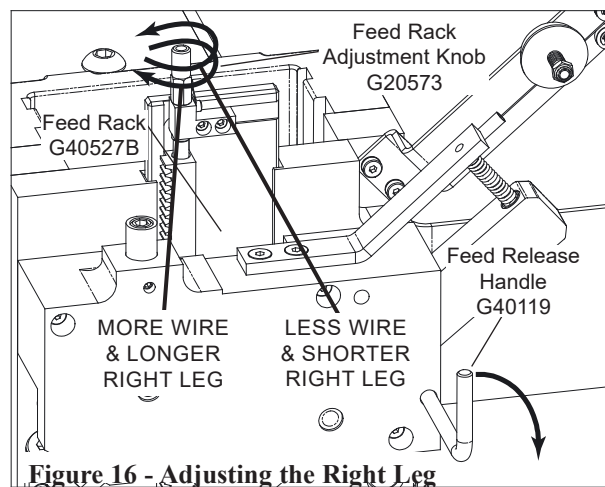
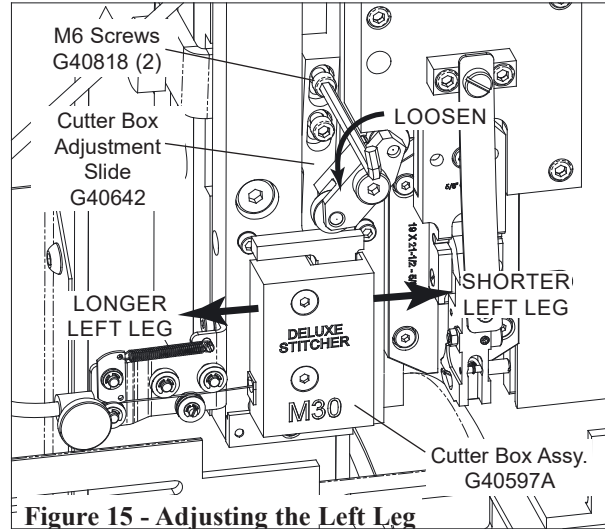

1. Unlock Adjuster Lock Lever by turning it counter-clockwise.
2. Using a sample of thickness, turn Hand Wheel clockwise until the Adjustment Gauge firmly clamps it in the work thickness area as shown in Fig. 15.
3. Back off with the Hand Wheel to release sample and then return to its pre-release position.
4. Tighten Adjuster Lock Lever and test setting. Unlock and adjust with Hand Wheel to fine tune if stitch is too loose or tight and lock again.
5. To adjust left leg length (Fig. 16), loosen Cutter Box Adjustment Slide and move Cutter Box left or right. **NOTE: Adjustment should be minor.** Tighten, test and repeat if necessary.
6. To adjust the right leg length, disengage the Feed Gears by turning the Feed Release Handle and adjust with the Feed Rack Adjustment Knob (Fig. 17).
7. Engage, test and repeat as necessary.

Adjusting The Clincher Point Height (Figures 17)

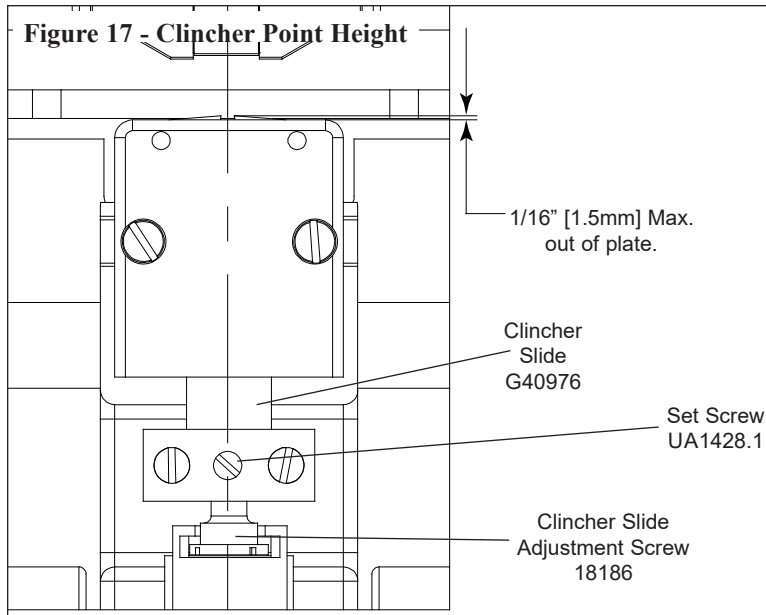

1. With the Work Table in the flat work position, check the clinch by manually cycling the machine to the point of clincher activation.
2. Loosen the Set Screw and rotate the Clincher Slide Adjustment Screw to raise or lower the Clincher Points. Once set, tighten Set Screw.
3. Complete the cycle and test. Repeat if necessary.

Adjusting The Clincher Mount (Figures 18 & 19)

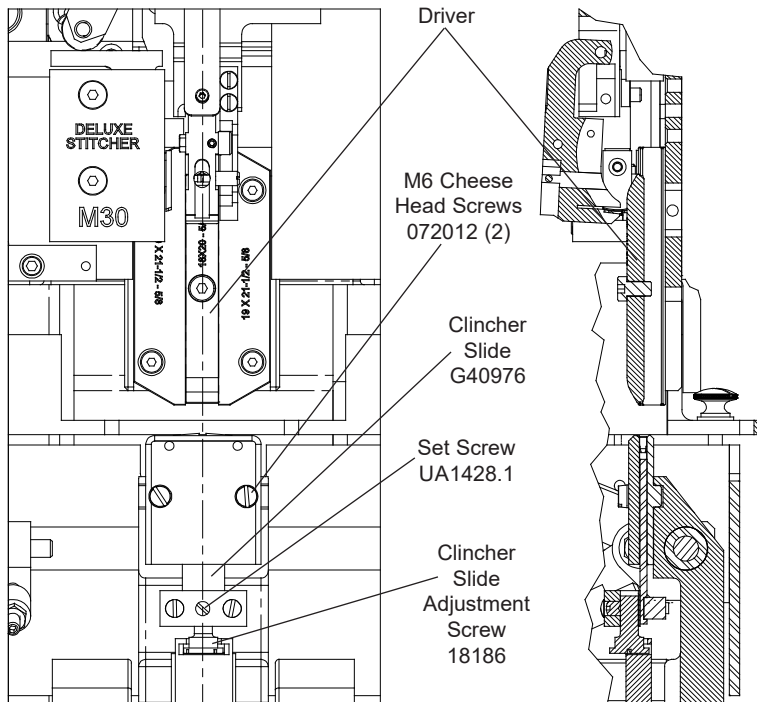

Figure 18 - Adjusting the Clincher

1. With the Work Table in the flat work position, check the clinch by manually cycling the machine to the point of clincher activation.
2. Loosen the Set Screw and rotate the Clincher Slide Adjustment Screw to raise or lower the Clincher Points. Once set, tighten Set Screw.
3. Complete the cycle and test. Repeat if necessary.

If clinching properly, but legs are misaligned:(See warning below)

4. Align the Driver & Clinchers by loosening the (2) Hex Head Cap Screws.
5. Manually cycle until until the Formers are near the top of the Clincher Plate. It is helpful to form a piece of wire so that it protrudes out past the Formers. (Best done when thickness is set to 1/4" [6mm])

Warning! This adjustment, if factory preset, should not be required unless Clincher Mounting is severely moved.

6. Move the Clincher Base Assy. until the front of Clincher Plate & Driver are centered and from the side the Former grooves and Driver are likewise. Tighten down when complete.

7. Very small additional adjustments are made by loosening the M6 Cheese head Screws and moving Clincher Plate to either side. This is method is employed primarily when Clincher Points have been changed to realign them with the Formers. (For left to right adjustment only.)

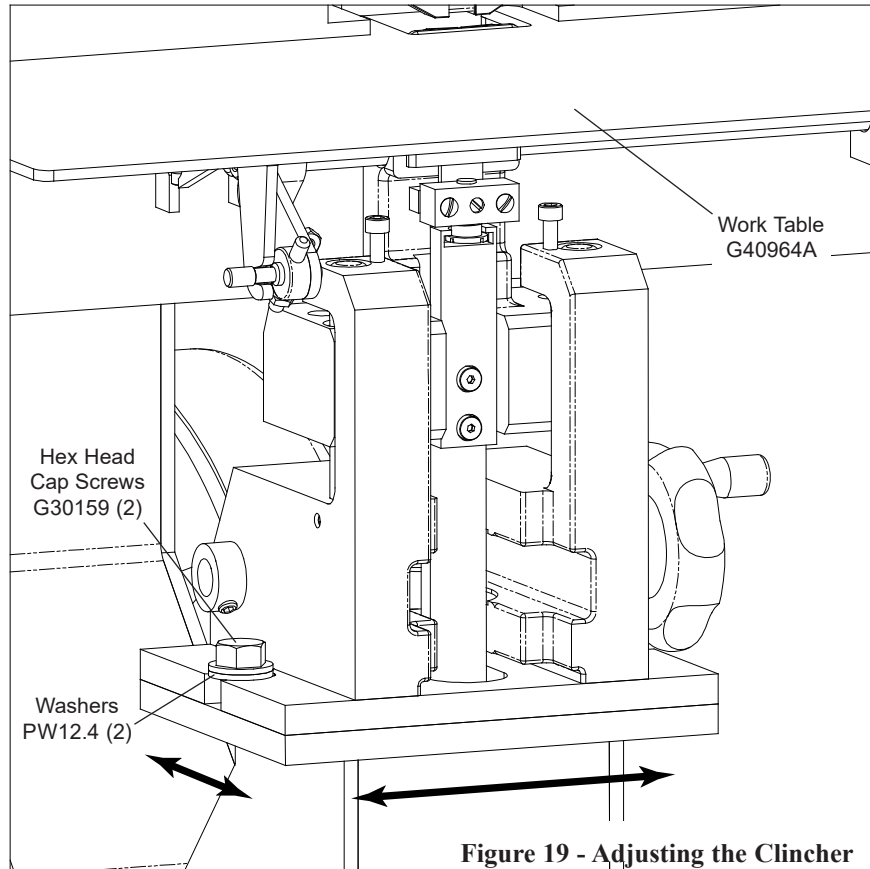

Figure 19 - Adjusting the Clincher

Always disconnect the power supply before making any adjustments or servicing the stitcher.

⚠ WARNING

Adjusting for Stab Stitching (Figures 20-21)

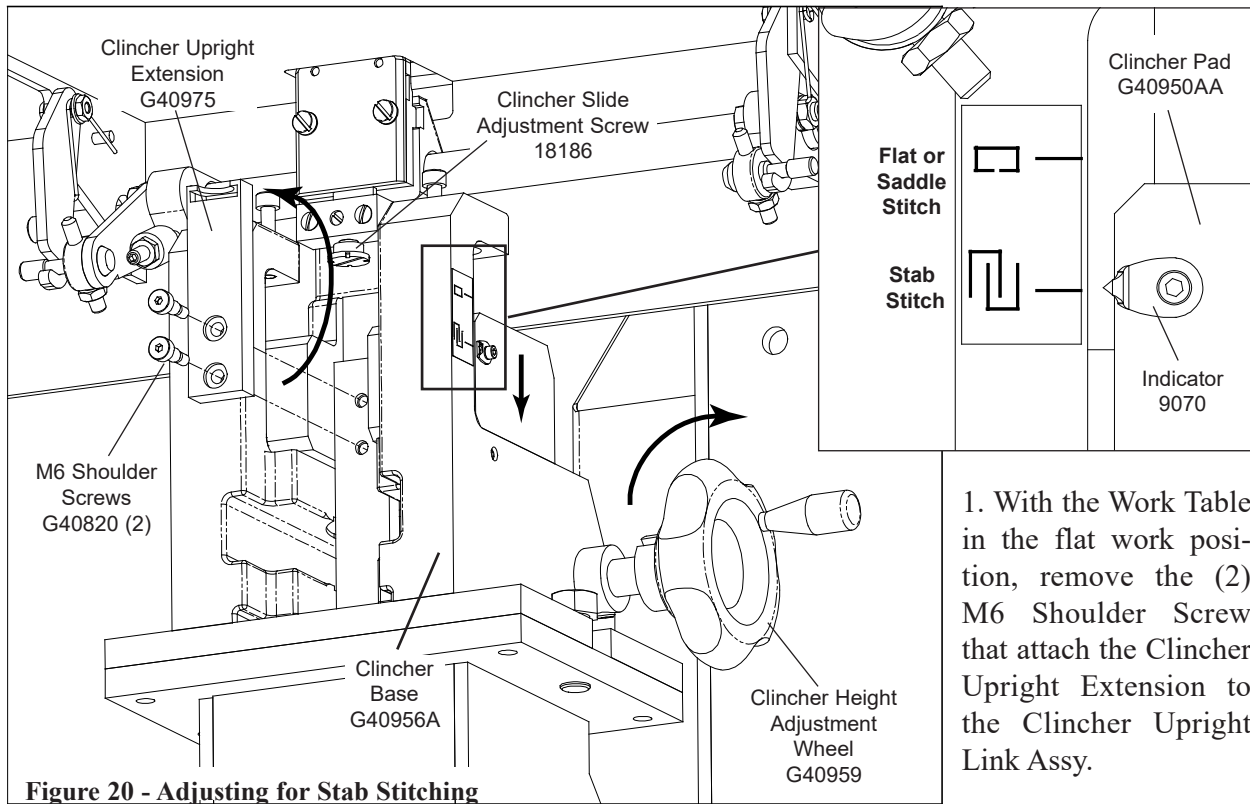

Figure 20 - Adjusting for Stab Stitching

1. With the Work Table in the flat work position, remove the (2) M6 Shoulder Screw that attach the Clincher Upright Extension to the Clincher Upright Link Assy.

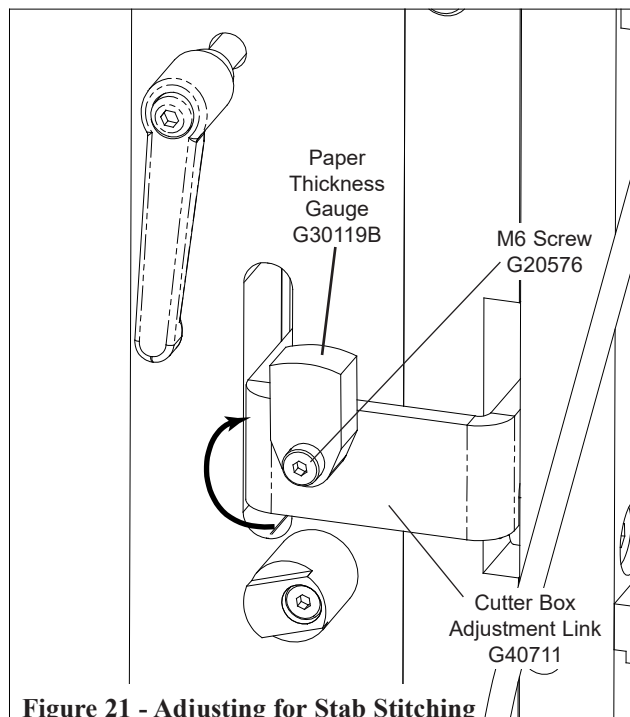

Figure 21 - Adjusting for Stab Stitching

2. Disengage from the Clincher Slide Adjustment Screw and remove the Clincher Upright Extension.

3. Rotate it 180° (left-right, not top-over) and reattach.

4. Now lower the Work Table to the Stab Stitch position by turning the Clincher Height Adjustment Wheel counter-clockwise until the Clincher Pad Indicator moves to the Stab Stitch position.

5. Lastly, loosen the M6 Screw of the Paper Thickness Gauge and rotate 180°, then retighten.

6. Work thickness must now be set without the benefit of the Paper Thickness Gauge and as described previously.

⚠ WARNING

FAILURE TO REMOVE Clincher Slide & Upright Extension will cause serious damage to stitcher not covered by the warranty.

Maintenance

FOR M30 MACHINES WITH SN STARTING FROM XXXXXX
 LOOK AT NEW WIRE STRAIGHTENER WITH
 NEW WIREGUIDE SPRING
 SEE PAGE 55 AND PAGE 57

Lubrication (Figures 22-23)

NOTE: Lubricate regularly instead of excessively.

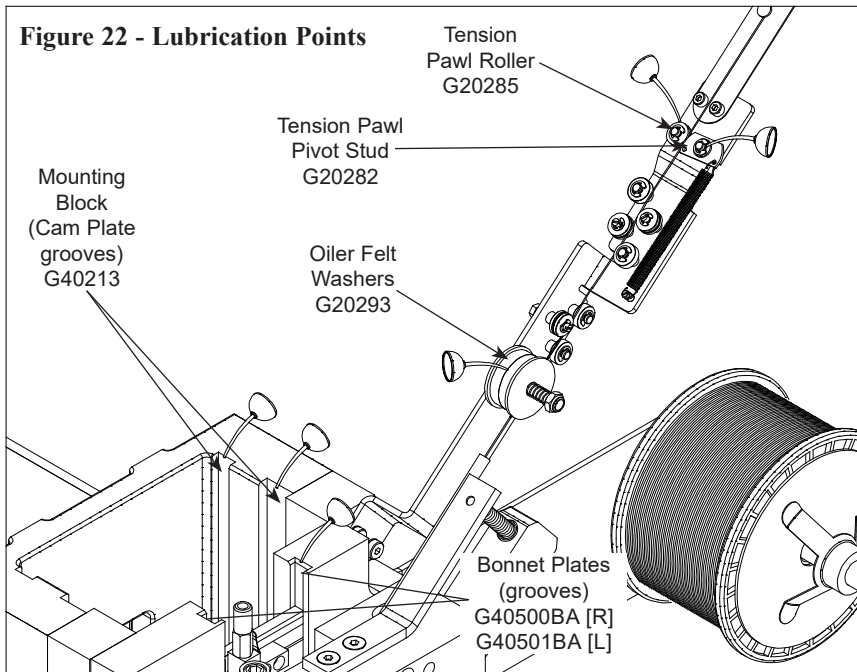

Thoroughly oil the Felt Washer and for all else, use only one or two drop of any standard S.A.E. #10 oil in the areas shown. Excessive oiling produces oil spotting in the work. Wipe any excess oil. Lubricate as follows:

1. In the the Mounting Block, the grooves for the Cam Plates and
2. the grooves for the Crank Housing Slide Plate Assy.
3. In the Bonnet, the grooves for the Driving and Bending Slides.

4. The outside of both Cutter Operating Lever Bearings.
5. Each side of the Driver grooves.
6. Both the upper and lower Pivot Studs for the Tension Pawl Rollers.
7. The front face of the Cutter Operating Slide.
8. The pivot slots in the Pivot Block for the Wire Holder.
9. The outside of the Feed Release Bearing.
10. The Cutter Operating Lever pivot area.
11. The Oiler Felts thoroughly.

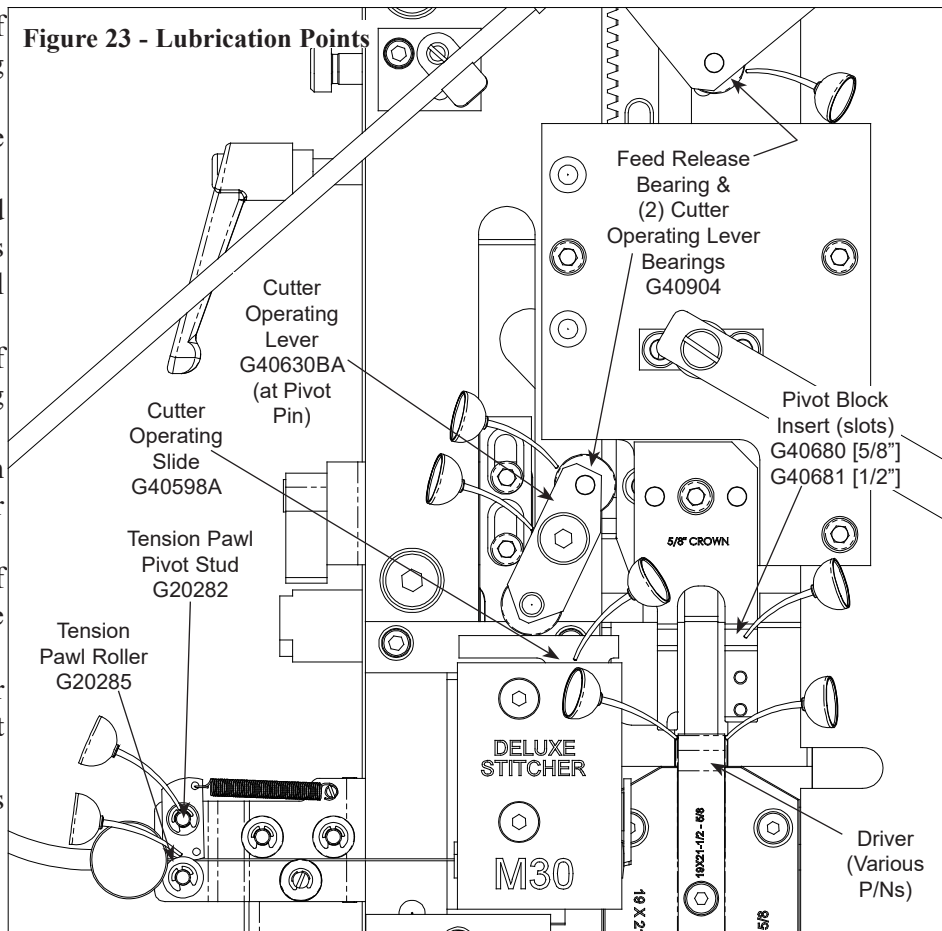

Troubleshooting (Figure 24)

The following is a brief list of problems and solutions which should cover the majority of situations encountered when stitching with the M30. The quality and quantity of work that can be produced with the M30 Stitcher is dependent upon the operator making all adjustments as accurately as possible and carefully maintaining the machine. The cause of staple imperfections usually can be traced to inaccurate settings or normal wear of moving parts. In the event of problems of this nature occurring, the operator can, by referring to the troubleshooting chart, quickly locate the solution.

PROBLEM: The machine will not complete a cycle, under power or manually.

SOLUTION:

1. Make sure the compression setting is correct. If not turn the Hand Wheel (G30128) counter-clockwise to raise the Stitcher Head.
2. If the V-Belt is too loose, it must be tightened.
3. Make sure none of the Clutch Springs are broken and that the Clutch has not failed. If either is the case, the entire assembly.
4. Make sure the Safety Interlock Key (850343) on the plastic Head Guard (G40135) is in complete contact with the switch on the right side of the head.

PROBLEM: The stitch quality is poor.

SOLUTION:

1. Make sure the wire is feeding straight from the Wire Spool and through the Stitcher Head.
2. Make sure the compression setting is correct.
3. Make sure the Clincher Plate (G40952A) is lined up with the Driver, both side-to-side and front-to-back.
4. Make sure the Clincher Points (G40955R or G40955F) are not set too low or too high.
5. Make sure the left leg of the stitch is the same length as the right leg.
6. Check the following Head parts for wear: the Cutters (G40145 & G40600), Driver, Formers, Supporter (G40653A), and Wire Holder (G20659BA). Reverse or replace worn parts as necessary.
7. Make sure the Clincher Points are clear of debris and paper build-up.
8. Make sure the Clincher Roller Bearing (G40905), located inside the frame, is not worn or broken.

PROBLEM: Wire is dropped before it can be formed, is drawn in inconsistent lengths, or is jamming.

SOLUTION:

1. Make sure the wire is feeding straight from the Wire Spool and through the Stitcher Head.
2. Make sure the Clincher Points are clear of debris and paper build-up.
3. Check the following Head parts for wear: the Cutters (G40145 & G40600), Driver, Formers, Supporter (G40653A), and Wire Holder (G20659BA). Reverse or replace worn parts as necessary.
4. Verify that the Wire Holder is properly aligned with the grooves in the Formers.
5. Make sure the Tension Spring on the Wire Spool is not set too tightly.
6. Make sure the Feed Gear Friction Plug is exerting enough pressure on the Large Feed Gear. (Between 3 & 4 turns after contact is made).
7. Make sure there is enough tension on the Feed Lever Spring.

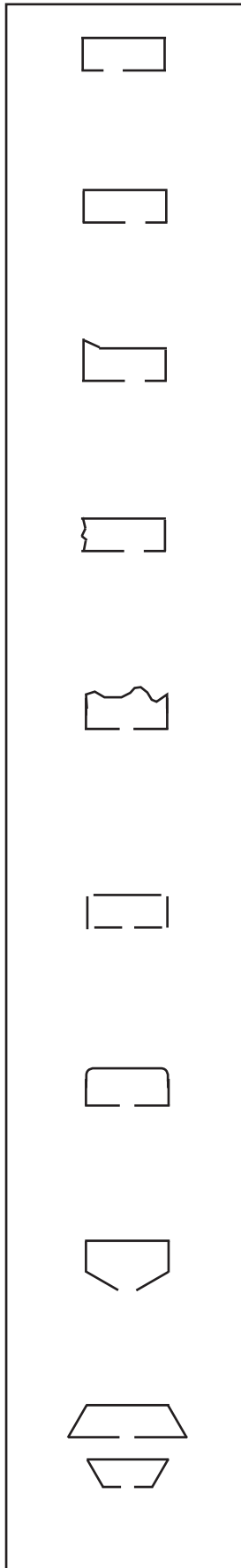

PROBLEM: Left Leg Short

SOLUTION: Lengthen the left leg by loosening the two screws on the Cutter Box Adjustment Slide, and moving the Cutter Box to the left.



PROBLEM: Left Leg Long

SOLUTION: Shorten the left leg by loosening the two screws on the Cutter Box Adjustment Slide, and moving the Cutter Box to the right.

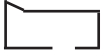

PROBLEM: Corner Buckled

SOLUTION: Check the Driver for a chipped corner and rotate or replace if necessary.

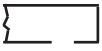

PROBLEM: Leg(s) Buckled

SOLUTION: Check the Wire Cutters for wear and rotate or replace if needed.

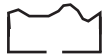

PROBLEM: Crown Buckled

SOLUTION: Check Supporter Spring tension. Check for correct wire size being used. Check for correct work thickness setting.

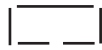

PROBLEM: Stitch in Pieces

SOLUTION: Clean the Wire Holder. If problem persists, file the forming corner of the Wire Holder slightly with a honing stone. Or replace the Wire Holder.

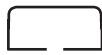

PROBLEM: Corners of the Crown are Rounded

SOLUTION: Replace the worn Wire Holder.



PROBLEM: Loose Clinch

SOLUTION: 1. Check for correct work thickness setting. Check and reset the Clincher Points height if necessary. Check Clincher Points and replace if worn. Check Clincher Slide and replace if worn.



PROBLEM: Legs are Spread or Contracted

SOLUTION: Readjust the Wire Straightener Eccentrics to improve straightness. Check the Wire Cutters for wear and rotate or replace if necessary. Check the Former grooves and replace if necessary.

Belt Guard Removal & Cycling Machine Manually / Adjusting the V-Belt (Figures 26-28)

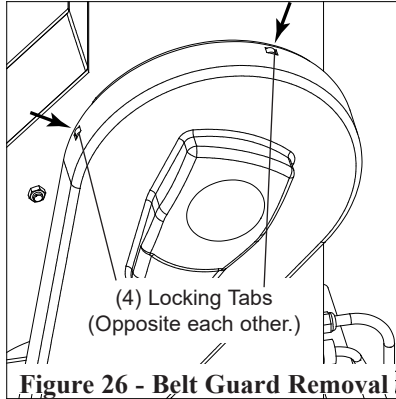

1. To remove the Belt Guard cover, push down on the (4) rounded tabs while pulling away the cover. Alternately, use a screw driver and pry away cover at or near the tab locations (Figs. 8 & 10). (For BST models, remove a securing screw first.)

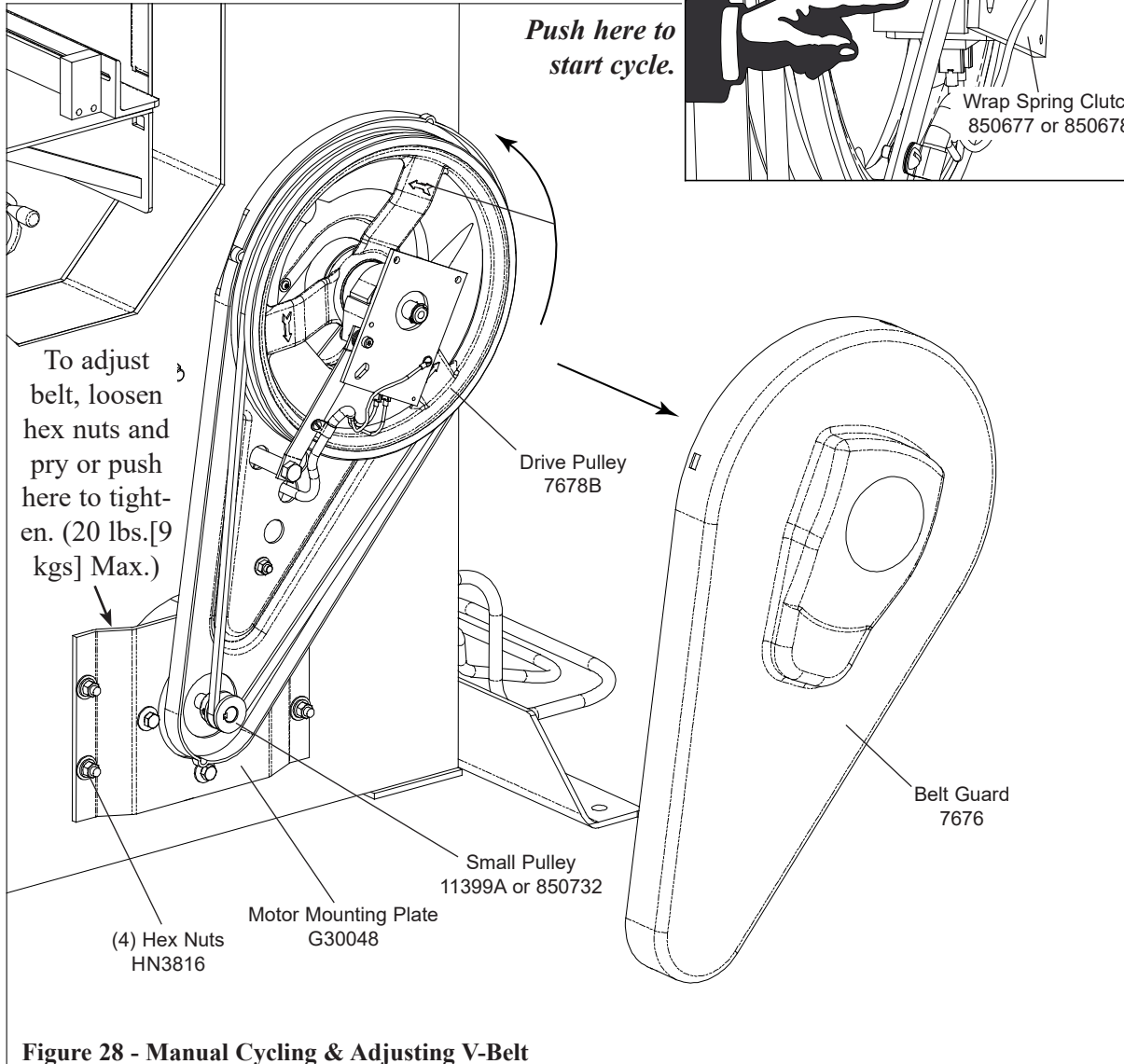
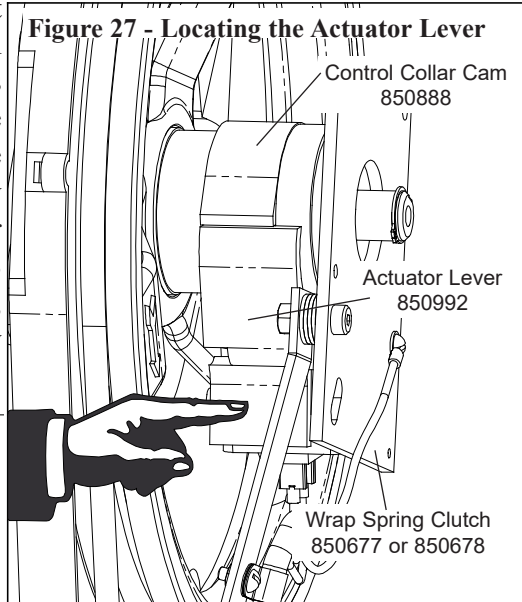

Figure 28 - Manual Cycling & Adjusting V-Belt

2. To manually cycle the machine, first locate the Actuator Lever on the Wrap Spring Clutch and push it where shown (in Fig 9) to pivot it away from the Control Collar Cam. Rotate Drive Pulley (as shown by the arrows on it, see Fig. 10) for one cycle. Repeat as necessary.
3. To tighten the V-Belt, loosen (do not remove) the (4) Hex Nuts on the Motor Mounting Plate. Use a screwdriver as a lever between the frame and the Mounting Plate to move it down slightly. Be careful not to shift the Small Pulley out of position.
4. Once taut, tighten the Hex Nuts.

Cleaning

In addition to proper lubrication, routine cleaning is important for the maintenance of the M30 Stitcher Machine. The entire head should be torn down and rebuilt every 250,000 to 500,000 cycles. The following areas should be cleaned once a month:

- **Large Feed Gear (G40510A)** remove and wash in an oil-dissolving solvent; dry and relubricate the clutch and bearings. Use Isoflex NBU 15 Bearing Grease
- **Anywhere that dust, oil or pieces of wire and paper have built up** - for example: around the Clincher Points and the Wire Straightener Rollers.
- **Blow Head and Clinchers off daily with compressed air.**

Head Disassembly (Figures 29 & 30)

1. Remove the Head Guard by lifting to disengage Safety Interlock Key.
2. Clear away all remaining wire and perform a full manual cycle.
3. Swing Wire Holder Retaining Spring clear and remove the Wire Holder.
4. Loosen Thumb Screw and remove Lower Wire Tube.
5. Remove the screws holding the Pivot Block and Feed Gear Bracket and pull away. The Feed Gear Bracket may require a slight pivot downward to remove.
6. Remove the Safety Interlock Switch followed by the Right Bonnet Plate Assy.
7. The Driving Slide and Bender Bar Assemblies can now be removed by sliding out to the right.
8. Remove the Cutter Operating Lever Assy., the Cutter Box Adjustment Slide and then the Left Bonnet Assy.
9. If mounted, remove the Wire Spool and then detach the Wire Spool Mounting Bracket.
10. Disconnect the Upper Wire Straightening Bracket Assy. and then remove the Left and Right Mounting Bars.
11. The Bender and Driver Cam Plate Assemblies can now be removed by pulling them forward and off the Crank Bushings.
12. Now remove the Cutter Operating Connecting Link, sliding it out the side of the machine.
13. Loosen the Set Screw securing the Crank Arm and pull it and the Key off the Head Drive Shaft.

**FOR M30 MACHINES WITH SN STARTING FROM XXXXXX
LOOK AT NEW WIRE STRAIGHTENER WITH
NEW WIREGUIDE SPRING
SEE PAGE 55 AND PAGE 57**

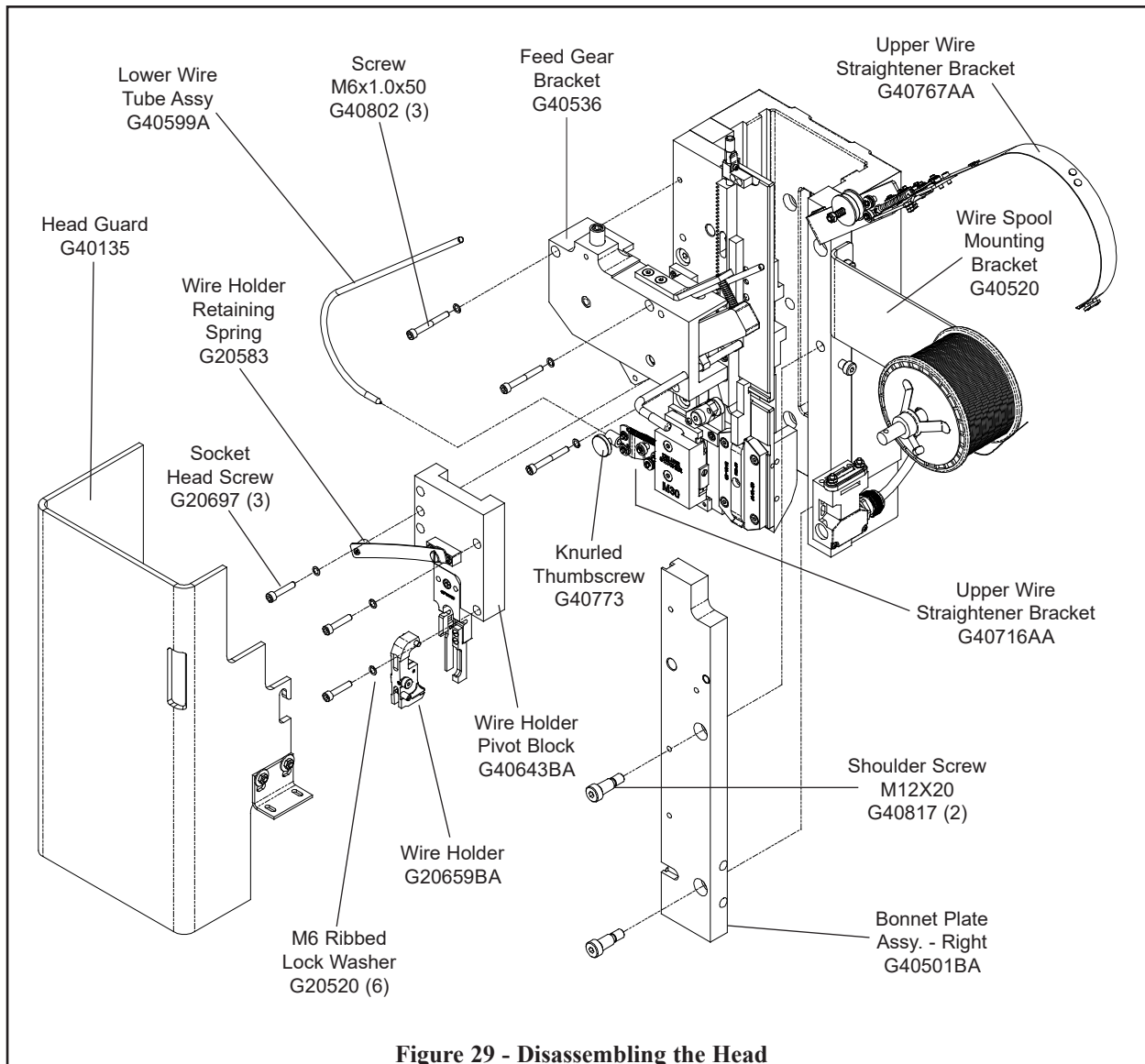
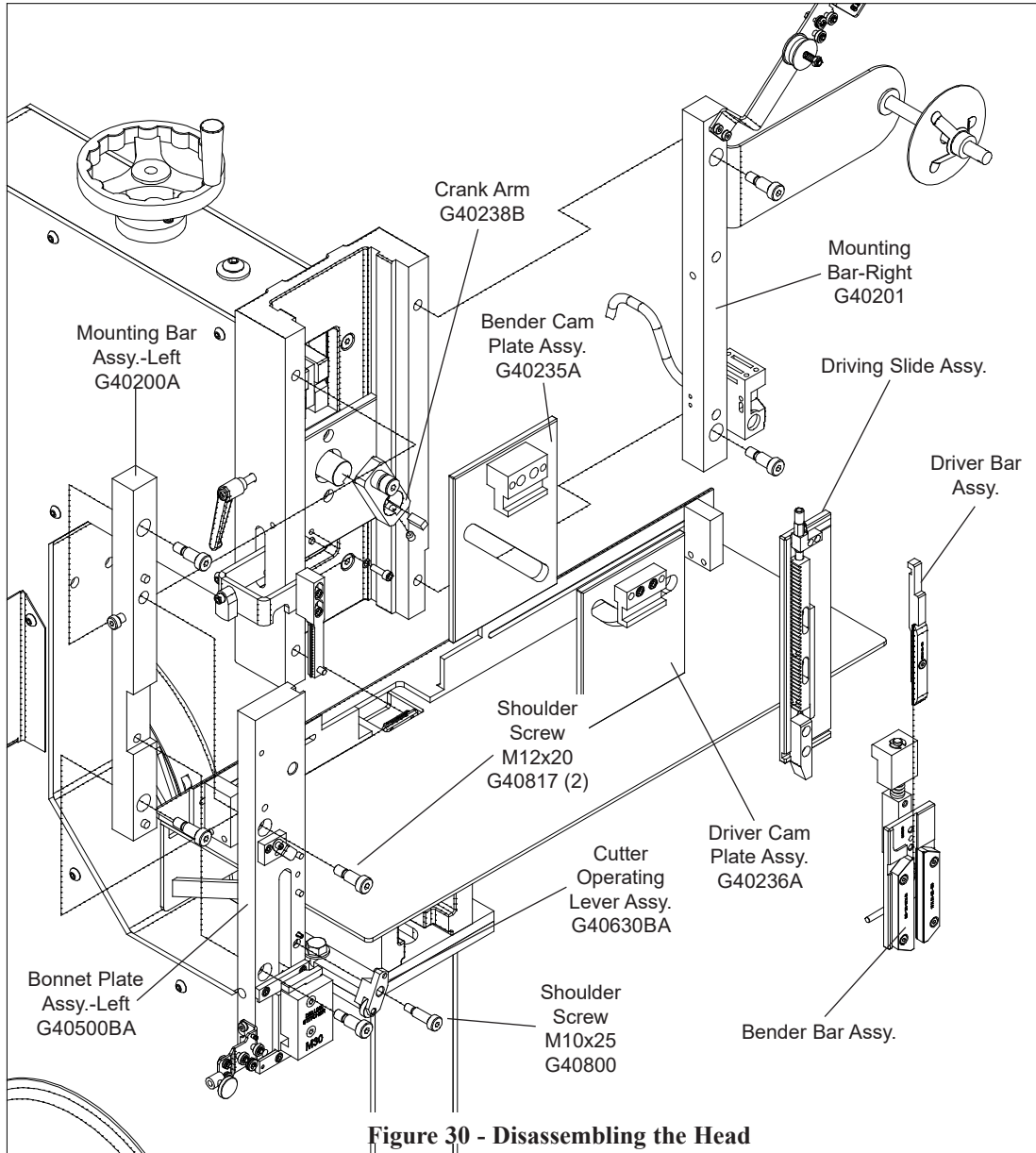

Figure 29 - Disassembling the Head

CAUTION: The Supporter is under tension and will spring out towards the front of the Head as these parts are removed. Keep fingers away from the Supporter to avoid injury.

⚠ WARNING

Always disconnect the power supply before making any adjustments or servicing the stitcher.



Ordering Spare Parts

In time, you will need to replace some parts in the M30 Stitcher Machine. To do this locate the DeLuxe Stitcher part number in one of the following diagrams and contact your Graphic Arts Representative to order the replacement by part number, description and quantity.

Replacing Spare Parts

The operator should periodically inspect all moving parts for signs of wear and when required, replace the worn parts. The following are some of the more common wear parts which will need to be removed and replaced in your M30 as well as step-by-step instructions to replace them.

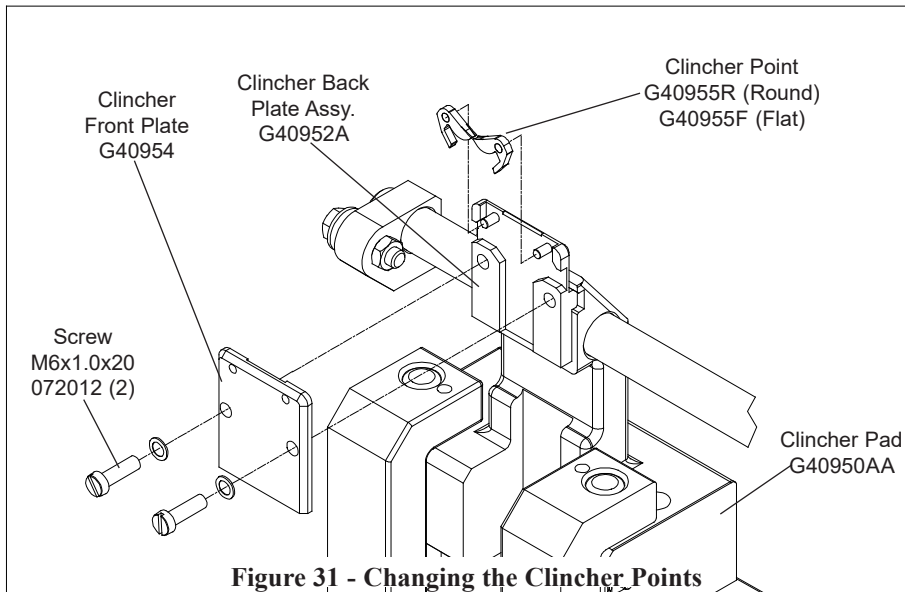

Figure 31 - Changing the Clincher Points

Removing and Replacing the Clincher Points and Clincher Slide

The Clincher Points are not reversible as with other styles, but are easy to replace.

1. Free the entire Clincher Plate Assy. with the Clincher Slide by removing the screws securing it to the Clincher Pad.

2. Lift off the Clincher Front Plate to reveal the Clincher Points.
3. Remove the worn Clincher Points.
4. To replace the Clincher Slide, loosen the two Clincher Slide Block Screws that connect the Clincher Slide Block Clamp to the Clincher Slide Adjustment Block.

6. Remove the old Clincher Slide and replace with a new one.

7. Retighten the Clincher Slide Block Screws.

8. To replace the Clincher Points, slide the new ones over the pins in the Clincher Back Plate Assy. making sure the large radius on the Points rests on the top of the Clincher Slide.

9. Replace the Clincher Front Plate.

10. While holding the entire assembly, move the Clincher Slide up and down a few times to ensure everything is moving freely and does not lock up.

11. Reattach the Clincher Plate Assy. to the Clincher Pad making sure the bottom of the Adjustment Screw rests in the cutout of the Clincher Upright Extension.

12. Insert the screws and lock washers and tighten.

13. Check the alignment of Clincher Plate Assy. with the Formers and adjust if necessary.

14. Cycle the machine manually to ensure the Clincher Point height prior to beginning work.

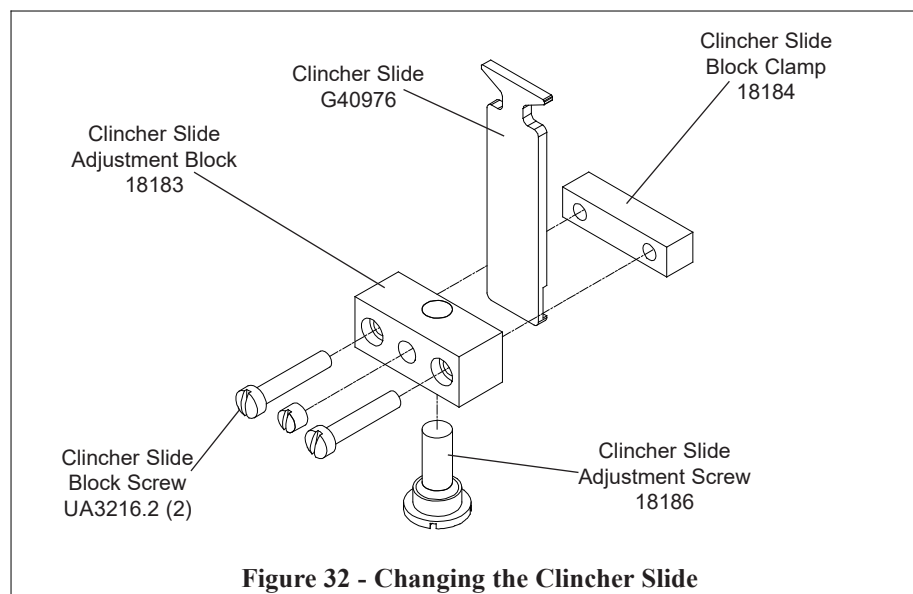

Figure 32 - Changing the Clincher Slide

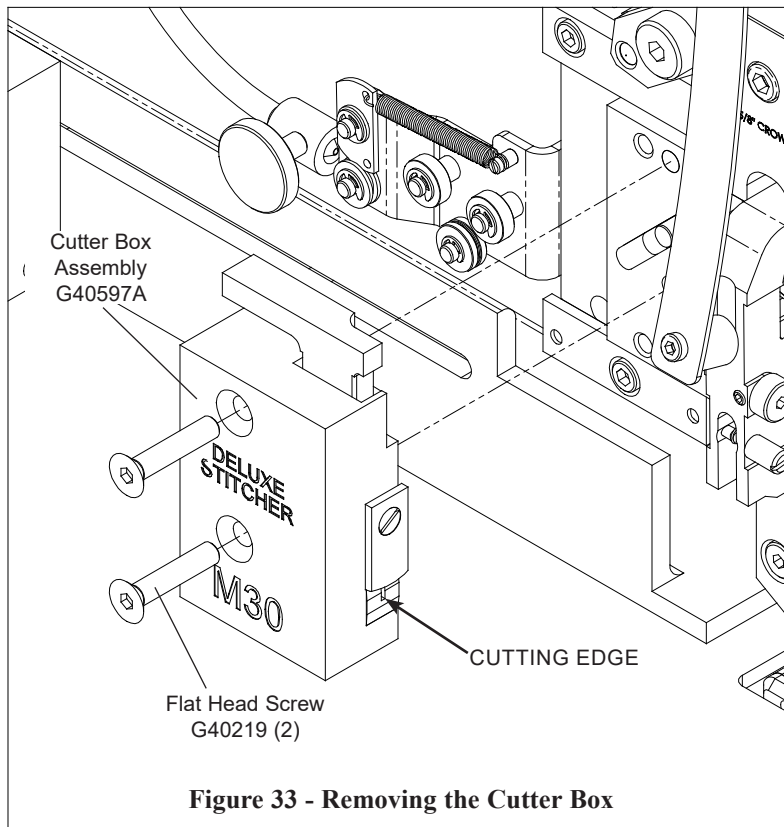

Figure 33 - Removing the Cutter Box

that a new cutting edge will cut the wire and then tighten the screw. (To prevent the Cutter from spinning as you tighten, rest the side of the Cutter on a flat surface and while holding the Cutter Operating Slide, tighten the screw.

Fixed Cutter

4. To replace the Fixed Cutter, loosen the Set Screw below it and be wary of the Cutter Operating Spring, pull it out along with the Cutter Operating Slide.

5. Separate and retain all the other parts, replacing only the worn Fixed Cutter with a new one.

6. Reassemble all the parts and place them back into the Cutter Box. The spring will have to be compressed while doing this. Also ensure that the Wire Hold Down settles in the groove of the Fixed Cutter.

7. Adjust the Fixed Cutter by holding down the Cutter Operating Slide in the cutting position and lightly push the Fixed Cutter against the Moving Cutter. Tighten the Set Screw and release the Slide and then push the Slide down a few times to ensure free movement.

8. Replace the Cutter Box Assy.

Adjusting and Replacing the Cutters

Cutters become worn or chipped and must be adjusted or replaced. The Fixed Cutter must be replaced when worn. The Moving Cutter can be adjusted 3 or 4 times before needing replacement. To adjust or replace Cutters:

1. Remove the Cutter Box Assy as shown in Fig. 33.

Moving Cutter

2. To adjust the Moving Cutter, first remove the Cutter Operating Slide. **Note: The Cutter Operating Spring is compressed, take care when removing the Cutter Operating Slide.**

3. Loosen the screw holding the Moving Cutter, rotate the Cutter so

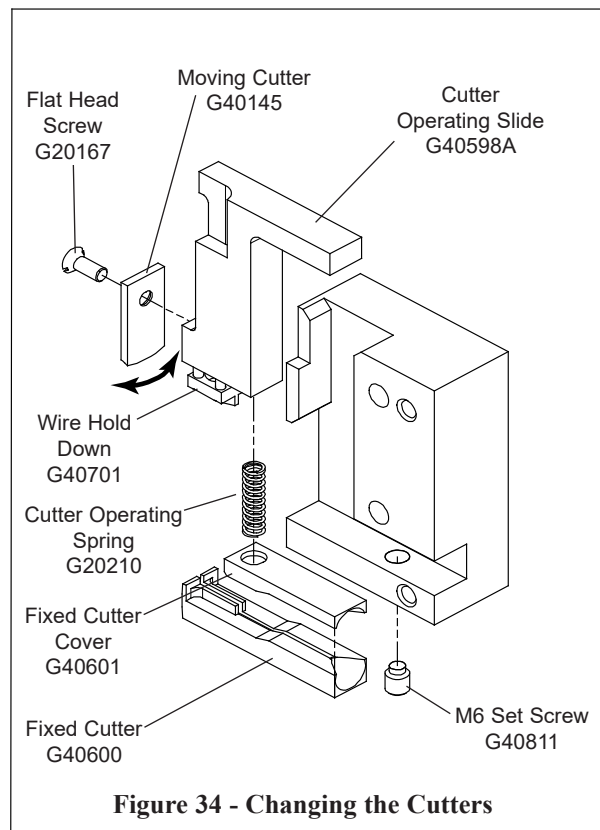

Figure 34 - Changing the Cutters

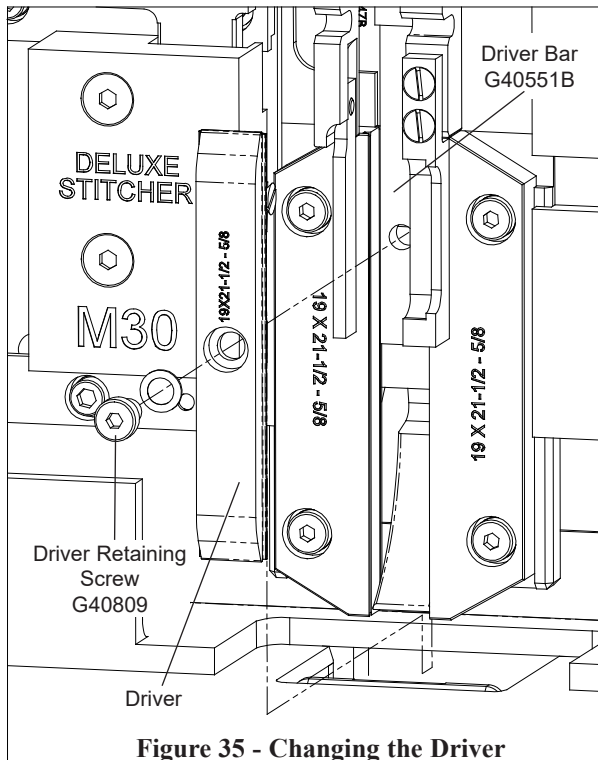

Figure 35 - Changing the Driver

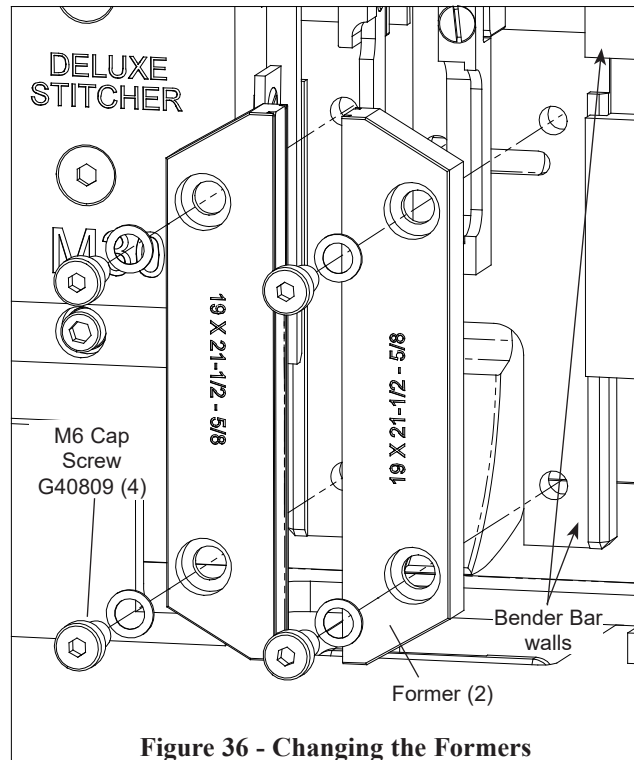

Figure 36 - Changing the Formers

Replacing the Formers & Driver

The Driver and Formers must be replaced when worn or when changing wire size. Replace them as follows:

1. Unlock the Hand Wheel by turning the Adjuster Lock Lever counter-clockwise and raise the Head to its highest position by turning it counter-clockwise..
2. Swing aside the Wire Holder Retaining Spring and remove the Wire Holder Assy.

Driver Only

3. Remove the Driver Retaining Screw and the Lock Washer. It will now slide out of the Head.
4. Slide the new Driver up the Former grooves until it stops against the Driver Bar and fasten.

Formers

5. After removing the Driver, remove the four Screws and Lock Washers and to separate the Formers from the Bender Bar.
6. Replace with new Formers by pushing them up and to the side against the walls of the Bender Bar as pointed out in Fig. 36. Reattach with Formers and Driver with aforesaid screws and washers, keeping the Driver just short of fully tightened..
7. Manually cycle the Machine two or three times to set the Formers, then fully tighten the Driver. Manually cycle again to ensure free movement of everything.
8. Return the Head to its appropriate position and lock by turning both the Hand Wheel and Lock Lever clockwise.

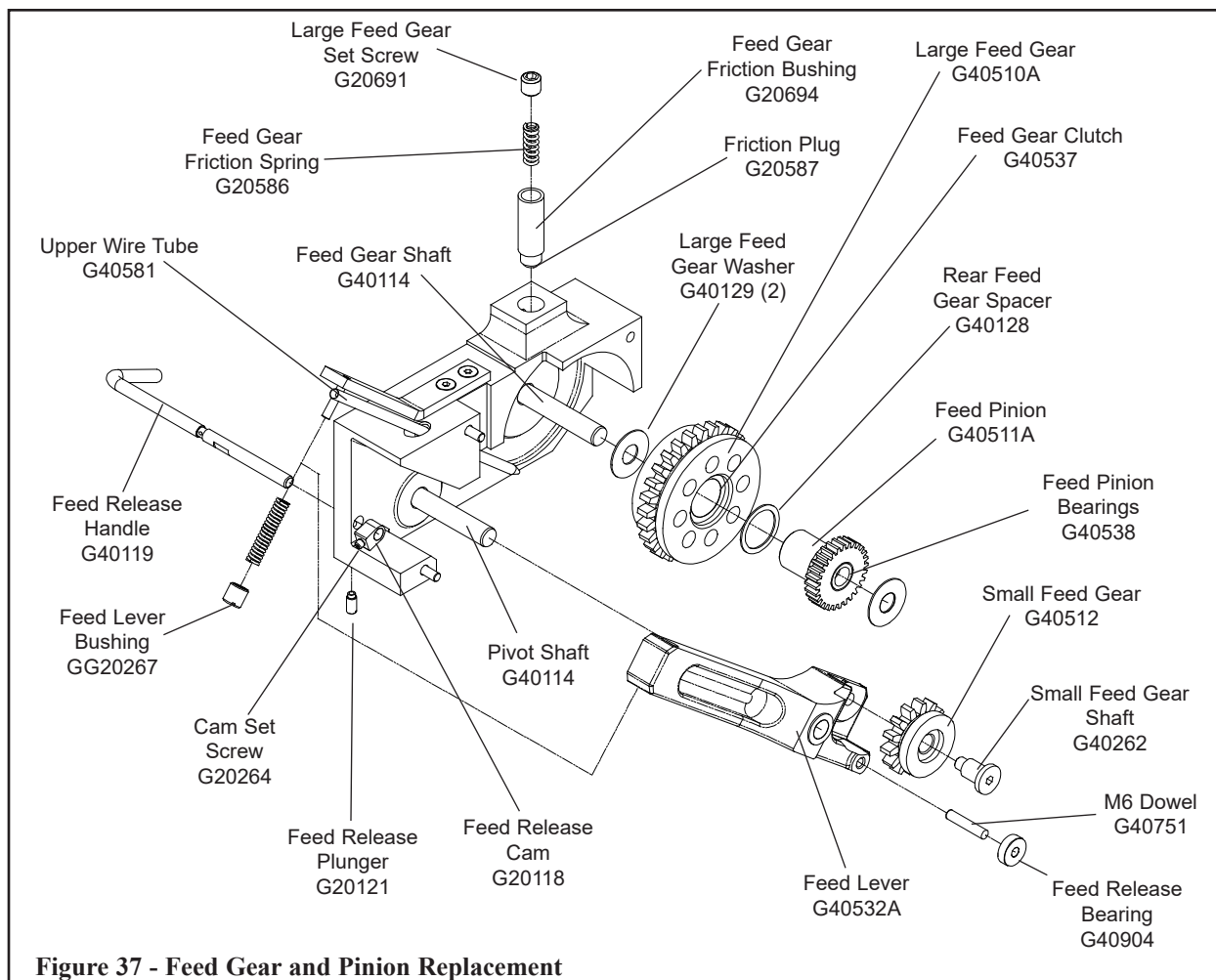

Feed Gears and Feed Pinion Replacement

1. Remove Feed Gear Bracket Assy. as previously instructed and turn the Feed Release Handle so that the Set Screw in the Feed Release Cam is accessible. Loosen and remove the Cam from the Feed Release Handle.
2. Loosen the Feed Release Plunger and remove the Feed Release Handle.
3. Unscrew the Feed Lever Bushing from the Feed Lever and remove the Feed Lever Spring. (If necessary, the Upper Wire Tube can be removed after loosening the M6 Set Screw (G20522) securing it.)
4. Lay the Feed Gear Bracket flat on its front. The Feed Lever Assembly can be removed by pulling it up off its Pivot Shaft.
5. To remove the Small Feed Gear, unscrew and remove the Small Feed Gear Shaft from the Feed Lever.
6. Remove the Feed Release Bearing by pressing the Bearing and M6 Dowel out of the Feed Lever. Press the Bearing off the Dowel and press a new Bearing on the Dowel. Press the new Bearing and Dowel back into the Feed Lever.
7. Replace the Small Feed Gear and screw in the Small Feed Gear Shaft using a thread locking compound, being careful not to get any compound on the surface upon which the Gear rides.
8. To remove the Large Feed Gear loosen and remove the Set Screw in the Feed Gear Friction Bushing to relieve the pressure the Feed Gear Friction Plug is placing on the Feed Gear. Remove the Friction Plug and the Feed Gear Friction Spring from the Bushing. Check them wear and replace if necessary.

9. Lift the top Large Feed Gear Washers, the Large Feed Gear and the Feed Pinion off the Feed Gear Shaft and away from the Feed Gear Bracket.
10. Remove the Feed Pinion and Rear Feed Gear Spacer from the Large Feed Gear. If necessary, liberally apply Kluber ISOFLEX NBU 15 grease to the Feed Pinion Bearings and/or the Feed Gear Clutch and rub into the rollers using your finger and reassemble.
11. Replace the Feed Lever Assembly and if necessary the Upper Wire Tube. Insert the Feed Gear Friction Plug in the Feed Gear Friction Bushing. Apply any Lithium-based grease to the Feed Gear Friction Spring and insert it into the Bushing. Tighten the Set Screw, over the Spring, 3 to 4 turns after contact is made. The Feed Release Handle and Cam can be installed after the Feed Gear Bracket is re-attached to the Machine.

Bender Bar Disassembly

To begin disassembly of the Bender Bar Assembly (G40547BA):

1. First, if the Driver Bar and Formers are still attached, remove them now (Figs. 35 & 36)
2. Remove the Supporter Assy. by pushing the top of it forward and pushing the M5 Dowel Pin out towards the right.

CAUTION: Be very careful separating Supporter Assy. from the Bender Bar. The Supporter and Supporter Plunger are under pressure from the Supporter Spring and can shoot out of the Supporter.

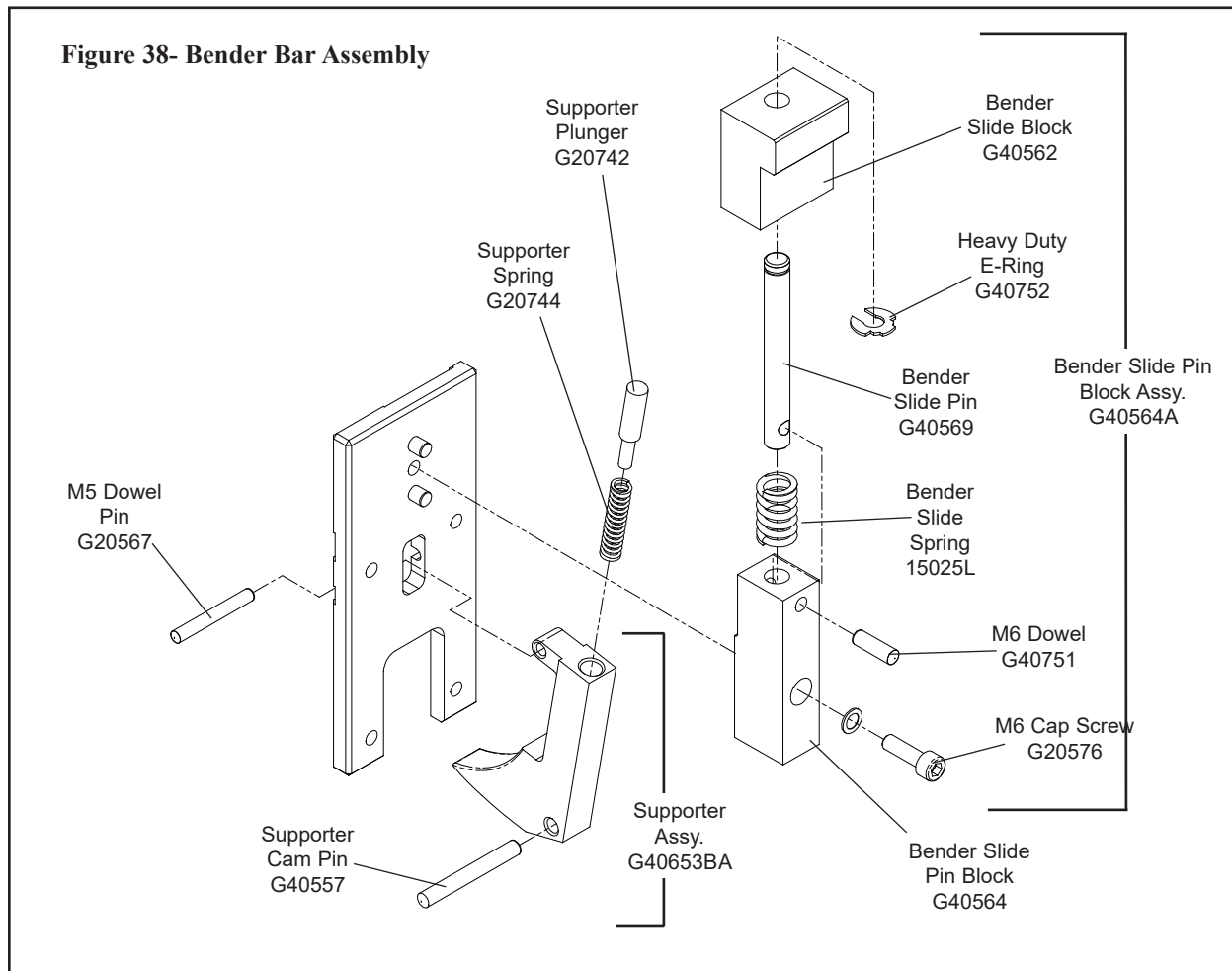

3. Push the M6 Dowel out the right side of the Supporter.
4. Remove the Bender Slide Pin Block Assy. from the the Bender Bar.
5. To disassemble the Bender Slide Pin Block Assy., place it in a vise. Clamp the bottom of the Bender Slide Pin Block and the top of the Bender Slide Block. With clearance left for it, pry off the E-ring with a screwdriver, and carefully unclamp the Bender Slide Pin Block Assy.

CAUTION: The Bender Slide Pin Block Assembly is under tension from the Bender Slide Spring.

6. Lift the Bender Slide Block off the Bender Slide Pin and remove the Bender Slide Spring. The Bender Slide Pin can be removed from the Bender Slide Pin Block by pressing the M6 Dowel out of the Block.

Driving Slide Disassembly

Begin disassembly of the Driving Slide Assembly (G40531BA) by:

1. Removing the M6 Cap Screw and Lock Washer (G20520) securing the Feed Slide Block.
2. Remove the Cutter Operating Cam from the Driving Slide and then the Rack Assembly by removing the Feed Rack Guide and M4 Cap Screws

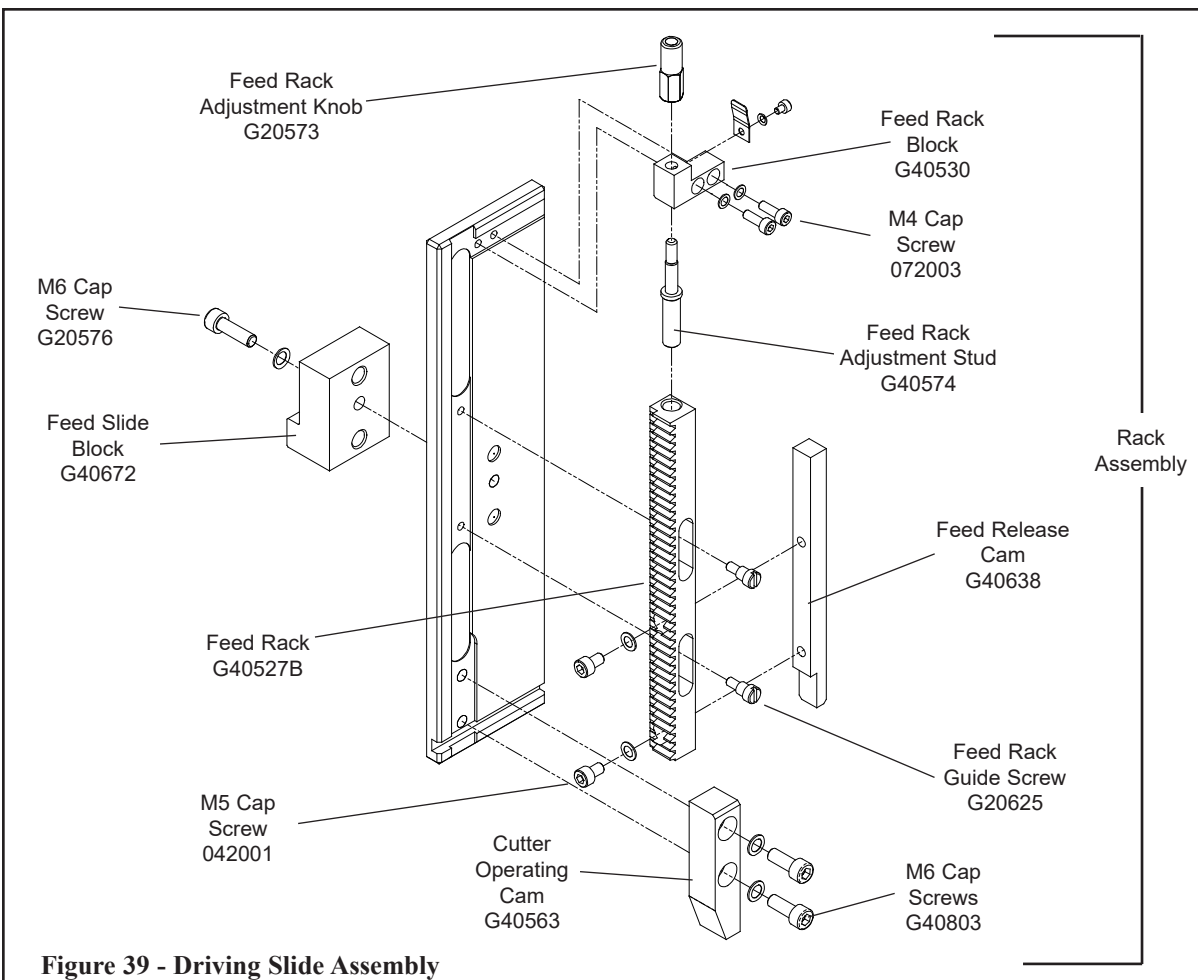

Figure 39 - Driving Slide Assembly

3. Remove the Feed Rack by holding the Feed Rack Block and turning the Feed Rack Adjustment Knob counter-clockwise until the Rack comes off the Feed Rack Adjustment Stud.
4. Remove the Feed Release Cam (G40638).

Do not operate the M30 under power until the machine has been turned over manually to verify that the stitching head is operating freely.



Clutch-Brake Maintenance

⚠ **WARNING**
Always disconnect the power supply before making any adjustments or servicing the stitcher

This stitcher is equipped with a solenoid actuated, continuous trip, wrap spring clutch-brake unit. It is a dependable device and seldom needs service. But should a malfunction occur, the following information is a service and troubleshooting guide for the maintenance of this unit.

Actuator

The actuator is a simple, straight-forward mechanical linkage. When the actuator does not trip, the following checks should be made. Refer to **Figure 40** for more details.

<u>Problem</u>	<u>Cause and Remedy</u>
No power to the Coil.	Check all wiring and switching in the Clutch actuating system.
Lack of continuity in the Coil Windings.	Replace the Coil. (850998 - 230 VAC or 850999 - 115 VAC)
Mechanical binding of the Plunger.	The Coil may have shifted or the Plunger end may have mushroomed due to striking the Backstop. In the latter the Plunger may be filed to its true diameter.
Insufficient clearance for the Actuator over the Stop Collar.	Adjust the Linkage as needed.
Actuator loaded by the Stop Collar so hard that the Actuator cannot be pulled by the Coil.	Braking force is exceeding the limits of the Brake or the Differential setting of the unit is too close. (see Figure 30 for instructions)
Figure 40 - Actuator Checklist	

Clutch and Brake Springs

With the brake engaged (full limit of output), the input hub should be free to rotate by hand. With the clutch engaged, the input and output hubs should rotate together. If the unit does not rotate in either of these modes, the clearance between the hubs of the unit on the shaft may have been disturbed or damaged. See Assembly/Disassembly instructions for re-adjusting.

Listed below are additional checks to be made if the clutch does not function correctly. Refer to **Figure 41** for details.

<u>Problem</u>	<u>Cause and Remedy</u>
Clutch Brake does not drive but Input Motor turns.	<ol style="list-style-type: none"> 1. Drive Spring (850889) may be broken at the cross-over point from an overload caused by a jam. Replace the Spring and check the Hubs (851321 or 850892) for damage. 2. The Control Collar (850888) may not snap forward because of foreign matter restricting movement. Clean unit. 3. Actuator Assembly does not pull in. (Figure 28)
Clutch Brake jams and stalls the Input Motor.	<ol style="list-style-type: none"> 1. Spring tang broken off Drive Spring not allowing the Clutch to disengage while the Brake is engaged. Replace the Drive Spring. 2. Clutch output is bound up. Check the clearance between the Output Hub and the Brake Hub. 3. Completely out of adjustment caused by losing an internal Spring tang. Replace Spring.
Output does not repeat stopping point	<ol style="list-style-type: none"> 1. Not enough inertia to actuate Brake. 2. Tang broken off the Brake Spring. Replace the Spring. 3. Adjustable Collar Locking Screw may be loose allowing Adjusting Screw to rotate.
Figure 41 - Clutch and Brake Spring Checklist	

Disassembly (See figure 42)

To disassembly the Clutch-Brake unit (850673 or 850674) it will be necessary to remove the Drive Pulley (7678) from the stitcher by removing the V-Belt (850730), Retaining Ring (P7863), and Clutch Anchor Screw (7681). Disconnect the Ground and Solenoid wires, and swing the anchor strap (FC9656) clear of the Drive Pulley Assembly and slide it off of the Drive Shaft. Remove the three (3) Screws (UA4812.7) connecting the Drive Pulley to the Clutch-Brake unit.

When disassembling the Clutch-Brake unit, always mark the Spring Tang locations with reference to which slots they go in if the same Springs are to be used for reassembly. To disassemble the Clutch-Brake unit, proceed as follows:

Release the Actuator Lever so that the Clutch is engaged and the Brake is released. Remove the Retaining Ring and the Shim Washer, if any, from the Input Hub (851321) end. Remove the Input Hub by rotating opposite to the drive direction. Remove the Retaining Ring and the Shim Washer, if any, from the Mounting Plate end.

Remove the Output Shaft Springs and the Control Collar (850888) Assembly by rotating the Output Shaft (850891) in the drive direction. **(Do not disassemble the brake Hub (850892) from the Mounting Plate. (850890))** Remove the Control Collar from the Output Shaft and the Spring Assembly by extracting toward the Brake Spring end.

Assembly (See figure 42)

Replace the Clutch (850888), Brake (850889) and Anti-Back (850962) Springs as required. Assemble the Springs concentric and square to the Output Shaft.(850891) Assemble the Control Collar over the Output Shaft and Spring Assembly by inserting it from the Brake Spring End (it will be necessary to extend the Brake Springs using long nose pliers.) Place the Brake Spring Tang in any one (1) of the nine (9) Control Collar slots at random.

Assemble the Output Shaft, Springs and Control Collar assembly to the Mounting Plate Assembly by rotating the Output Shaft in the drive direction. Assemble the Retaining Ring (850886) to the Output Shaft at the Mounting Plate end (the smooth surface facing the Brake Hub.) Check the end play between the Hub and the Retaining Ring with a feeler gauge. There should be 0.004” to 0.010” end play. Use a Shim Washer to adjust if necessary.

Rotate the Output Shaft in the drive direction until it reaches a full brake position. With the Clutch Spring Tang **NOT** in slot, insert the Input Hub (851321) by rotating opposite to the drive direction. Select one (1) of ten (10) Control Collar slots for the Clutch Spring Tang that will provide a 0.38” to 0.50” circumferential overtravel of the Control Collar when released.

Note: At this point it may be necessary to reselect one (1) of the nine (9) Control Collar slots for the Brake Spring Tang (release Actuator Lever, remove the Clutch Spring tang from the slot, then move Control Collar axially toward the Input Hub end and rotate it opposite to the drive direction to pick up the next slot). Continue to select Control Collar slots until the 0.38" to 0.50" specification is achieved.

Assemble the Retaining Ring to the Output Shaft at the Input Hub end (the smooth surface facing the Input Hub). Check the end play between the Input Hub and the Retaining Ring with feeler gauge. There should be 0.002" to 0.003" end play on the Input Hub.

Reassemble the unit to the machine.

Note: After the Clutch is assembled to the machine, the Clutch Plate should be free to float on bearing - the Anchor Strap is only there to prevent rotation of the plate.

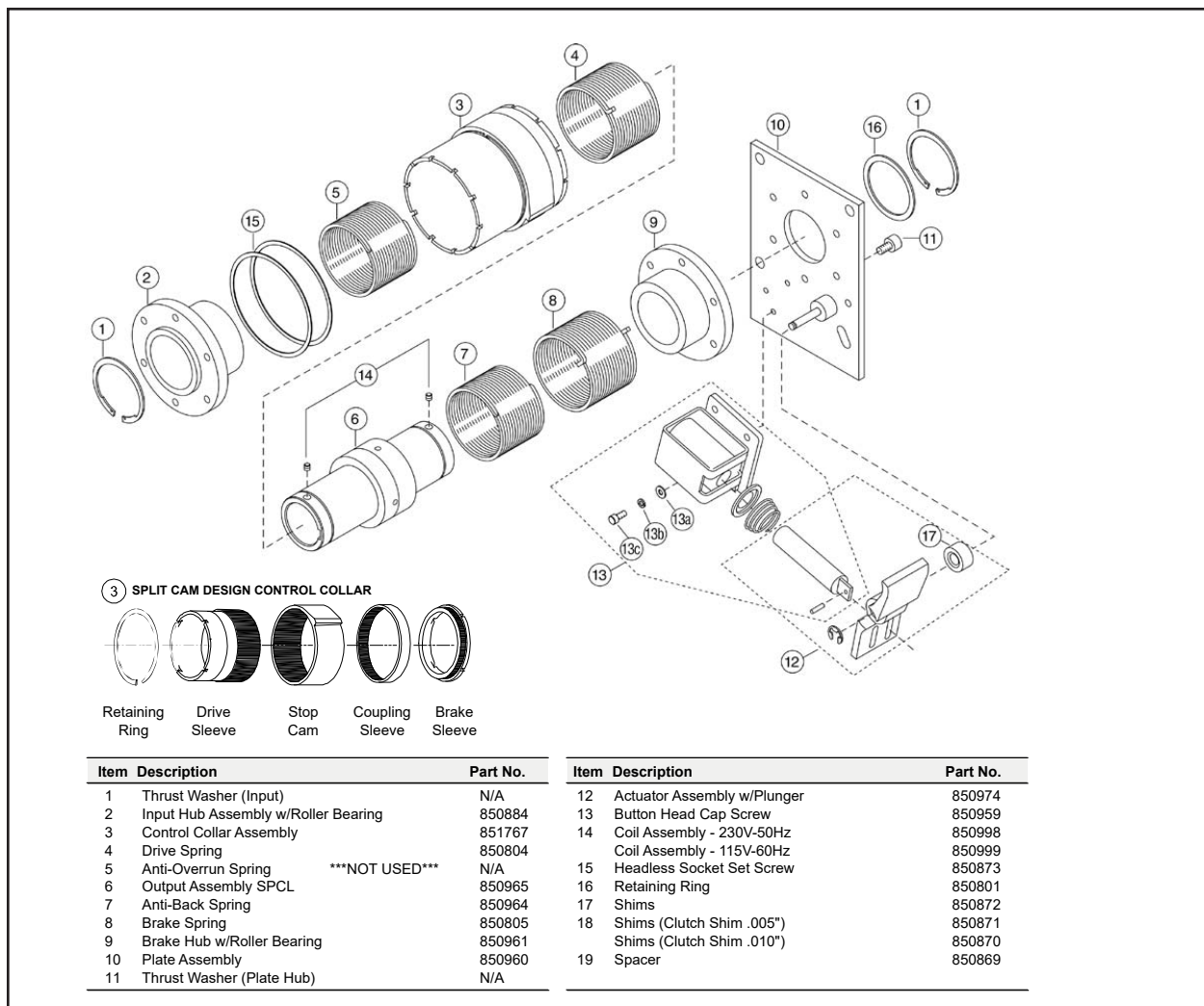

Figure 42 - Clutch - Brake

Lubrication

The clutch-brake unit is designed with the bearing parts made from sintered metal that has been impregnated with oil and normally do not need to be re-lubricated. In cases where there is severe duty, the unit may be re-oiled or flushed out with minimal or no disassembly by using a light bearing oil as used in manufacture (Shell Bearing Infusion Oil #33). If disassembly of the unit for cleaning and oiling is necessary, follow the detailed disassembly instructions to the point needed, flush and wipe parts in the oil to be used for re-lubrication. **Do not use solvents** to clean the parts. To get more cleaning action for the oil, it may be heated while cleaning the components, but bring the parts back to ambient temperature submerged in cool oil.

Coil Replacement

Place the spring onto the plunger with the narrow end towards the actuator. Slide the solenoid onto the actuator and plate assembly. Assemble the solenoid to the plate assembly with the cap screws and washers. **Do not tighten** more than finger tight.

Energize the coil and adjust the gap between the actuator and the top of the collar stop to 0.015" to 0.030" by sliding the solenoid assembly. Note: push the collar toward the actuator to allow for collar movement. Tighten the cap screws.

Control Collar Adjustment (Figure 43)

The stopping position of the head can be changed if necessary by adjusting the position of the stop cam on the control collar sleeve. Turn the machine manually until the driver is in the desired stopping position, then proceed as follows:

Work the Retaining Ring (850886) out of its groove and slide it forward on the Input Hub (851321). Slide the cam of the Control Collar Assembly (850888) off of the splines, rotate to align the collar stop with the actuator and slide the cam back on the splines. The actuator pawl will have to be held clear during this operation. Slide the retaining ring back into its groove.

Make sure brake is locked up before proceeding, to insure the proper stop point.

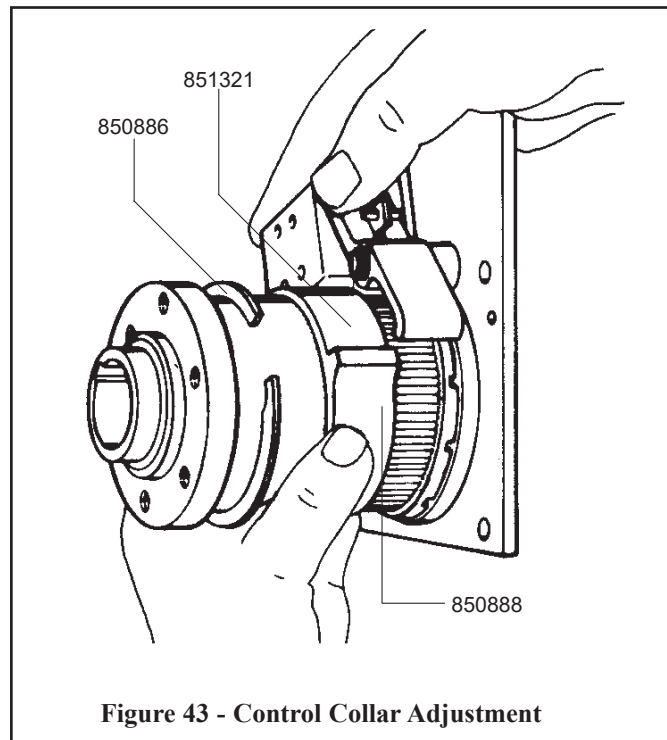
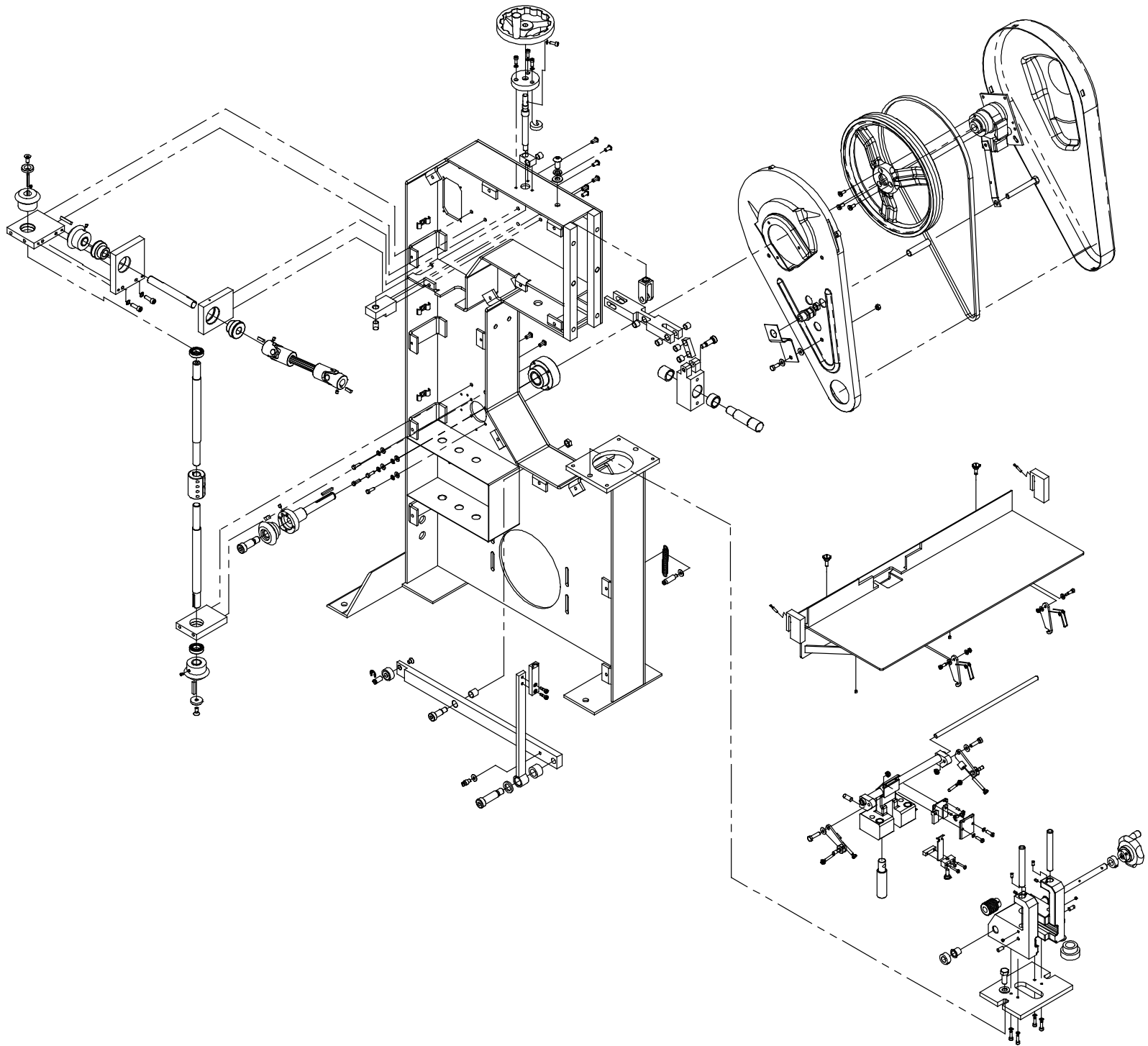
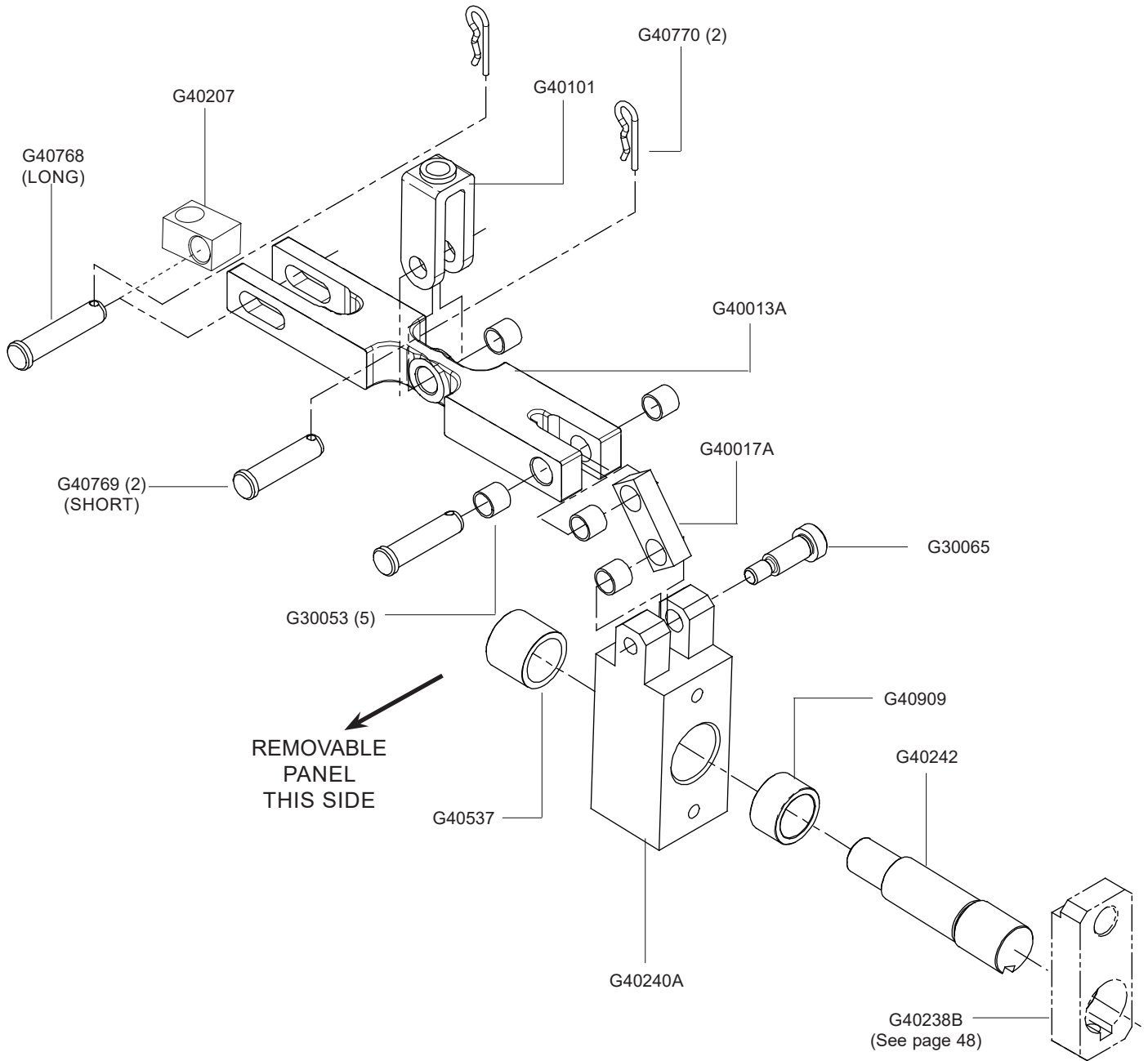

Figure 43 - Control Collar Adjustment



Internal Assemblies - Compression Adjustment Linkage



Internal Assemblies - Upper Driver Components

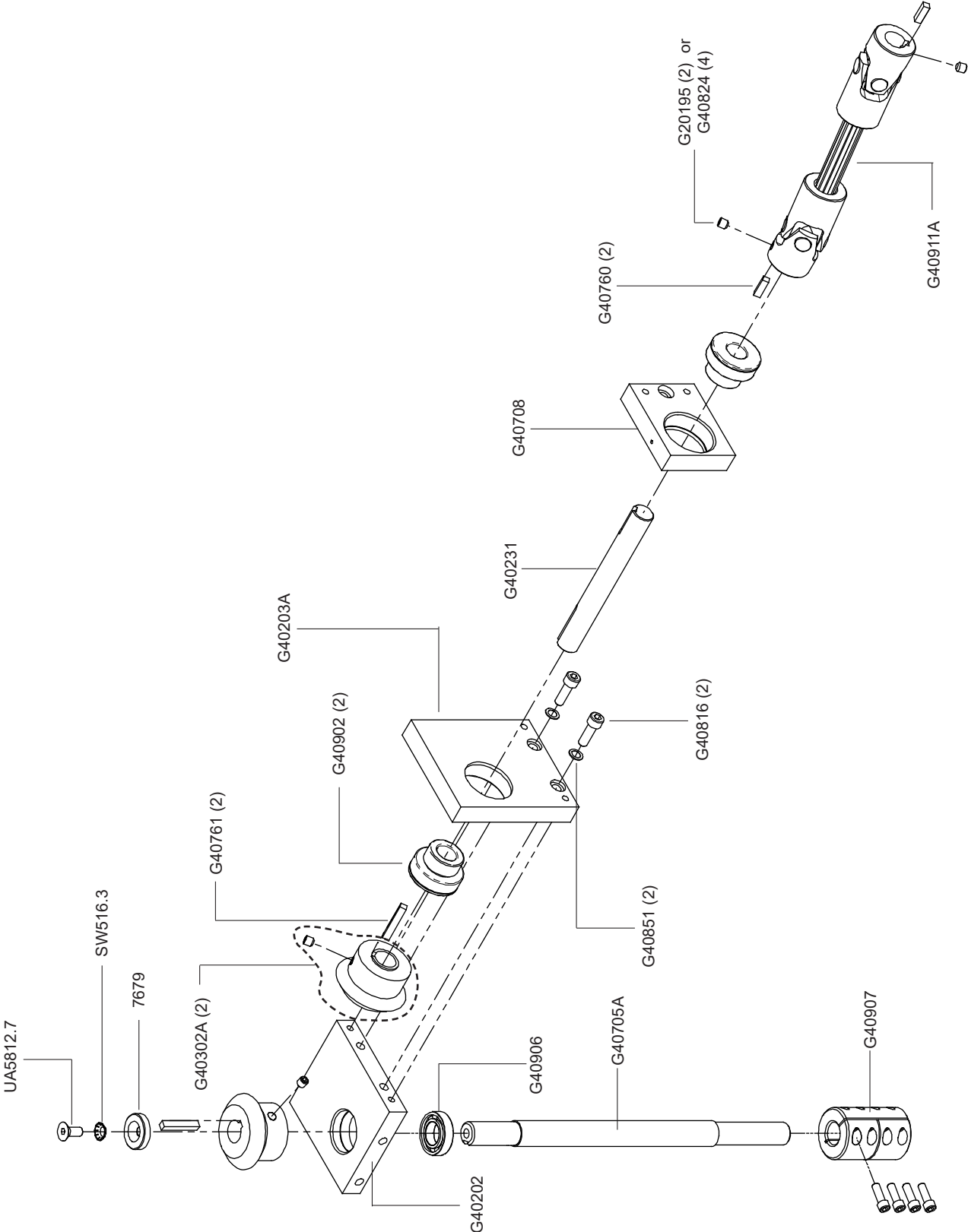

Internal Assemblies - Lower Drive Gear & Bearing Mounts

Lower Drive Gear

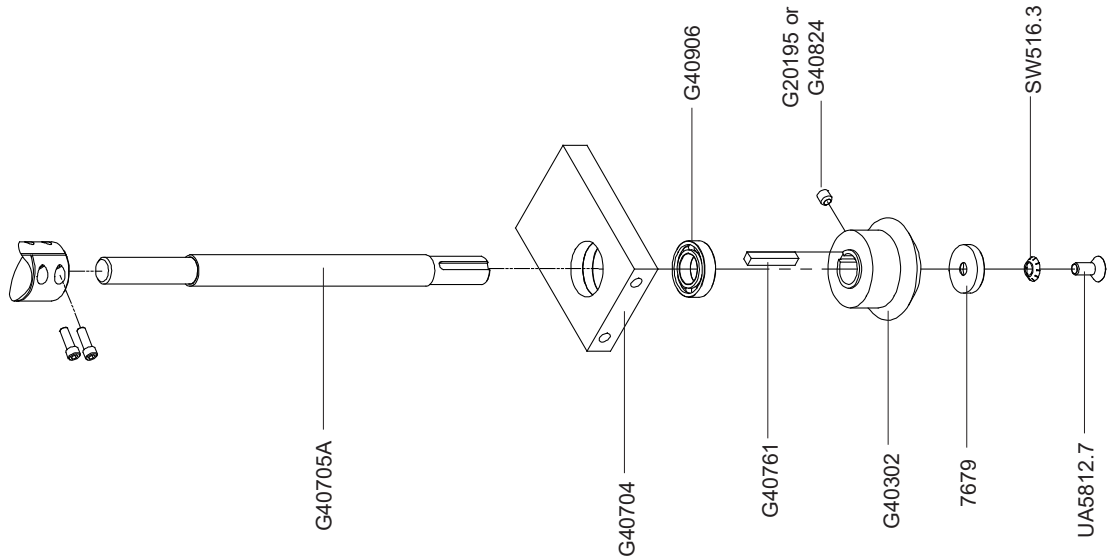

Bearing Mounts

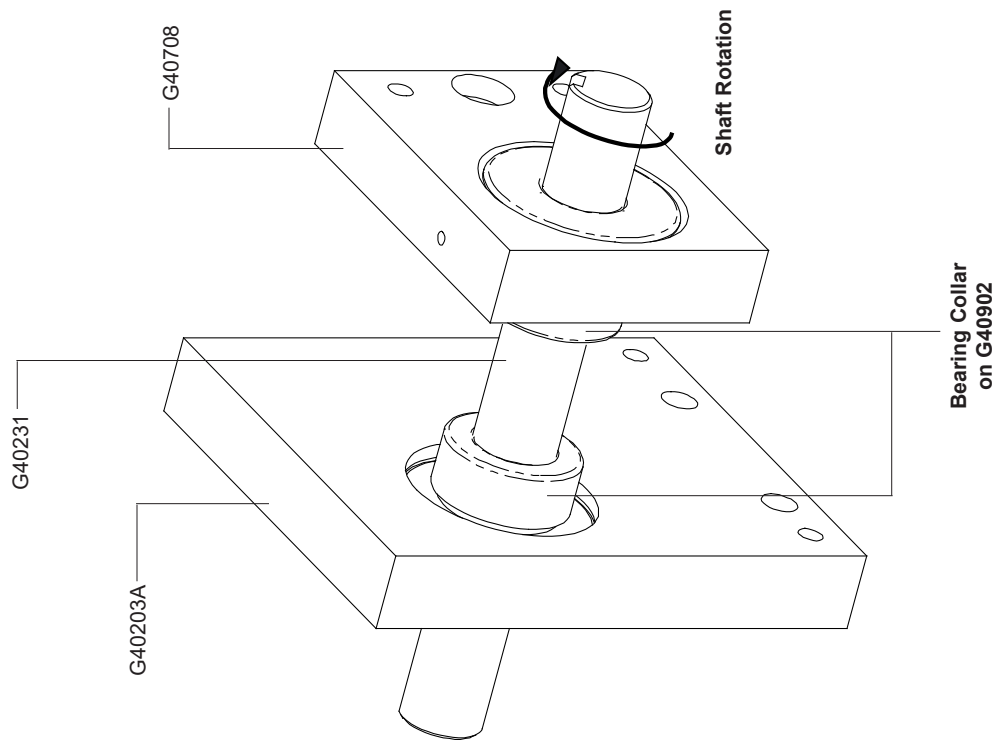

Internal Assemblies - Clincher Cam & Clincher Lever Assemblies

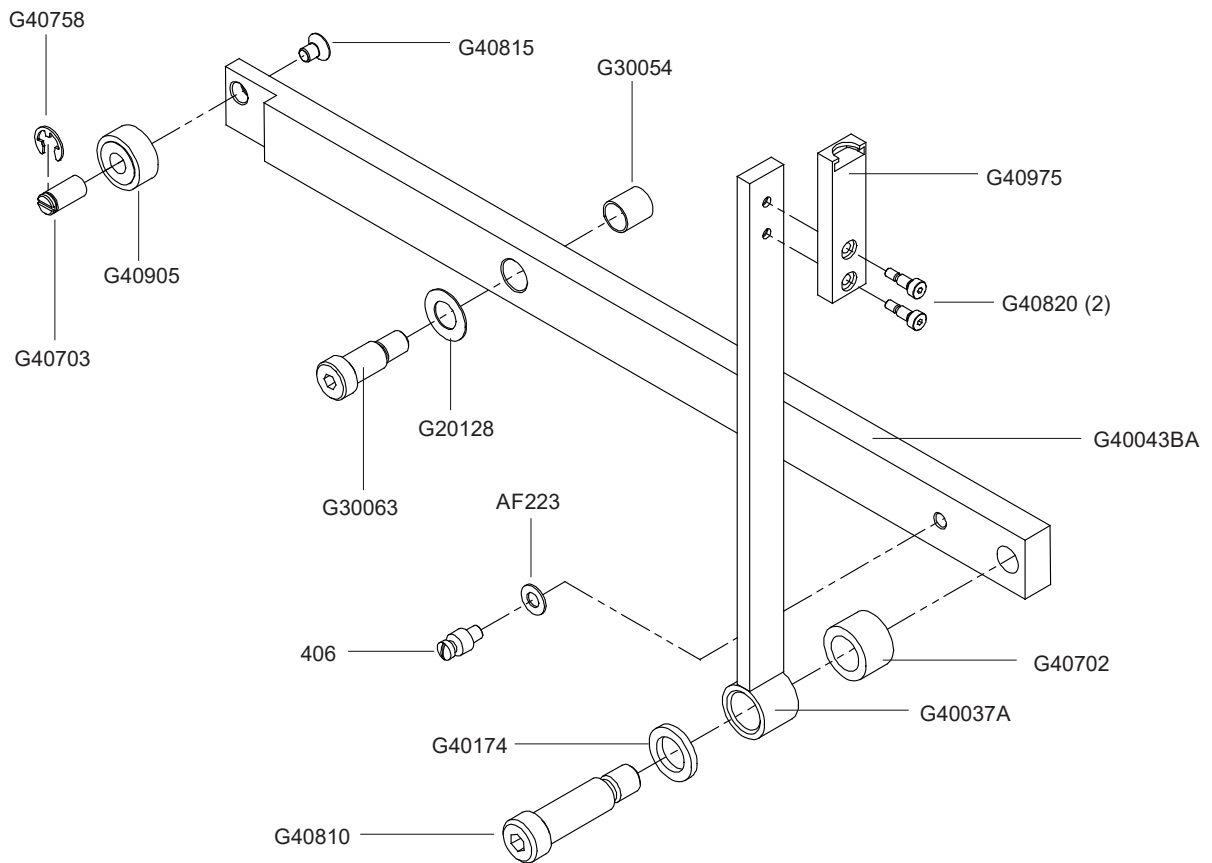
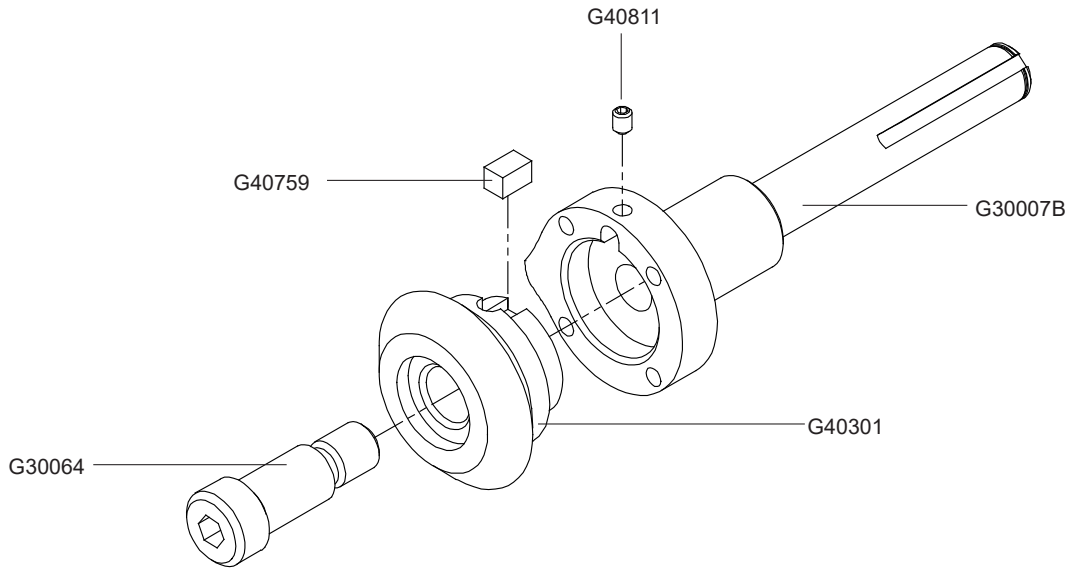

Table and Clincher Assemblies - Clincher Mount & Work Table

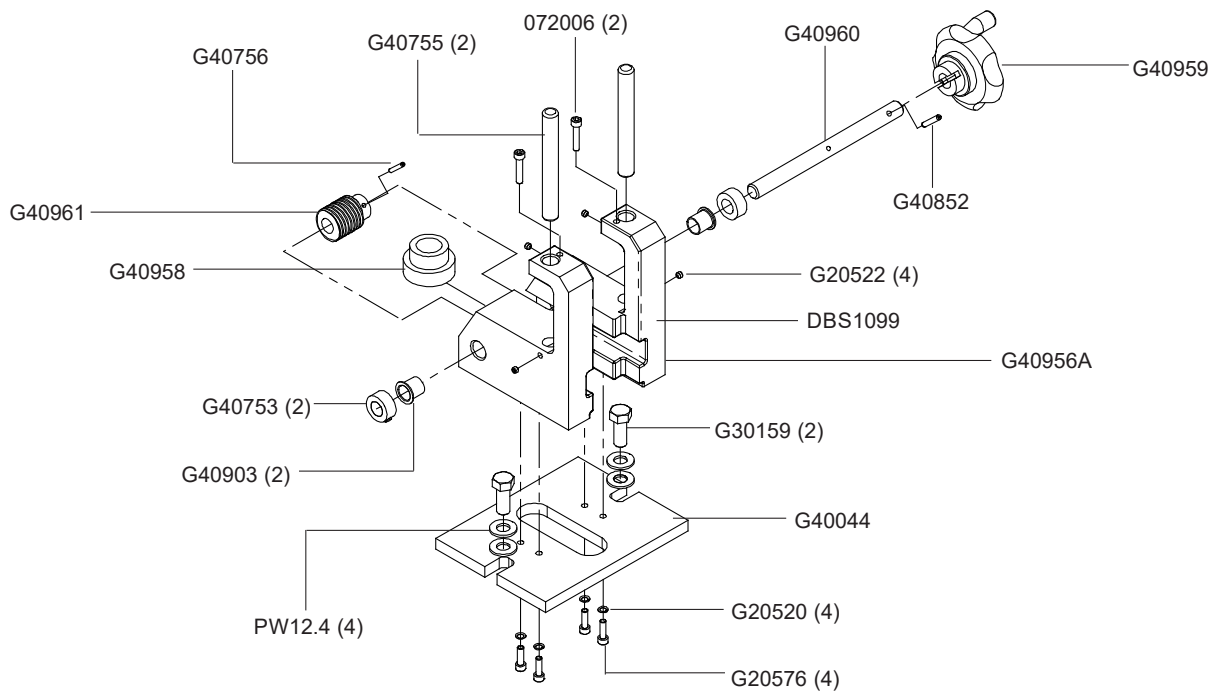
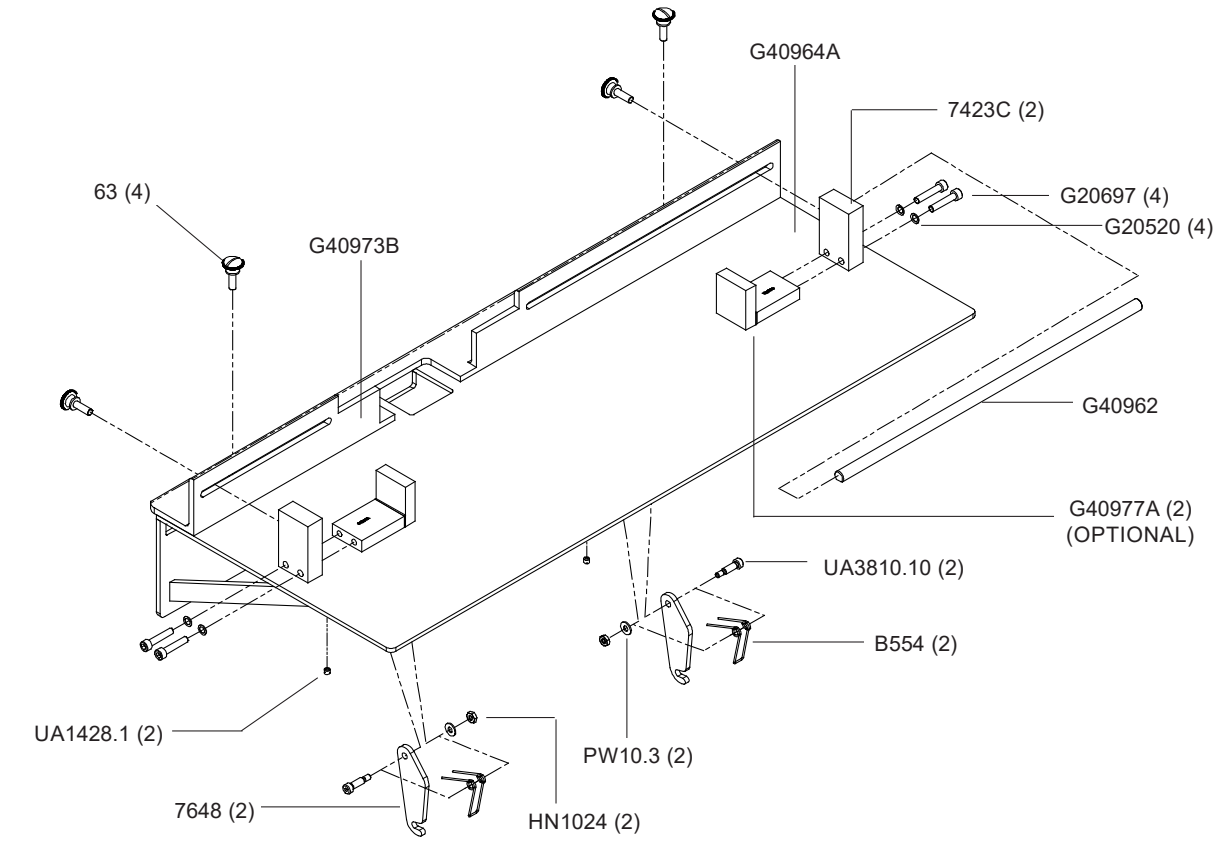
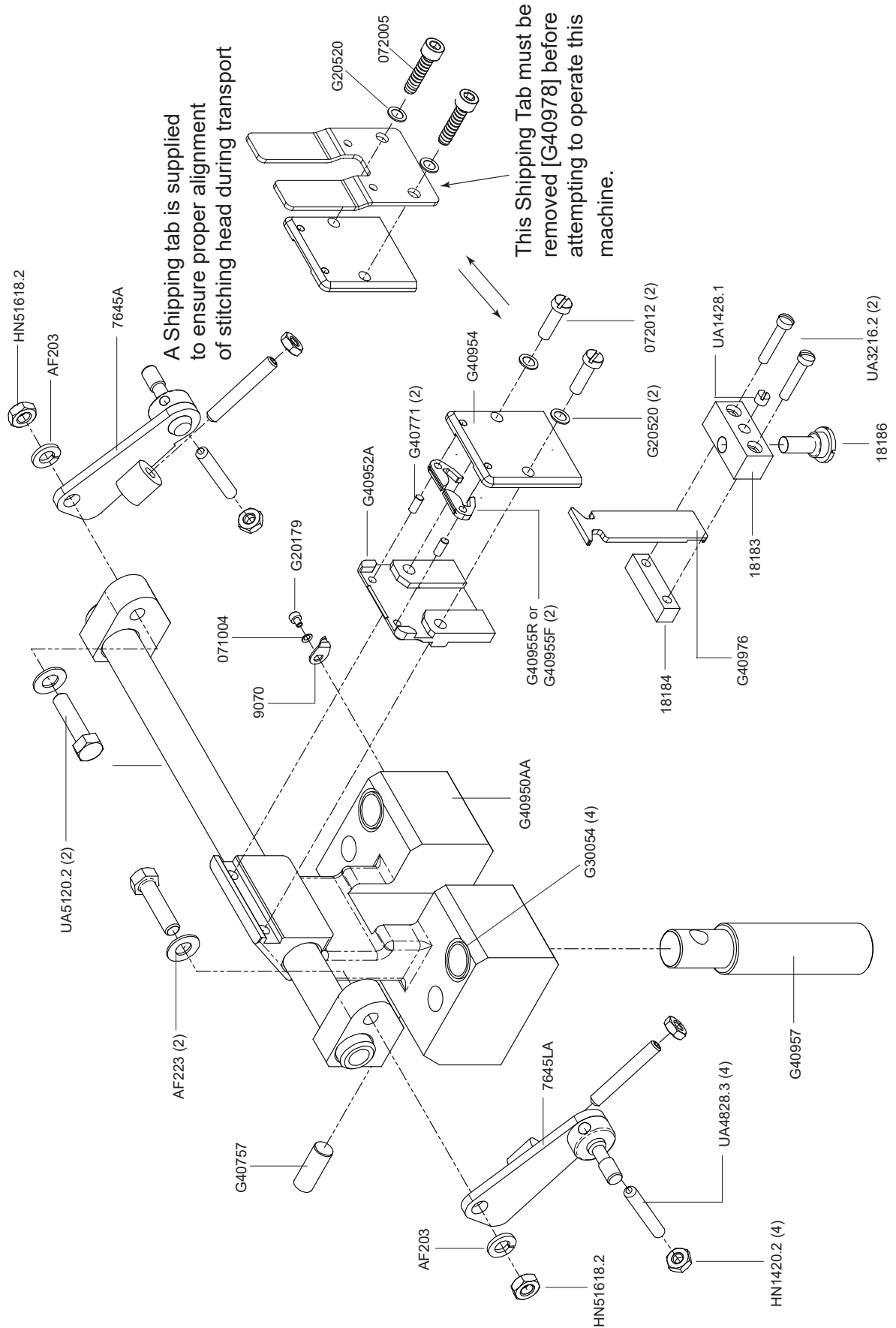
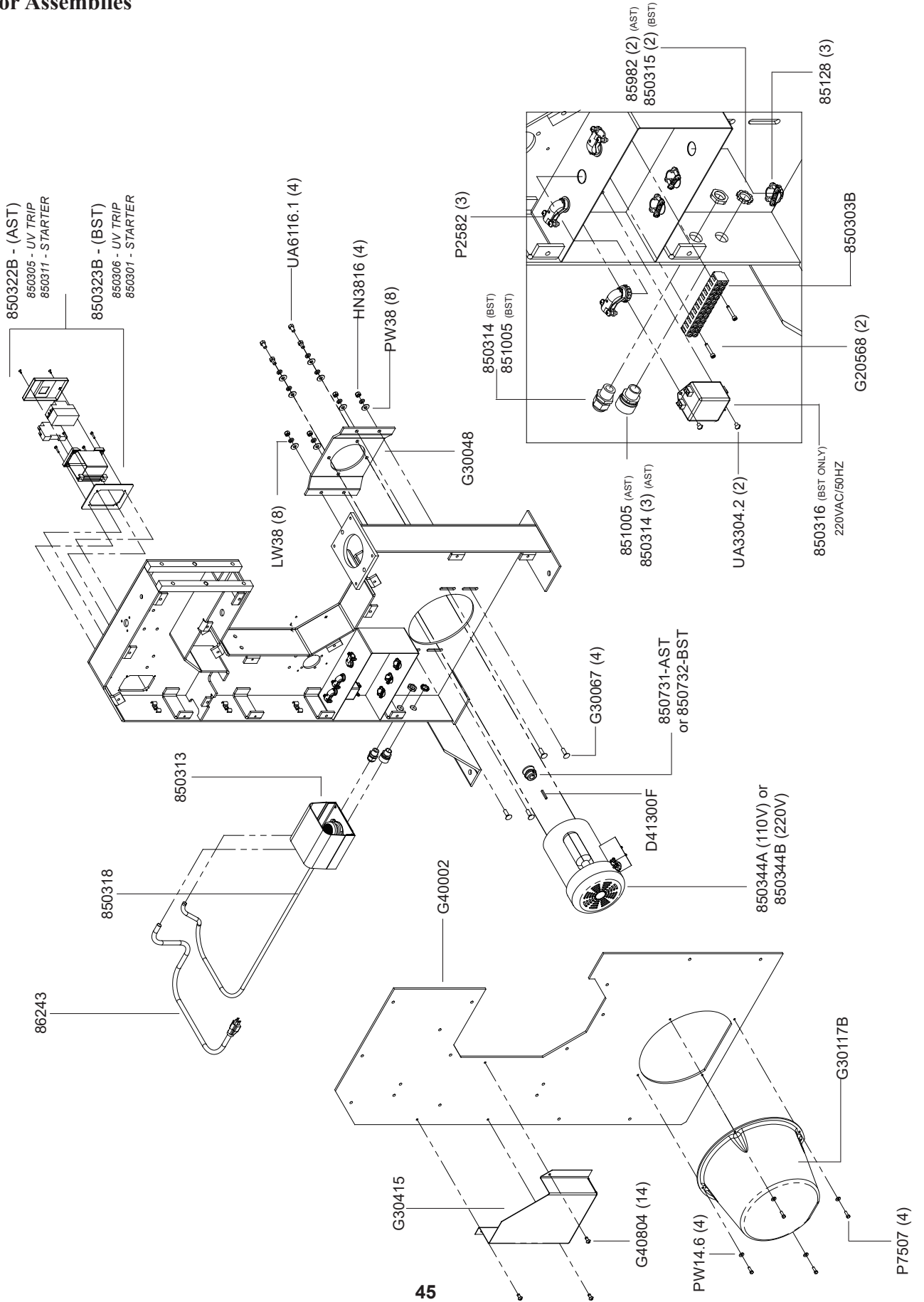

Table and Clincher Assemblies - Clincher Pad



Motor Assemblies



Guard Assembly

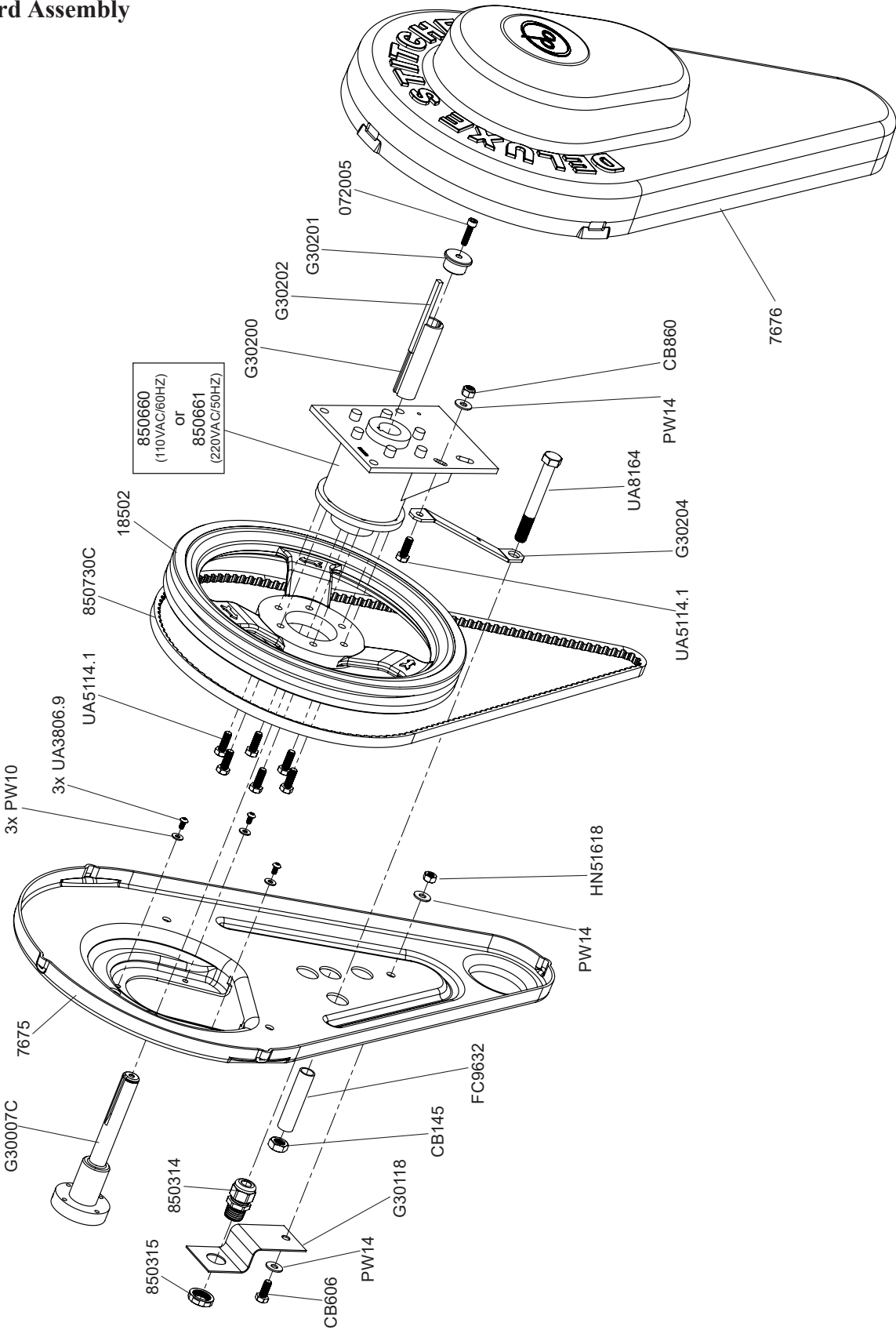

External and Head Assemblies - Head Crank & Driving and Bending Cam

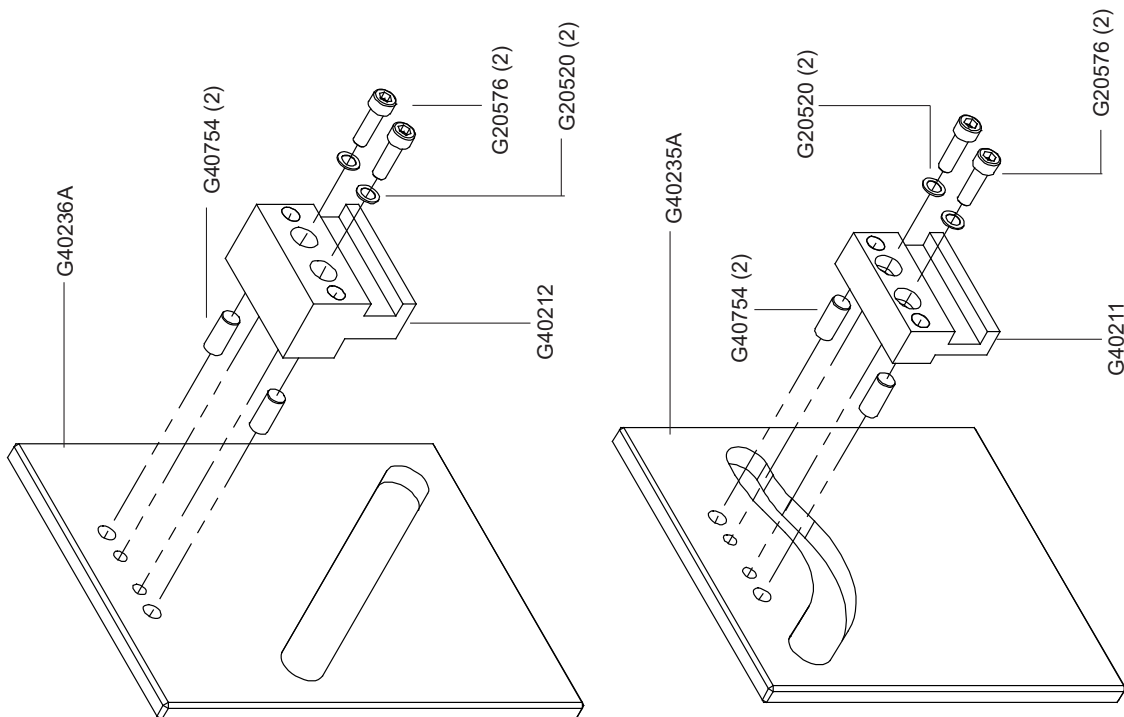
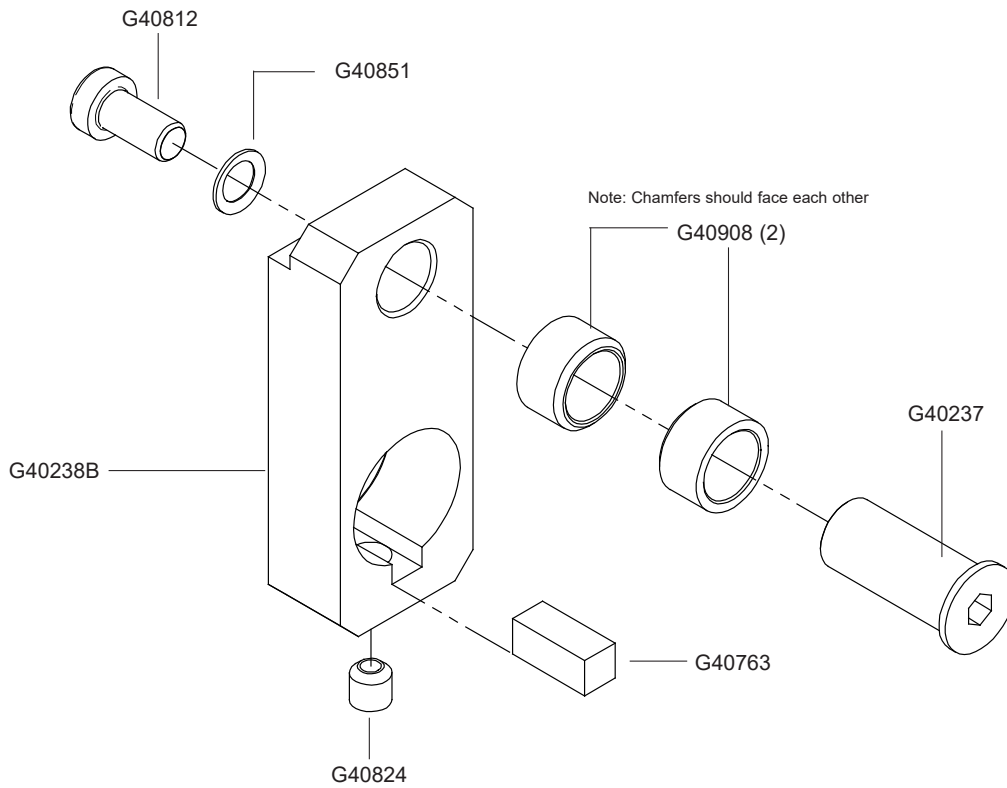

External and Head Assemblies - Hand Wheel Assembly

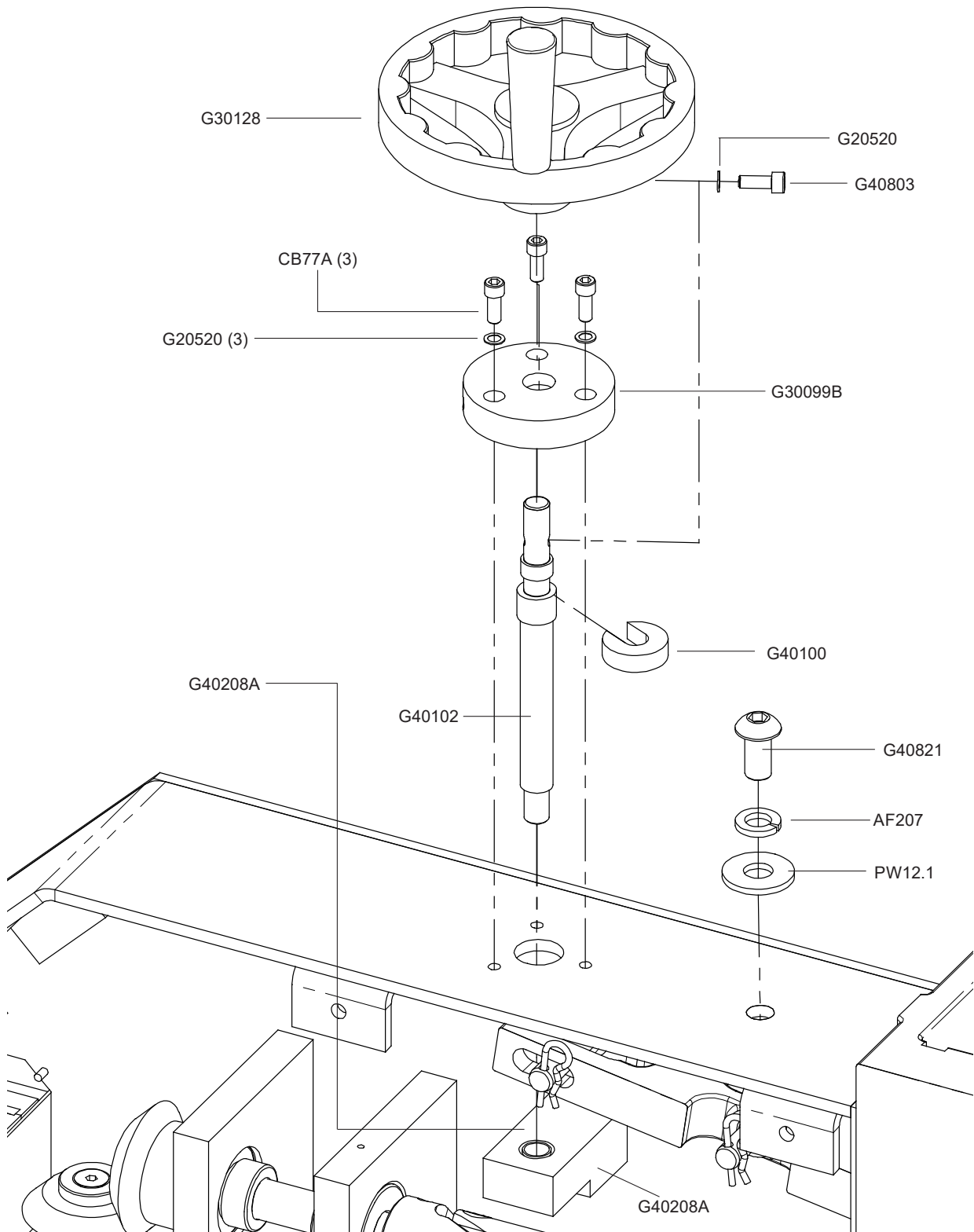

External and Head Assemblies - Bonnet Plates

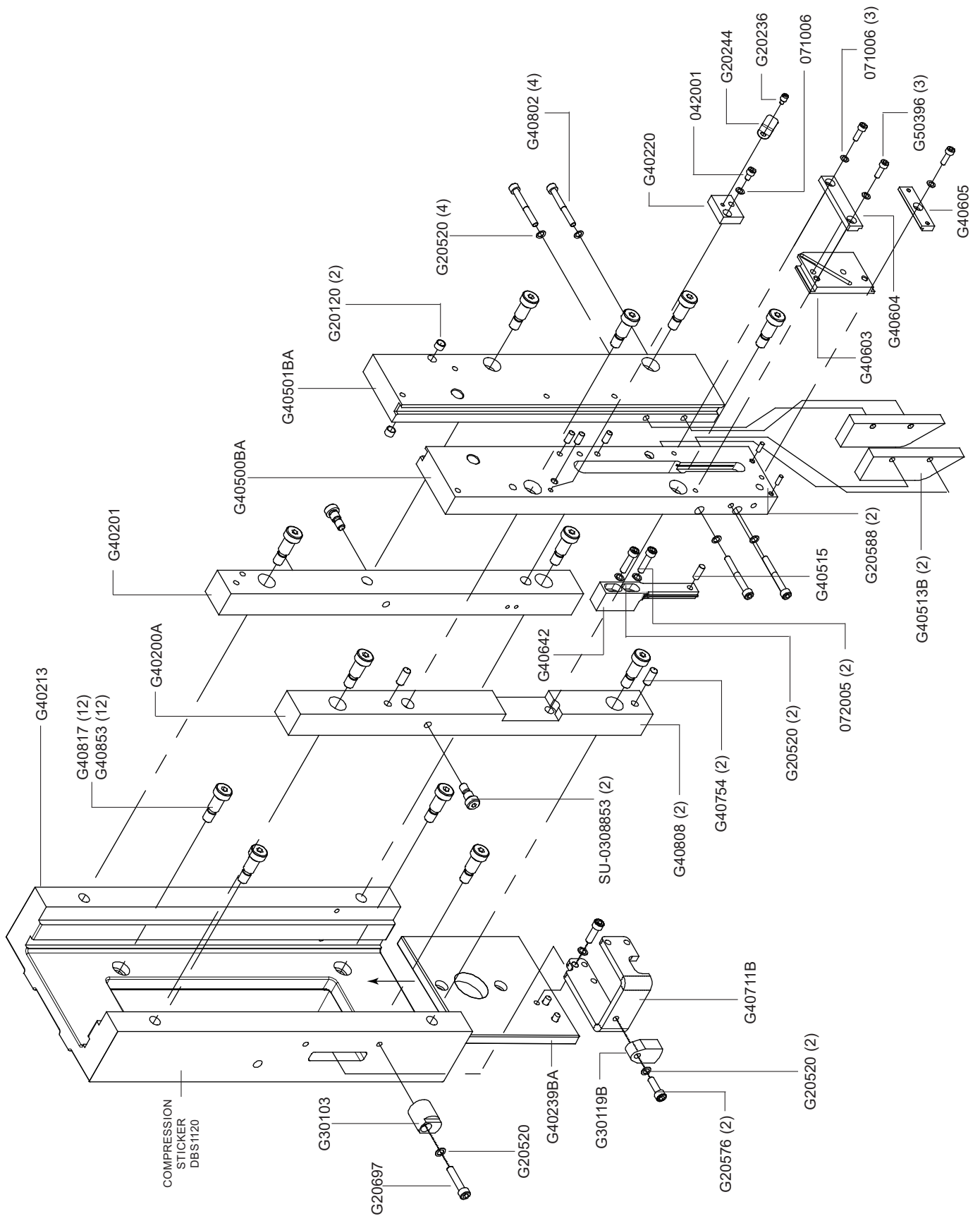

External and Head Assemblies - Feed Slide and Bender Bar

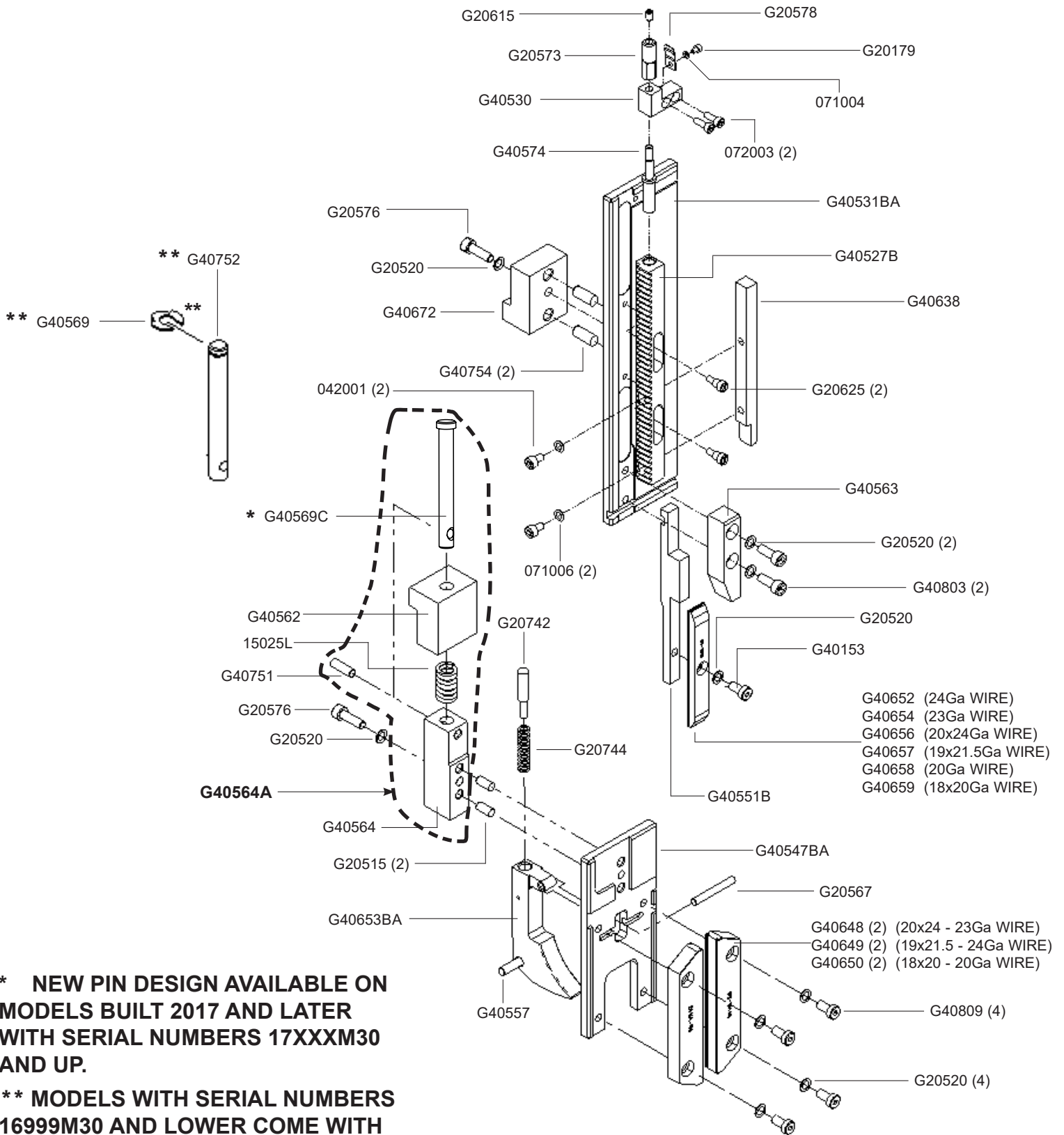

*** NEW PIN DESIGN AVAILABLE ON MODELS BUILT 2017 AND LATER WITH SERIAL NUMBERS 17XXM30 AND UP.**

**** MODELS WITH SERIAL NUMBERS 16999M30 AND LOWER COME WITH PIN AND SNAP RING.**

NEW PIN CAN BE INSTALLED IN OLDER MACHINES.

External and Head Assemblies - Feed Lever & Feed Gear Bracket

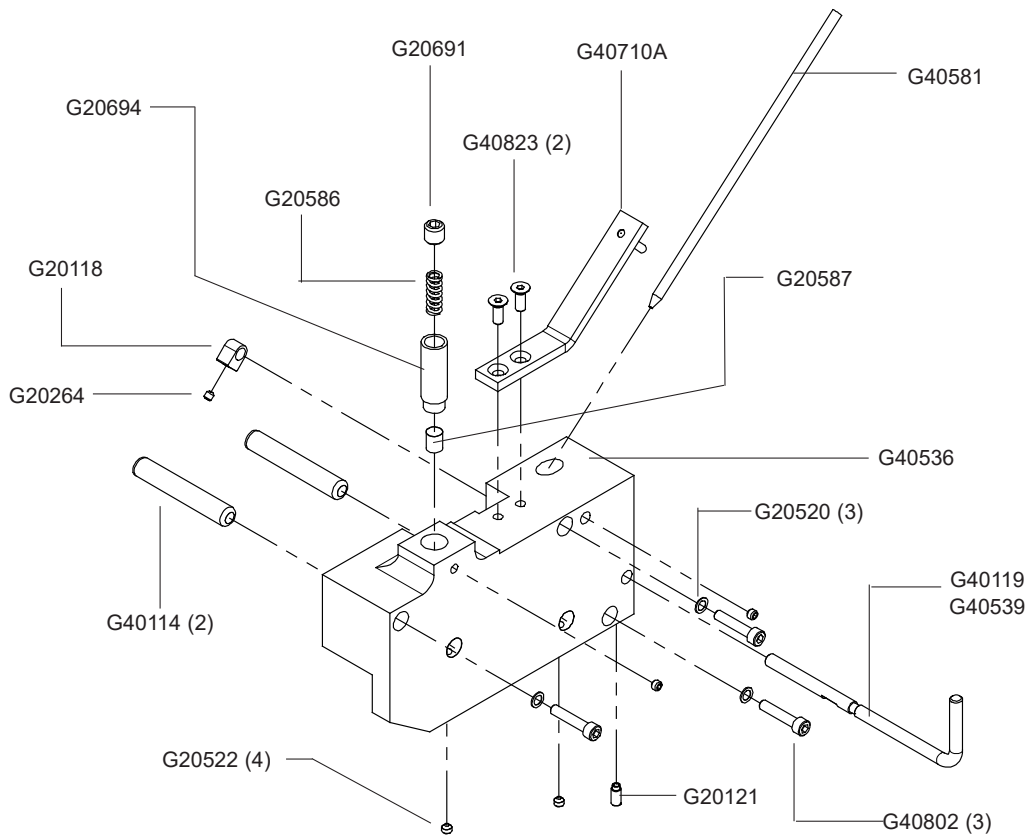
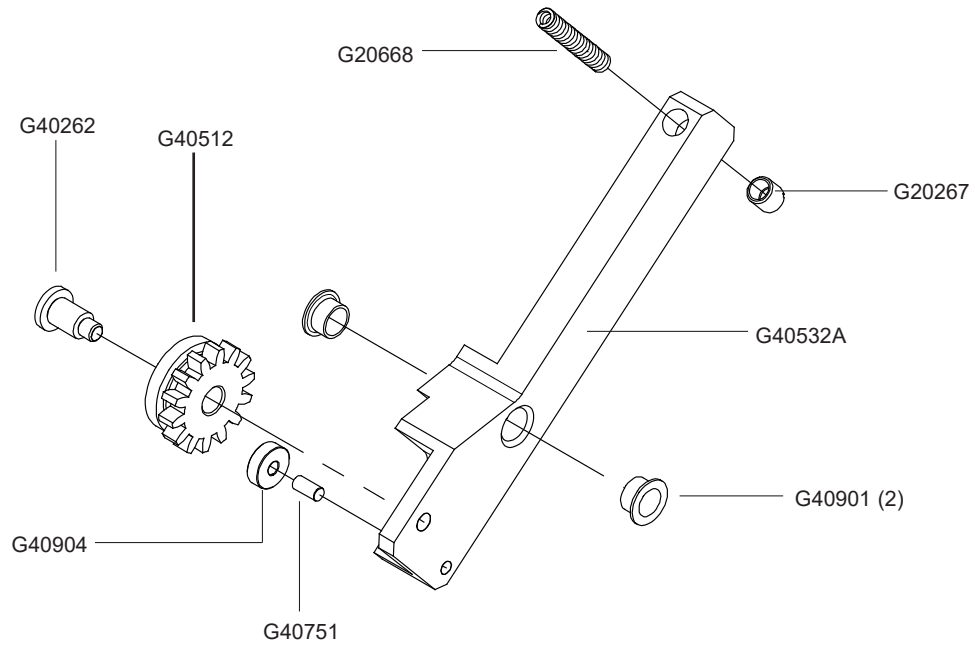

External and Head Assemblies - Cutter Box & Cutter Operating Lever

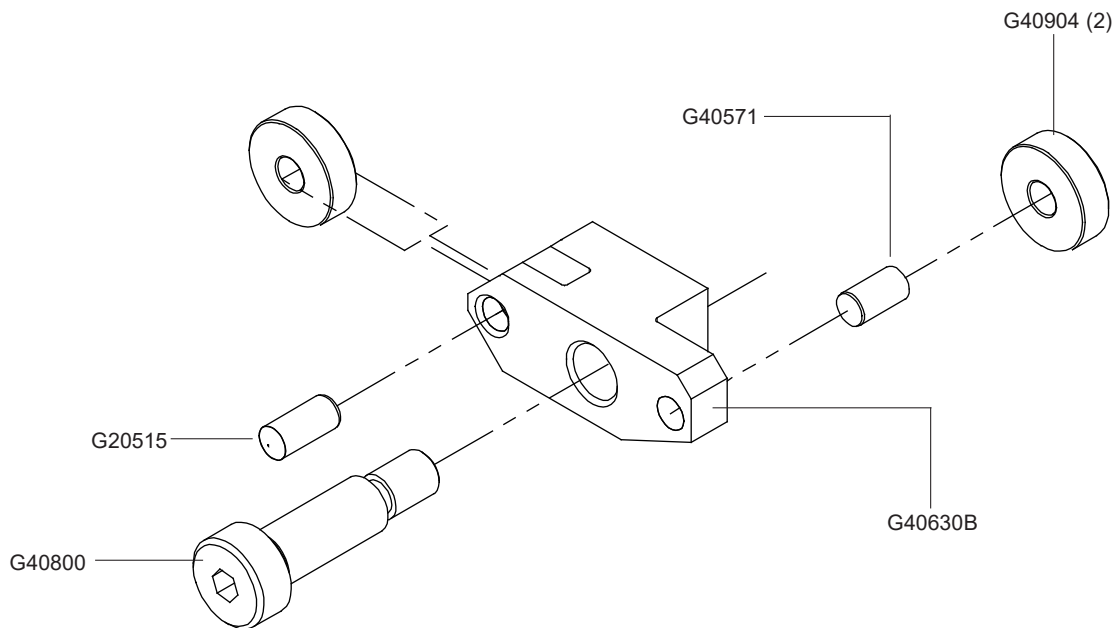
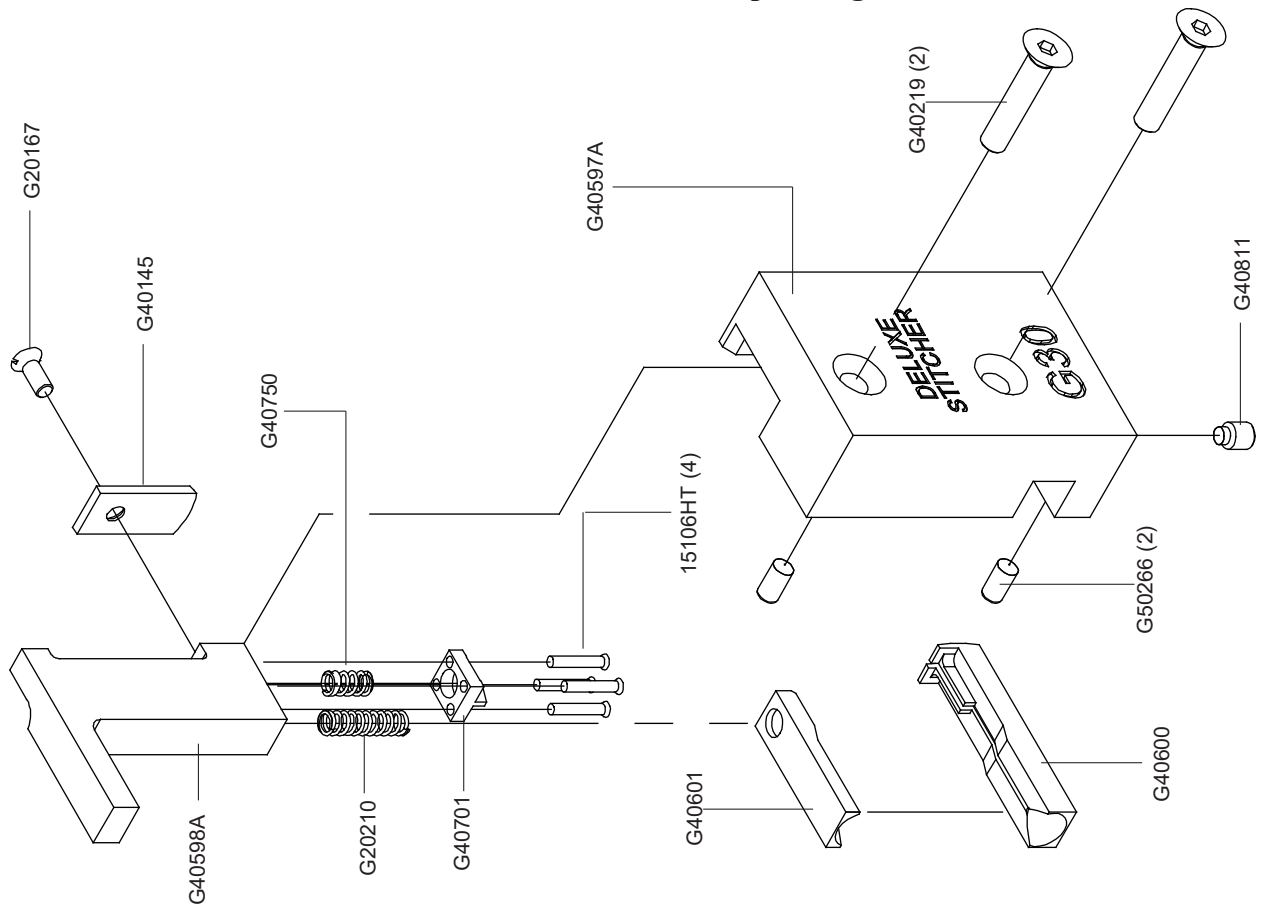

External and Head Assemblies - Pivot Block & Wire Holder

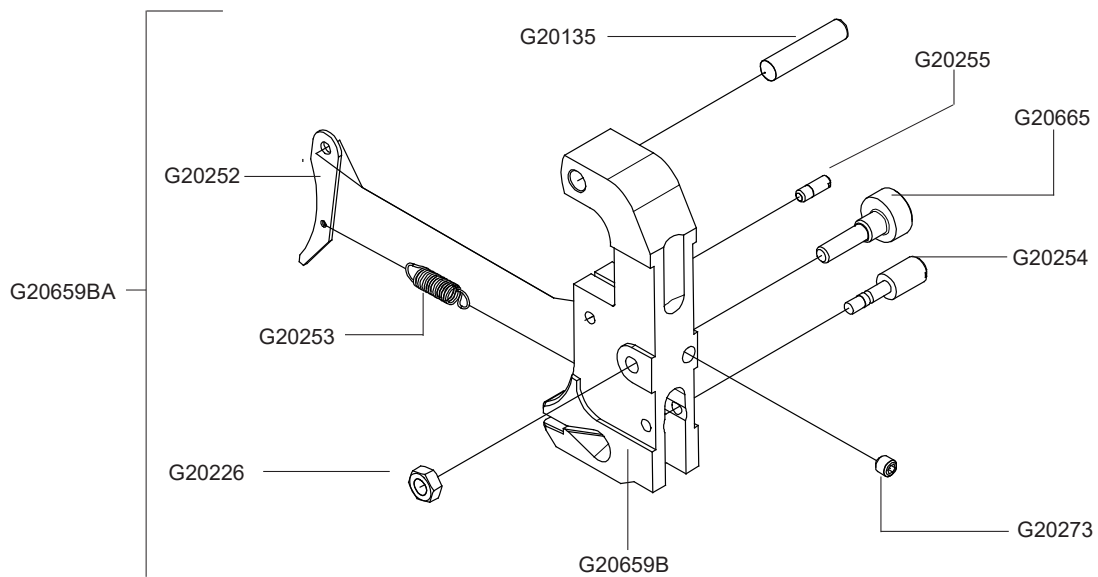
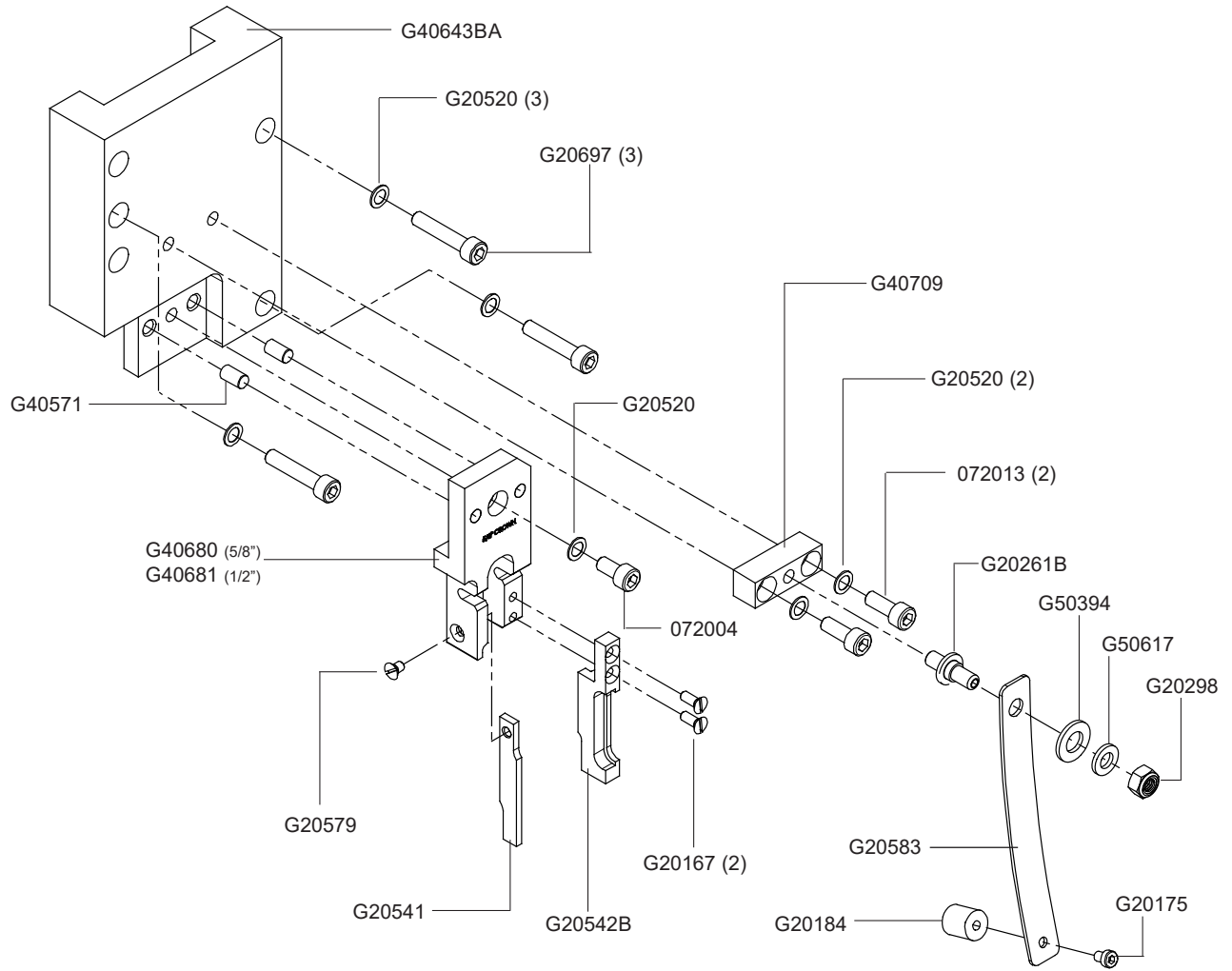

External and Head Assemblies - Large Feed Gear & Lower Wire Straightener

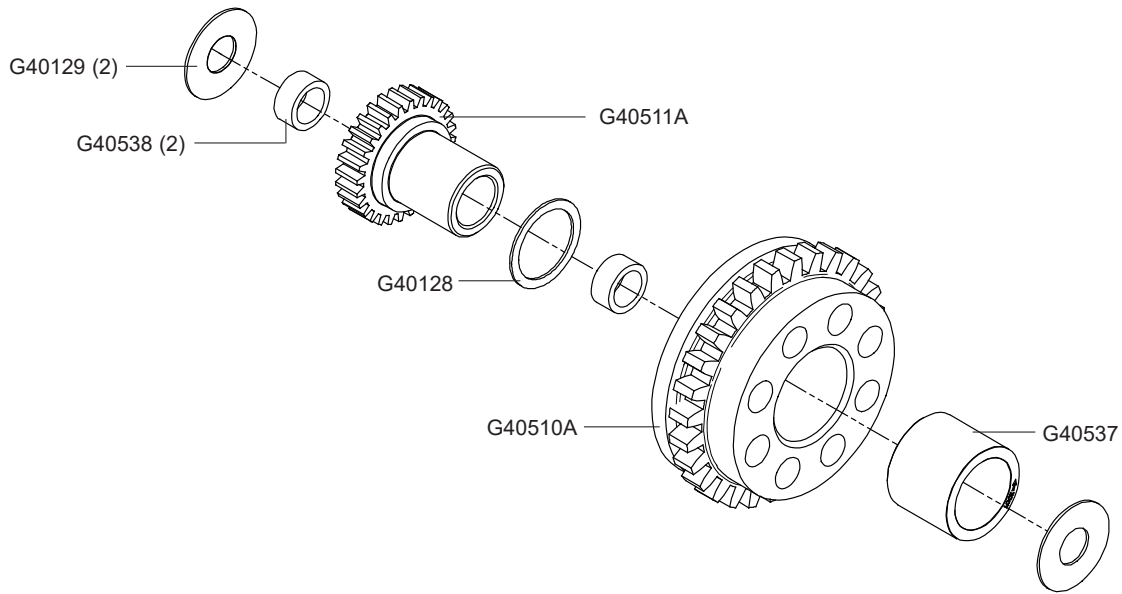

**FOR M30 MACHINES WITH SN STARTING FROM XXXXXX
LOOK AT NEW WIRE STRAIGHTENER WITH NEW WIREGUIDE SPRING
SEE PAGE 55 AND PAGE 57**

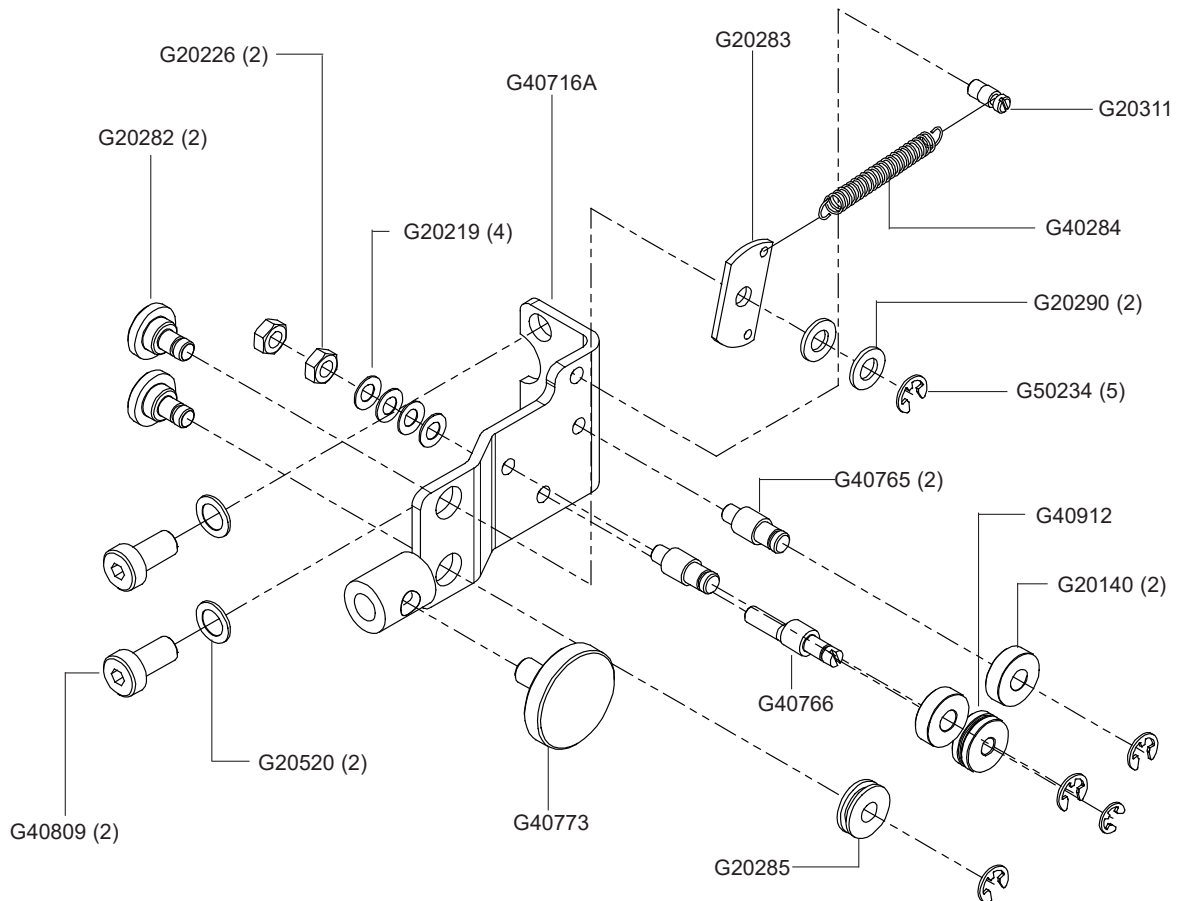

External and Head Assemblies - NEW Lower Wire Straightener

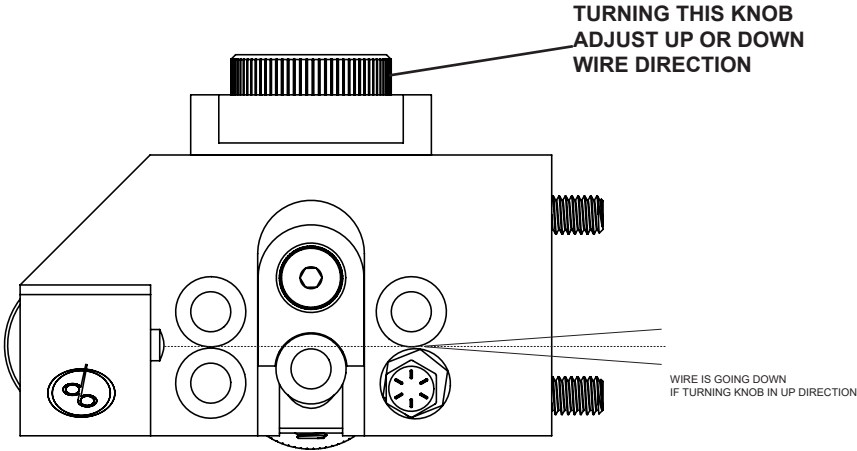
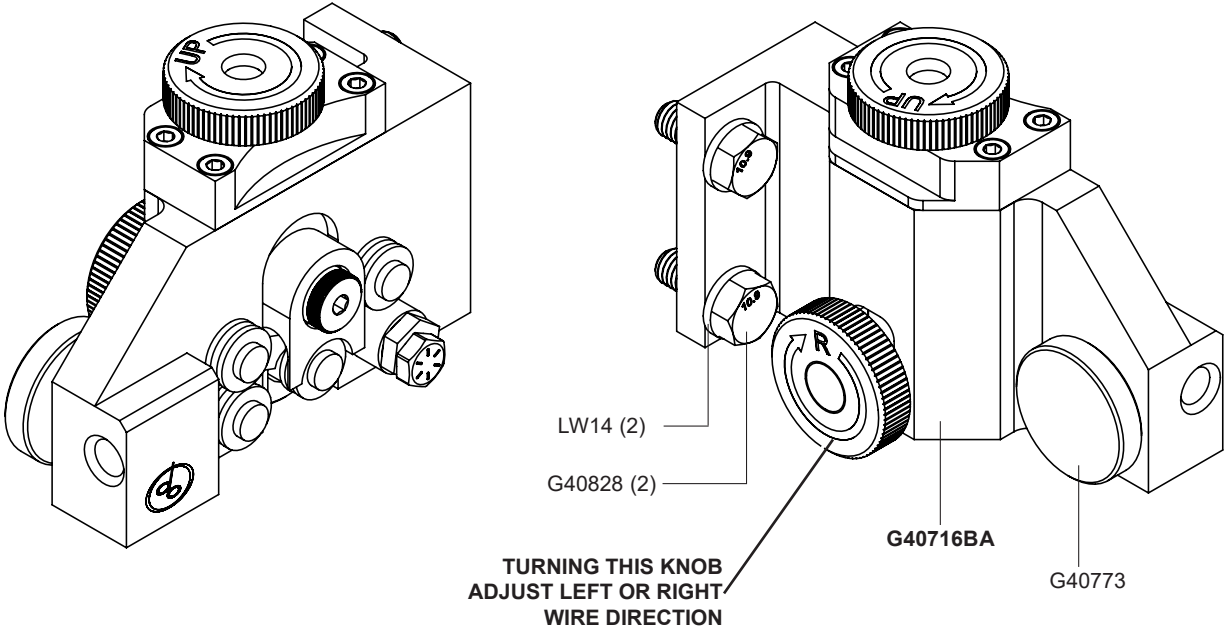

External and Head Assemblies - Wire Guide Spring

**FOR M30 MACHINES WITH SN STARTING FROM XXXXXX
LOOK AT NEW WIRE STRAIGHTENER WITH
NEW WIREGUIDE SPRING
SEE PAGE 55 AND PAGE 57**

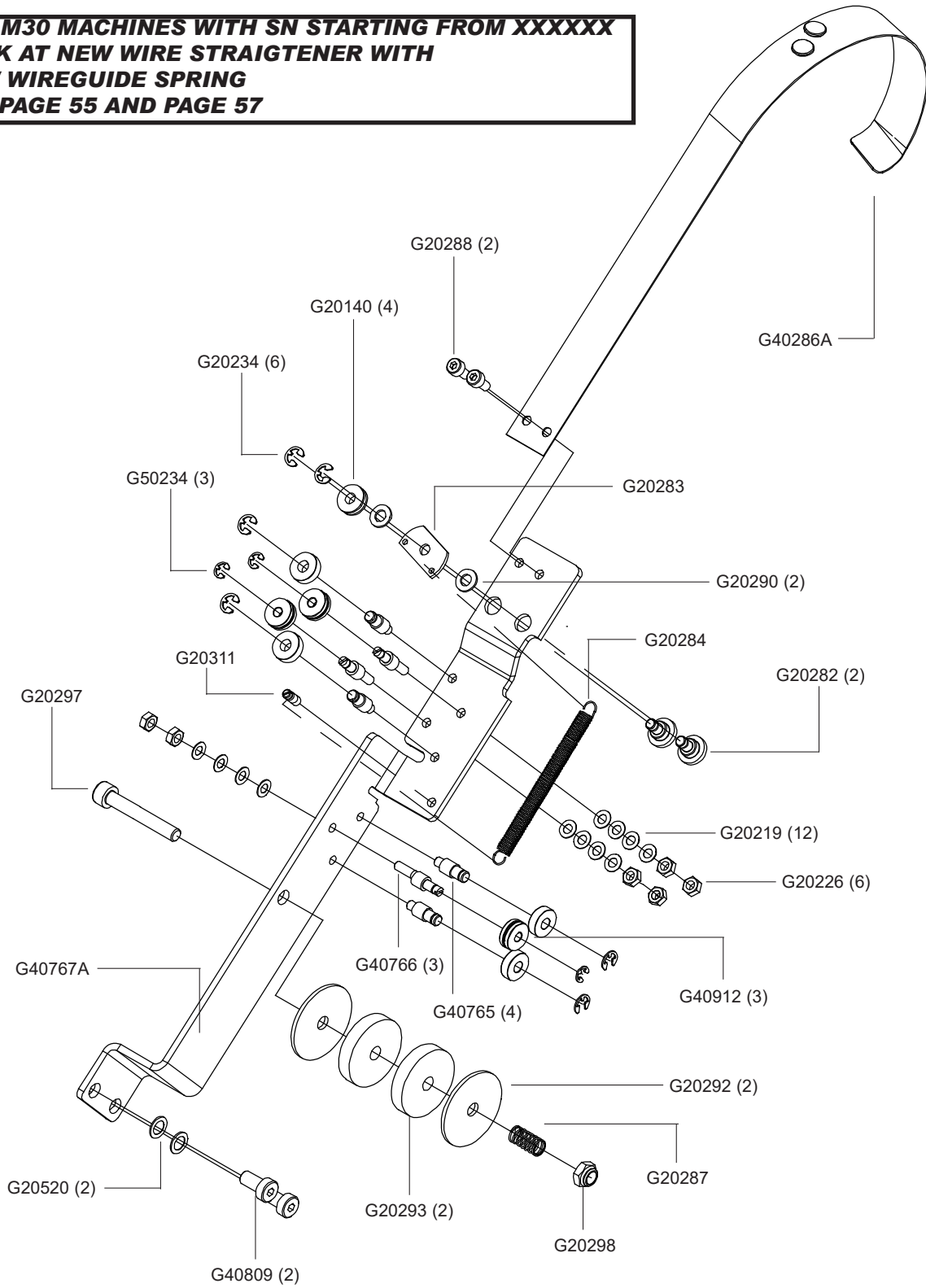

External and Head Assemblies - NEW Wire Guide Spring

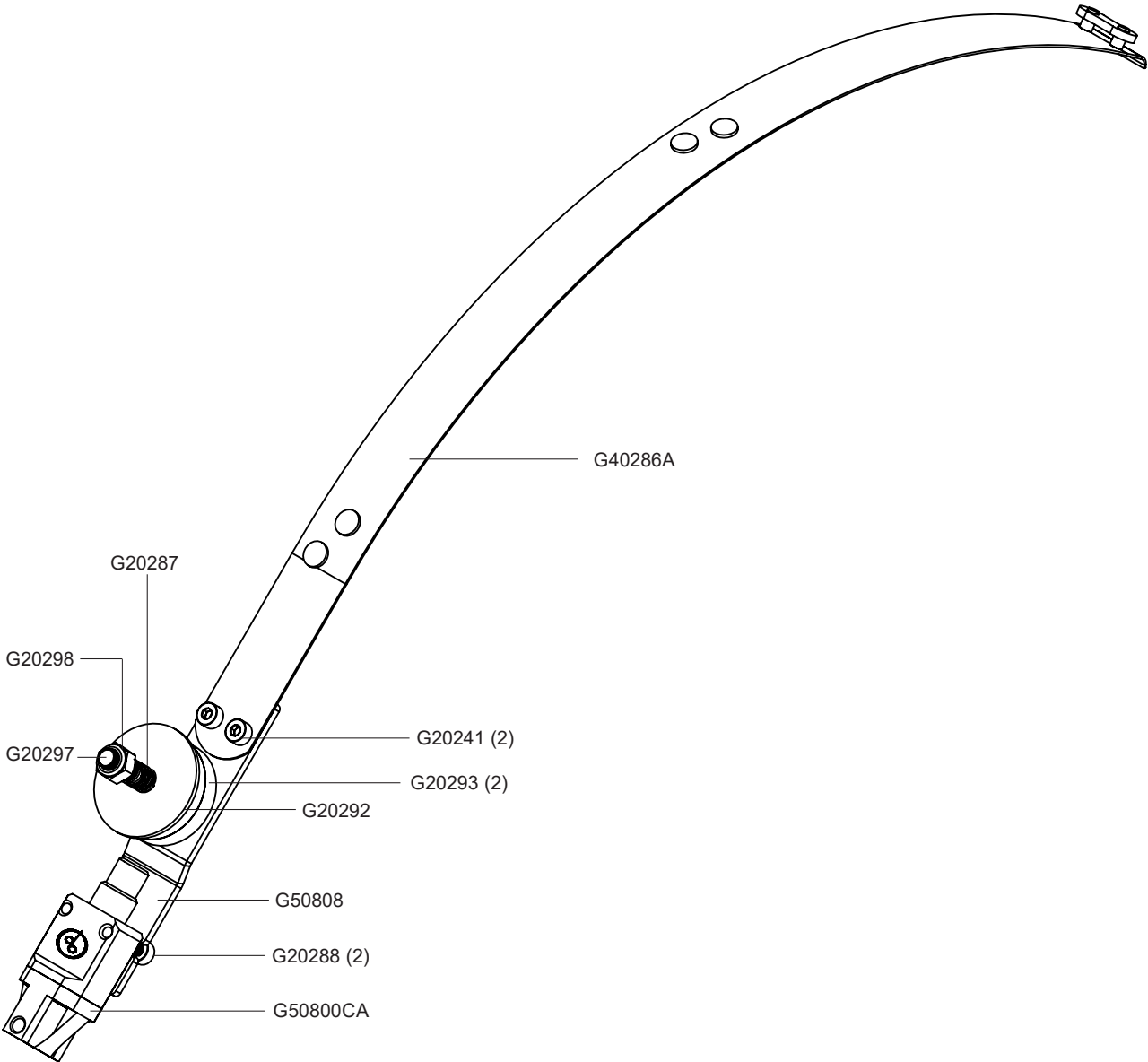

External and Head Assemblies - Head Guard

**FOR M30 MACHINES WITH SN STARTING FROM XXXXXX
LOOK AT NEW WIRE STRAIGHTENER WITH
NEW WIREGUIDE SPRING
SEE PAGE 55 AND PAGE 57**

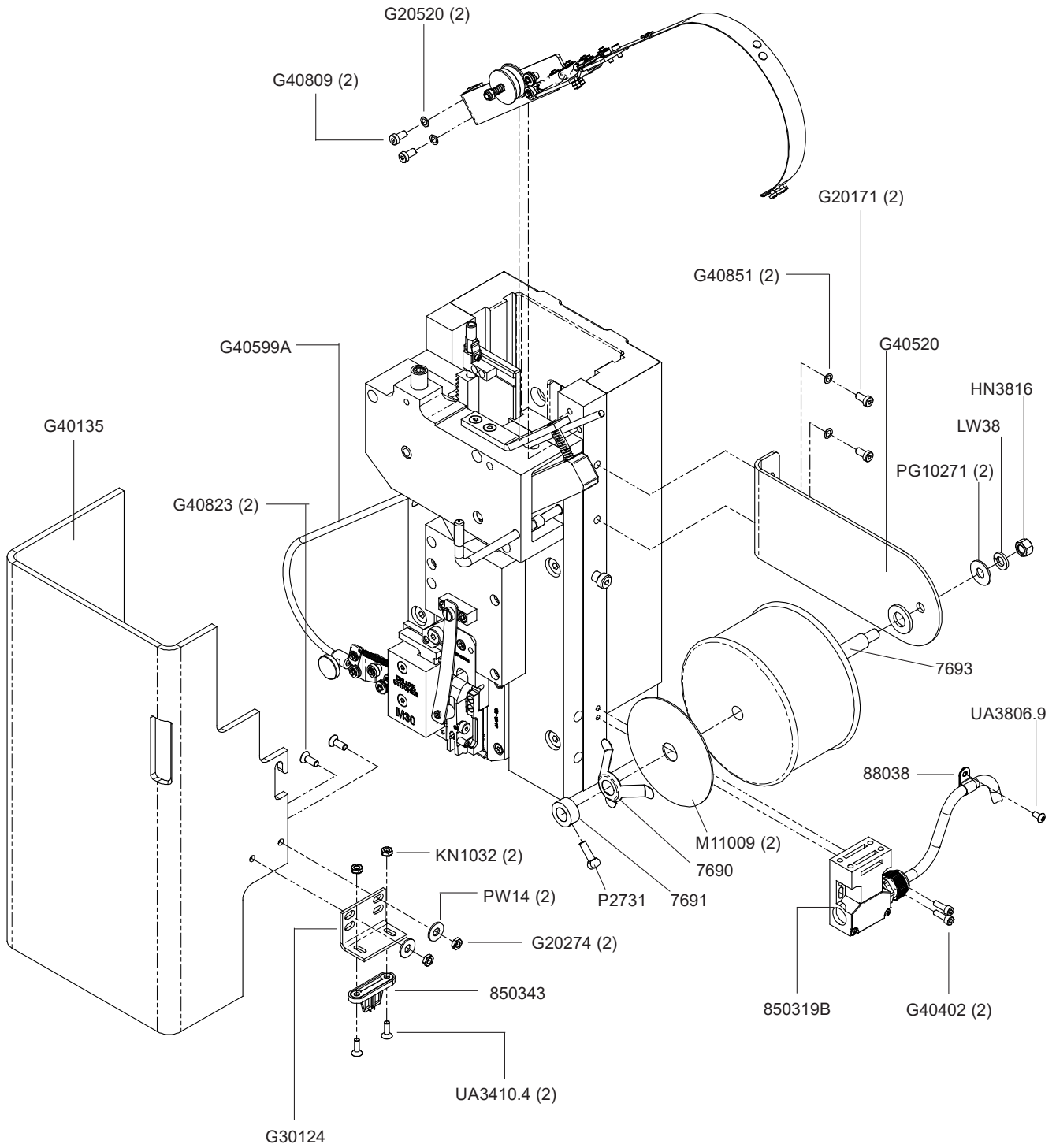

Part Number / Description Cross-Reference

PART NO.	DESCRIPTION	QUANTITY	PART NO.	DESCRIPTION	QUANTITY
042001	Screw M5x.8x8	3	850730C	V-Belt	1
071004	Lock Washer Ribbed M3	2	850731	Pulley	1
071005	Lock Washer Ribbed M4	2	850732	Pulley	1
071006	Lock Washer Ribbed M5	6	851005	Strain Relief	2
072003	Screw M4x0.7x12	2	85128	Connector 3/8	3
072004	Screw M6x1.0x12	1	85982	Lock Nut 1/2	1-2
072005	Screw M6X1.0X25	1	86243	Power Cord - 115V	1
072006	Screw M6x1.0x30	2	88038	Nylon Cable Clamp	1
072012	Screw M6x1.0x20	2	9070	Wire Straightener Eccentric Pointer	1
072013	Screw M6x1.0x22	2	AF203	Lock Washer 5/16 Hel	2
15025L	Bender Slide Spring - Light Duty	1	AF207	Lock Washer 1/2 Helical Spring	1
18183	Clincher Slide Adjustment Block	1	AF223	Flat Washer 5/16	4
18184	Clincher Slide Block Clamp	1	B554	Torsion Spring	2
18186	Clincher Slide Adjustment Screw	1	FC9633	Shaft Key	1
18502	Drive Pulley, CB-7 Clutch	1	FC9656A	Clutch Anchor Assembly	1
19211/2G5	Wire Spool - Galvanized	1	G20118	Feed Release Handle Cam	1
35	Clincher Slide Link Spring	1	G20121	Feed Release Plunger	1
36	Pin	1	G20135	Dowel Pin M5x24	1
406	Clincher Oper. Lever Spring Screw	1	G20140	Follower Ball Bearing	4
63	Work Guide Screw	4	G20153	Driver Retaining Screw	1
7423C	Work Stop - Large	2	G20167	Screw M4x.7x10	3
7645A	Table Support Bracket Asy - RH	1	G20171	Screw M8x1.25x12	2
7645LA	Table Support Bracket Asy - LH	1	G20175	Screw M4x.7x6, with Nylon Patch	1
7648	Table Support	2	G20179	Screw M3x.5x4	2
7675	Belt Guard Base	1	G20184	Wire Holder Retaining Spring Foot	1
7676	Belt Guard Cover	1	G20190	Screw M3x.5x10	2
7678B	Drive Pulley - 4L	1	G20195	Screw M6x1.0x8	3
7679	Drive Pulley Washer	2	G20210	Cutter Operating Spring	1
7690	Tension Spring	1	G20219	Wire Straightener Disc Spring	8
7691	Set Collar - Reamed	1	G20226	Hex Nut M4x.7	4
7693	Spool Stud	1	G20234	E-Ring 3/16	4
850303B	Terminal Strip - Holes	1	G20236	Tube Pivot Screw	1
850307	Power Cord - 230V	1	G20244	Tube Pivot Clip	1
850313	Footswitch Guard	1	G20250	Screw M4x.7x14	2
850314	Strain Relief	2-3	G20252	Wire Hook	1
850315	Strain Relief Nut	2-3	G20253	Wire Hook Spring	1
850316	RFI Filter	1	G20254	Wire Hook Spring Screw	1
850317	Clutch, Wire Harness	1	G20264	Screw, M5 x 0.8 x 5, Nylon	1
850318	Footswitch, Wired	1	G20267	Feed Lever Bushing	1
850319B	Safety Switch, Wired-Side Mount	1	G20273	Screw M4x.7x4, with Nylon Patch	1
850322B	Starter Assembly 3/4 - 115V	1	G20274	Hex Jam Nut, M6x1	2
850323B	Starter Assembly 3/4 - 230V	1	G20282	Tension Pawl Pivot Pin	2
850337	Wire Terminal Ring	1	G20283	Tension Pawl	1
850344A	Motor 3/4 HP - 115V	1	G20284	Tension Pawl Spring	1
850344B	Motor 3/4 HP - 230V	1	G20285	Tension Pawl Roller	1
850660	CB-7 Clutch - 115V	1	G20286A	Wire Guide Spring Assembly - Long	1
850661	CB-7 Clutch - 230V	1	G20287	Wire Oiler Felt Spring	1
850677	Electric Clutch, Heavy Duty - 115V	1	G20288	Screw M4x0.7x8	2
850678	Electric Clutch - 230V	1	G20290	Flat Washer, M5	2
			G20292	Wire Oil Felt Washer	2

Part Number / Description Cross-Reference

PART NO.	DESCRIPTION	QUANTITY	PART NO.	DESCRIPTION	QUANTITY
G20293	Wire Oiler Felt	2	G30118	Belt Guard Bracket	1
G20297	Screw M6x1.0x40	1	G30119B	Paper Thickness Gauge, M30	1
G20298	Nylock Lock Nut, M6x1	1	G30124	Actuator Key Bracket	1
G20311	Spring Anchor Screw	1	G30127	Starter Mounting Flange	1
G20360	Hex Key Wrench 3.0mm	1	G30128	Hand Wheel	1
G20364	Open End Wrench	1	G30159	Screw 1/2-20x1-1/4	2
G20368	Feed Release Handle Cap	1	G30163	Self Tapping Screw	1
G20515	Dowel Pin M6x14	3	G30176	Screw M4x.7x25	2
G20520	Ribbed Lock Washer M6	44	G30183	Self Tapping Screw	2
G20522	Screw M6x1.0x5	8	G30200	Adapter, CB-7 Clutch	1
G20530	Feed Rack Block	1	G30201	End Cap, CB-7 Clutch	1
G20541	Wire Guide Bar - Left	1	G30202	Key-Rectangular, CB-7 Clutch	1
G20542B	Wire Guide Bar - Right	1	G30203	Crank Shaft, CB-7 Clutch	1
G20566	Screw M4x0.7x20	4	G30204	Clutch Anchor, CB-7 Clutch	1
G20567	Dowel Pin M5x40	2	G30415	Tool Kit Hanger	1
G20570	Spirol Pin M5x20	1	G40001A	Frame Weldment, M30	1
G20573	Feed Rack Adjustment Knob	1	G40002	Side Cover Plate-Left, M30	1
G20574	Feed Rack Adjustment Stud	1	G40013A	Pivot Arm Assembly	1
G20576	Screw M6x1.0x20	11	G40017A	Crank Housing Connecting Link Assy	1
G20578	Rack Adjustment Knob Detent	1	G40037A	Clincher Upright Link Assembly	1
G20579	Screw M4x0.7x6	1	G40043A	Clincher Lever Assembly	1
G20583	Wire Holder Retaining Spring	1	G40044	Clincher Mounting Plate	1
G20586	Feed Gear Friction Spring	1	G40100	Adjuster Crank Shaft Insert	1
G20587	Feed Gear Friction Plug	1	G40101	Compression Adjustment Yoke	1
G20588	Dowel Pin M4x12	2	G40102	Adjustment Shaft	1
G20589	Screw M4x0.7x10	1	G40114	Feed Gear Shaft	2
G20615	Screw M5x0.8x8	1	G40119	Feed Release Handle	1
G20617	Washer M6x18x1.6	1	G40128	Rear Feed Gear Spacer	1
G20625	Feed Rack Guide Screw, Nylon	2	G40129	Large Feed Gear Washer	2
G20626	Screw M4x0.7x16	2	G40135	Head Guard	1
G20659BA	Wire Holder Assembly 5/8 Cr.	1	G40145	Moving Wire Cutter	1
G20661	Wire Holder Retaining Spring Screw	1	G40153	Driver Retaining Screw	1
G20665	Wire Holder Eccentric Screw	1	G40174	Small Clincher Arm Spacer	1
G20668	Feed Lever Spring	1	G40200A	Mounting Bar Assembly - Left	1
G20691	Screw M12x1.75x12	1	G40201	Mounting Bar - Right	1
G20694	Feed Gear Friction Bushing	1	G40202	Upper Bearing Block - Horizontal	1
G20697	Screw M6x1.0x30	4	G40203A	Upper Bearing Block Assy - Vertical	1
G20742	Supporter Plunger	1	G40207A	Adjustment Shaft Block Assembly	1
G20744	Supporter Spring	1	G40208A	Adjustment Shaft Support Brkt Assy	1
G30006A	Bearing Housing Assembly	1	G40211	Bender Rail	1
G30007B	Crank Shaft	1	G40212	Driving Rail	1
G30048	Motor Mounting Plate	1	G40213	Head Mounting Block	1
G30053	Bearing 1/2x1/2	5	G40219	Screw M6x1.0x30	2
G30054	Bearing 5/8x3/4	1	G40220	Spring Clip Block	1
G30063	Shoulder Screw 5/8x1	1	G40231	Upper Gear Shaft	1
G30064	Shoulder Screw 3/4x1-1/4	1	G40235A	Bender Cam Plate Assembly	1
G30067	Bolt 3/8-16x1	4	G40236A	Driver Cam Plate Assembly	1
G30099B	Adjustment Crank Housing	1	G40237	Crank Pin	1
G30103	Adjuster Stop	1	G40238B	Crank Arm	1
G30117B	Motor Cover	1	G40239BA	Crank Housing Slide Plate Assembly	1

Part Number / Description Cross-Reference

PART NO.	DESCRIPTION	QUANTITY	PART NO.	DESCRIPTION	QUANTITY
G40240A	Crank Housing Assembly	1	G40656	Driver 5/8 - 20x24 Wire	1
G40242	Head Drive Shaft	1	G40657	Driver 5/8 - 19x21-1/2 Wire	1
G40262	Small Feed Gear Shaft	1	G40658	Driver 5/8 - 20 Wire	1
G40284	Lower Tension Pawl Spring	1	G40659	Driver 5/8 - 18x20 Wire	1
G40286A	Wire Guide Spring	1	G40672	Feed Slide Block	1
G40301	Drive Cam Gear	1	G40680	Pivot Block Insert-5/8" Cr.	1
G40302	Drive Gear	3	G40701	Wire Hold	1
G40402	Screw M5x0.8x16	3	G40702	Large Clincher Arm Spacer	1
G40500BA	Bonnet Plate Assembly - Left	1	G40703	Cam Follower Stud	1
G40501BA	Bonnet Plate Assembly - Right	1	G40704	Lower Bearing Block	1
G40510A	Large Feed Gear Assembly	1	G40705A	Vertical Drive Shaft Assembly	2
G40511A	Wire Feed Pinion Assembly	1	G40708	Bearing Mounting Plate	1
G40512	Small Feed Gear	1	G40709	Wire Holder Spring Block	1
G40513B	Supporter Guide Plate	2	G40710A	Feed Lever Spring Bracket Assembly	1
G40515	Dowel Pin M6x18	1	G40711B	Cutter Box Adjustment Link	1
G40520	Wire Spool Mounting Bracket	1	G40716A	Lower Wire Straightener Bracket	1
G40527B	Feed Rack	1	G40716AA	Lower Wire Straight Brkt, Complete	1
G40530	Feed Rack Block	1	G40750	Wire Hold Spring	1
G40531BA	Feed Slide Assembly	1	G40751	Dowel Pin M6x20	1
G40532A	Feed Lever Assembly	1	G40752	E-Ring - Heavy Duty	1
G40536	Feed Gear Bracket	1	G40753	Lock Collar	2
G40537	Feed Gear Clutch	1	G40754	Dowel Pin M8x20	2
G40547BA	Bender Bar Assembly	1	G40755	Clincher Pad Guide Shaft	2
G40551B	Driver Bar, M30	1	G40756	Spring Pin M4x24	1
G40557	Dowel Pin M6x50	1	G40757	Dowel Pin M10x28	1
G40562	Bender Slide Block	1	G40758	E-Ring 12mm	1
G40563	Cutter Operating Cam	1	G40759	Keyway - 8mm x 1/2	1
G40564A	Bender Slide Pin Block Assembly	1	G40760	Keyway - 6mm x 3/4	2
G40569	Bender Slide Pin	1	G40761	Keyway - 6mm x 1-1/2	3
G40571	Dowel Pin M6x12	1	G40763	Keyway - 8mm x 3/4	1
G40574	Feed Rack Adjustment Stud	1	G40764	E-Ring 1/2	3
G40581	Upper Wire Tube	1	G40765	Wire Straightener Roll Stud	4
G40597A	Cutter Block Assembly	1	G40766	Straightener Eccentric	3
G40598A	Cutter Operating Slide Assembly	1	G40767A	Upper Wire Straightener Brkt Asy	1
G40599A	Lower Wire Tube Assembly	1	G40767AA	Upper Wire Straight Brkt - Complete	1
G40600	Fixed Wire Cutter	1	G40768	Clevis Pin 1/2x2-1/4	1
G40601	Fixed Cutter Cover	1	G40769	Clevis Pin 1/2x2	2
G40603	Cutter Box Guide Plate	1	G40770	Hitch Pin	2
G40604	Upper Cutter Box Guide Plate	1	G40771	Dowel Pin M4X10	2
G40605	Lower Cutter Box Guide Plate	1	G40772	Adjuster Lock Lever	1
G40630BA	Cutter Operating Lever Assembly	1	G40773	Thumbscrew - Knurled	1
G40638	Feed Rack Cam	1	G40800	Shoulder Screw M10x25	1
G40642	Cutter Box Adjustment Slide	1	G40802	Screw M6x1.0x50	7
G40643BA	Wire Holder Pivot Block 5/8 Cr.	1	G40803	Screw M6x1.0x16	5
G40648	Bender Insert 5/8 - 20x24 & 23 Wire	2	G40804	Screw M8x1.25x16	29
G40649	Bender Insert 5/8 - 19x21-1/2 & 24 Wire	2	G40808	Screw M6x1.0x12 - Dog Point	2
G40650	Bender Insert 5/8 - 18x20 & 20 Wire	2	G40809	Screw M6x1.0x12 - Low Head	8
G40652	Driver 5/8 - 24 Wire	1	G40810	Shoulder Screw	1
G40653BA	Supporter Assembly 5/8	1	G40811	Screw M6x1.0x8 - Dog Point	1
G40654	Driver 5/8 - 23 Wire	1	G40812	Screw M8x1.25x16 - Low Head	1

Part Number / Description Cross-Reference

PART NO.	DESCRIPTION	QUANTITY	PART NO.	DESCRIPTION	QUANTITY
G40813	Shoulder Screw	2	KN1032	Kep Nut 10-32	3
G40814	Shoulder Screw	1	KN1420	Kep Nut 1/4	1
G40815	Screw M8x1.25x12	1	LW14	Lock Washer	4
G40816	Screw M8x1.25x25	2	LW38	Lock Washer	9
G40817	Shoulder Screw M12x20	12	M-TOOL KIT	Kit - M-Series Tool	1
G40818	Screw M6x1.0x25	2	M11009	Plastic Washer	1
G40820	Shoulder Screw M6x10	2	P2582	Connector 3/8x90 Degrees	3
G40821	Screw 1/2-13x1	1	P2731	Thumb Screw 1/4-20x3/4	1
G40823	Screw M6x1.0x16	4	P7507	Screw 1/4-20x3/4	8
G40824	Screw, NM8 x 1.25 x 8, Nylon	1	P7863	Retaining Ring	1
G40851	Lock Washer Ribbed M8	5	PG10219	Terminal 1/4x90 5/8	5
G40852	Spring Pin, M5 x 30	1	PG10255	Screw, 1/4-20 x 3/4", FHM	3
G40901	Feed Lever Pivot Bearing	1	PG10271	Washer 9/16	1
G40902	Upper Drive Shaft Bearing	2	PW10	Washer	2
G40903	Worm Shaft Bearing	2	PW10.3	Flat Washer 3/16	4
G40905	Clincher Cam Follower	1	PW12.1	Washer Black 1/2	1
G40906	Ball Bearing	1	PW12.4	Washer Black 1/2	4
G40907	Drive Shaft Coupling	1	PW14	Flat Washer	2-8
G40908	Crank Bushing	2	PW14.2	Washer Zinc	4
G40909	Head Drive Shaft Bearing	1	PW14.6	Washer 1/4	4
G40911A	U-Joint & Splined Shaft Assembly	1	PW38	Washer	8
G40912	Grooved Straightener Roller	2	SU-0308853	Screw 3/8X3/8	2
G40950AA	Clincher Pad Assembly	1	SW14.1	Lock Washer	3
G40952A	Clincher Back Plate Assembly	1	SW516.3	C'Sunk Lock Washer	2
G40954	Clincher Front Plate	1	UA1428.1	Set Screw 1/4-28X1/4	3
G40955F	Clincher Point - Flat	2	UA3216.2	Clincher Slide Block Screw	2
G40955R	Clincher Point - Round	2	UA3410.4	Screw, 10-32 x 5/8"	2
G40956A	Clincher Base Assembly	1	UA3806.2	Screw 10-32x3/8	2
G40957	Clincher Adjustment Shaft	1	UA3806.9	Screw 10-32x3/8	3
G40958	Clincher Adjustment Worm Gear	1	UA3808.2	Screw 10-32x1/2	2
G40959	Clincher Height Adjust Handle	1	UA3810.10	Shoulder Screw 1/4x5/8	2
G40960	Worm Shaft	1	UA4810.1	Screw 1/4-20x5/8	3
G40961	Clincher Adjusting Worm	1	UA4812.7	Screw 1/4-20x3/4	3
G40962	Table Pivot Shaft	1	UA4828.3	Set Screw - Cup Point	4
G40964A	Work Table Assembly	1	UA5112.1	Screw 5/16-18x3/4	1
G40973B	Work Guide Backtop	1	UA5116.1	Screw 5/16-18x1	6
G40975	Clincher Upright Extension	1	UA5120.2	Screw 5/16-18x1-1/4	2
G40976	Clincher Slide	1	UA51618.1	Screw, 5/16-18 x 7/8	4
G50125	Screw M5x0.8x20	3	UA5812.7	Screw 5/16-18x3/4	2
G50234	E-Ring 4mm	2	UA6112.1	Screw 3/8-16x3/4	4
G50266	Dowel M5x10	2	UA6116.1	Screw 3/8-16x1	4
G50396	Screw M5x.8x12	3	UA8164	Screw 1/2-13x4	1
HN1024	Nut 10-24	2			
HN1213.2	Hex Jam Nut 1/2-13	1			
HN1420.2	Hex Jam Nut 1/4-20	4			
HN3816	Hex Nut 3/8-16	5			
HN51618	Hex Nut 5/16-18	1			
HN51618.2	Hex Jam Nut 5/16-18	2			

Wiring Diagram

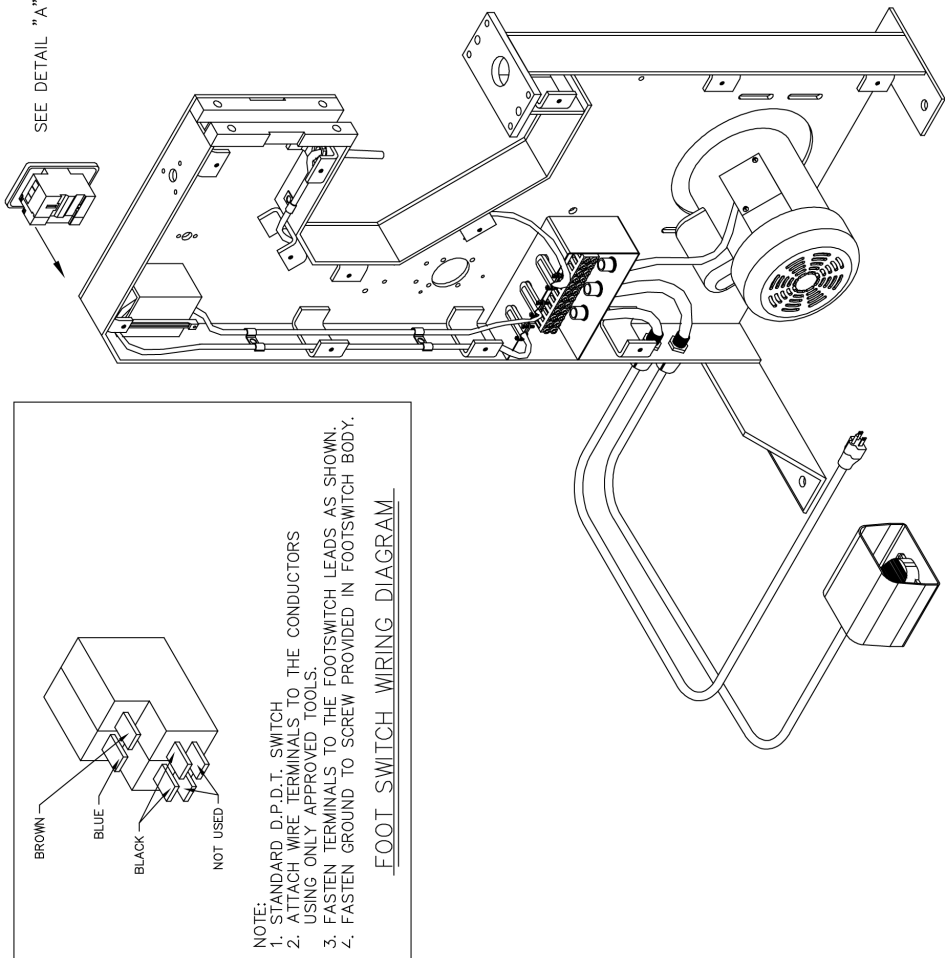
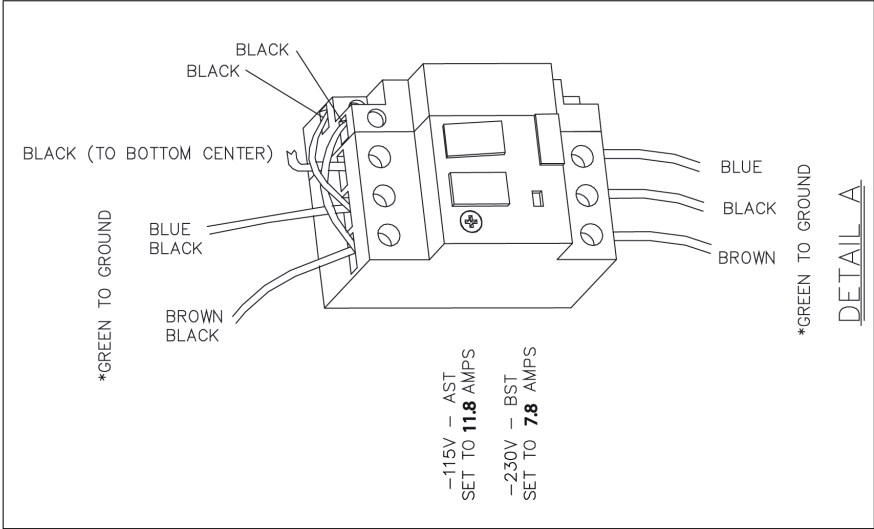

Complete Wiring with Detail

Wiring Diagram

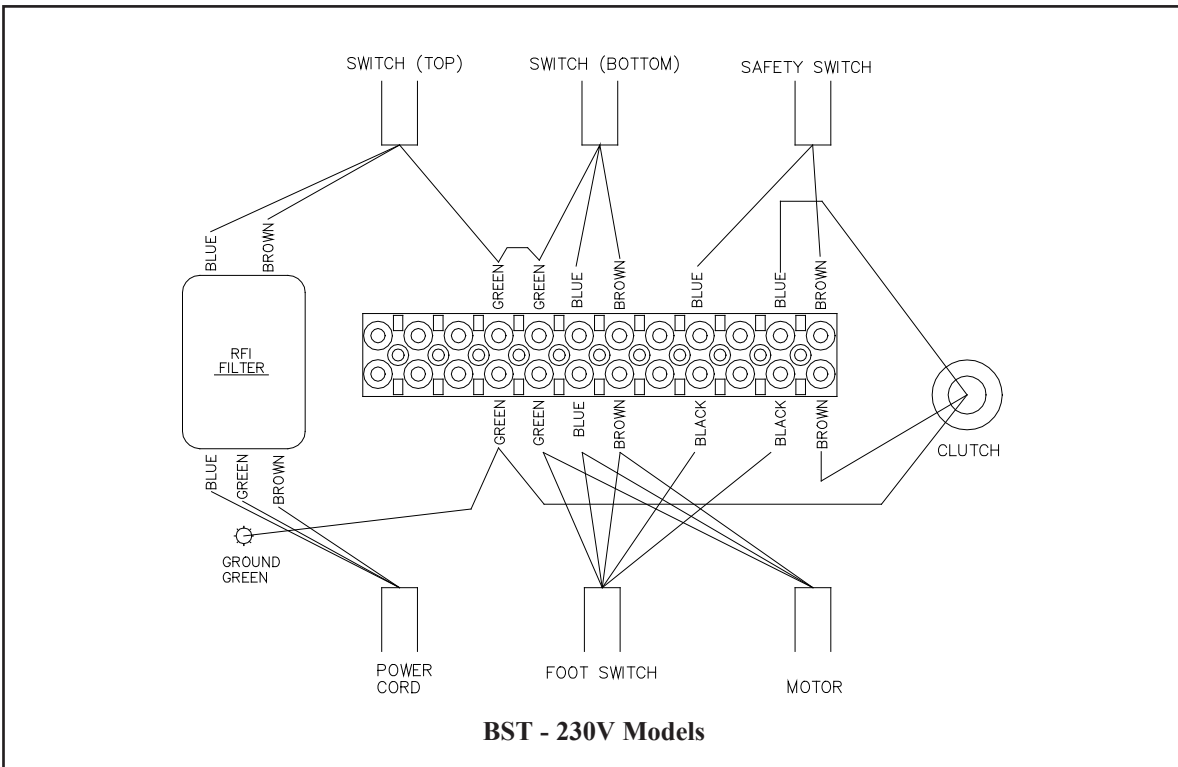
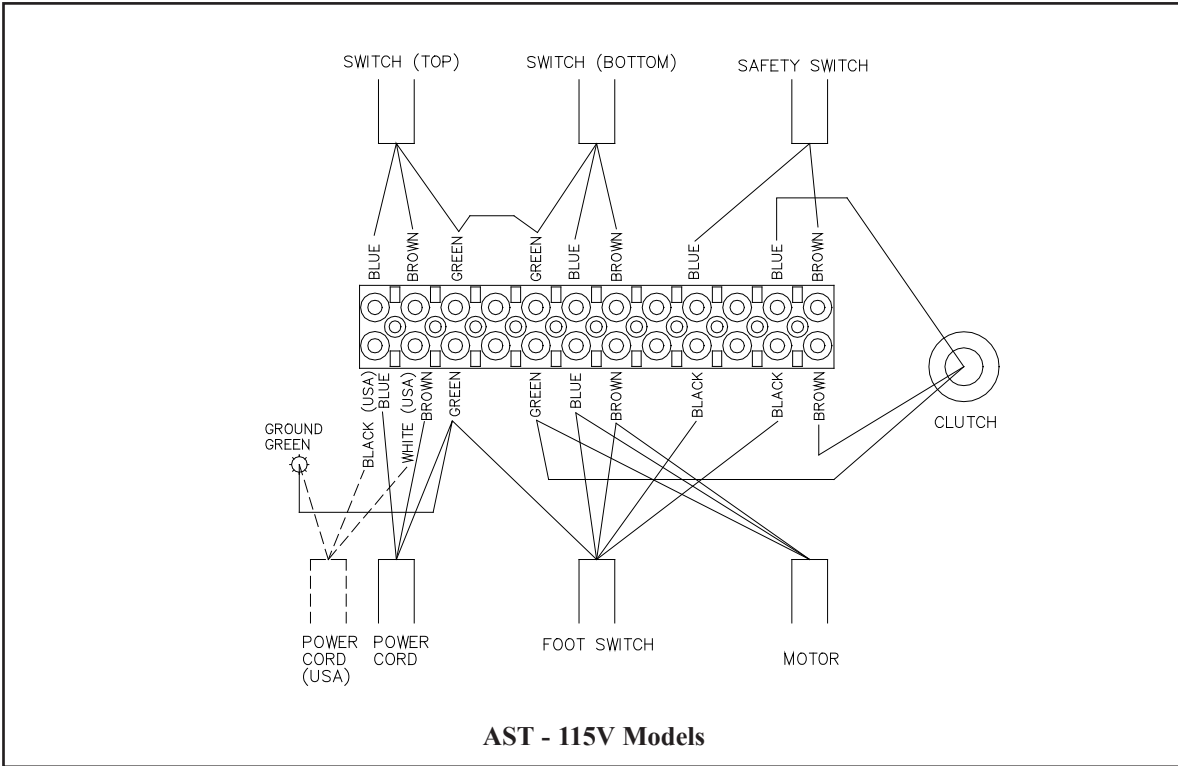

REGISTRATION

To better service your wire stitching needs, please take a moment to fill out and return this registration card.

Please take a moment to fill out the attached card and mail it to DeLuxe Stitcher Company, Inc. In addition, duplicate the information for your records to assist when making further inquiries.

CUSTOMER

Name : _____
(First) (Middle Initial) (Last)
Company : _____
Street Address : _____
City : _____ State/Province : _____ Zip : _____
Country : _____
Phone : _____ Fax : _____ E-mail : _____

PRODUCT

Machine(s) Purchased : _____
Serial Number(s) : _____
With Head(s) : _____
(Type/Quantity Purchased)
Serial Number(s) : _____
Head(s) Purchased : _____
Serial Number(s) : _____

DEALER

Date Received : _____
Dealer Name : _____
Dealer Street Address : _____
City : _____ State/Province : _____ Zip : _____
Country : _____
Dealer Phone : _____

Other Bindery Products Used : _____

PRODUCT

Machine(s) Purchased : _____
Serial Number(s) : _____
With Head(s) : _____
(Type/Quantity Purchased)
Serial Number(s) : _____
Head(s) Purchased : _____
Serial Number(s) : _____

DELUXE STITCHER GRAPHIC ARTS REPRESENTATIVE

Date Received : _____
Dealer Name : _____
Dealer Street Address : _____
City : _____ State/Province : _____ Zip : _____
Country : _____
Dealer Phone : _____

Would you like information sent to you about new products that would benefit your company? Yes No

Common Replacement Parts

Below is a list of the most common wear/replacement parts for the M30 Stitcher. This guide should help you when ordering replacement parts. If the part you need is not listed below, please refer to the more detailed parts list in this manual.

Description	Item Number
Screw, M4x0.7x10	G20167
Moving Cutter	G40145
Fixed Wire Cutter	G40600
Driver, 5/8", 19x21-1/2 Wire	G40657
Clincher Point - Flat	G40955F
Clincher Point - Round	G40955R
Clincher Slide	G40976

PLACE
STAMP
HERE

DELUXE STITCHER
COMPANY, INC.
 3747 N Acorn Ln
 Franklin Park, Illinois 60131 U.S.A.
 Attn: Customer Service

LIMITED WARRANTY

DeLuxe Stitcher Company, Inc. warrants to the original retail purchaser that this product is free from defects in material and workmanship and agrees to repair or replace, at DeLuxe Stitcher's option, any defective product within 90 days from the date of purchase. This warranty is not transferable. It covers damage resulting only from defects in material or workmanship and does not cover conditions or malfunctions resulting from normal wear, neglect, abuse or accident.

This warranty is in lieu of all other express warranties. Any warranty of merchantability or fitness for a particular purpose is limited to the duration of this warranty. DeLuxe Stitcher shall not be liable for any incidental or consequential damages.

Some states do not allow limitations on how long an implied warranty lasts, or the exclusion or limitation of incidental or consequential damages, so the above limitations or exclusions may not apply to you. This warranty gives you specific legal rights and you may also have other rights which vary from state to state.

To obtain warranty service you must return the product, at your expense, together with proof of purchase to an authorized DeLuxe Stitcher Company Graphic Arts Dealer.

Always use genuine DeLuxe Stitcher parts. When ordering parts, please identify the part number, the part name, the wire size and crown size of your Stitcher.

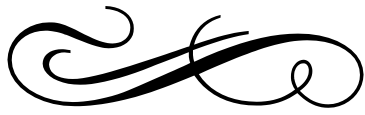

Declaration of Conformity

We, *DeLuxe Stitcher Company*

3747 Acorn Lane

Franklin Park, Illinois 60131 U.S.A

Telephone 847-455-4400

Facsimile 847-455-4900

hereby declare under our sole responsibility that the

M30-BST Stitching / Stapling Machines

to which this declaration relates is in conformity with the following European product safety directives:

Machinery Safety Directive

(89/392/EEC and amendments

91/368/EEC, 93/44/EEC, 93/68/EEC)

Electromagnetic Compatibility Directive

(89/336/EEC and amendments

91/C162/08, 92/31/EEC, 93/68/EEC)

as is verified by compliance with the following standards:

EN 60204-1:1992 prEN 894-1:1992 prEN 953:1992

EN 294:1992 prEN 894-3:1992 EN 55014:1193

prEN 614-1:1991 prEN 1050:1993 EN 55104:1995

Executed for DeLuxe Stitcher Company

this first *day of* January *in the year* 2009

By Frank P. Cangelosi Signature Frank P. Cangelosi

Title President





3747 Acorn Lane • Franklin Park • Illinois 60131
Phone: 847-455-4400 • 800-634-0810
Fax: 847-455-4900 • 800-417-9251
<http://www.deluxestitcher.com>

DBSM30 10-23